

WIRING DIAGRAM

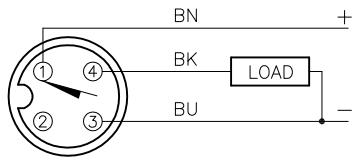

OUTPUT: AP6X

SHORT-CIRCUIT AND OVERLOAD PROTECTED

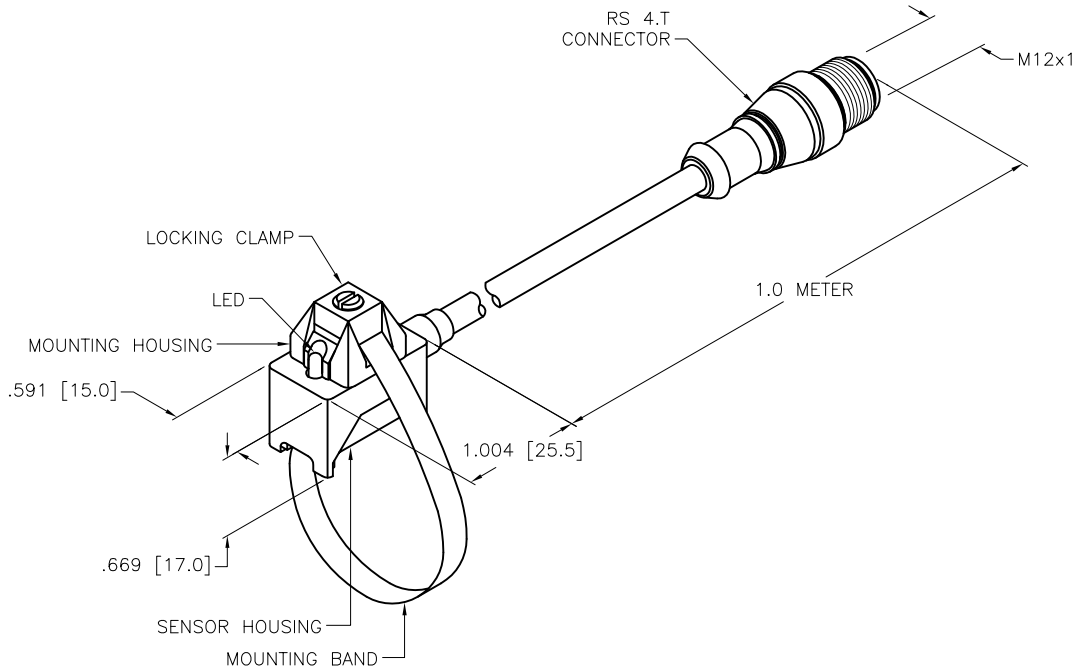

SPECIFICATIONS

OPERATING VOLTAGE	10-30 VDC (SHORT-CIRCUIT PROTECTED)
RIPPLE	≤ 10%
HYSTERESIS	≤ 1 mm
MAX. VOLTAGE DROP	≤ 2.3 V at 200 mA
OUTPUT FUNCTION	NORMALLY OPEN 3-WIRE DC SELF-CONTAINED
TTL COMPATIBLE	NO
SHORT-CIRCUIT PROTECTED	YES
TRIGGER CURRENT FOR OVERLOAD PROTECTION	≥ 220 mA
CONTINUOUS LOAD CURRENT	≤ 200 mA
RESIDUAL CURRENT	< 10µ A
NO-LOAD CURRENT	≤ 2.0 mA
TIME DELAY BEFORE AVAILABILITY	≤ 5 ms
POWER-ON EFFECT PROTECTION	INCORPORATED
REVERSE POLARITY PROTECTION	INCORPORATED
WIRE-BREAK PROTECTION	INCORPORATED
OPERATING TEMPERATURE	-25°C to +70°C (-13°F to +158°F)
ENCLOSURE	MEETS NEMA 1, 3, 4, 6, 13 AND IEC IP67
SHOCK	30 g, 11 ms
VIBRATION	55 Hz, 1 mm AMPLITUDE (IN ALL 3 PLANES)
LED FUNCTION	RED: OUTPUT ENERGIZED
SWITCHING FREQUENCY	1000 Hz
REPEATABILITY	≤ 0.1 mm (CONSTANT TEMPERATURE AND VOLTAGE)
TEMPERATURE DRIFT	≤ 0.1 mm
MAXIMUM APPROACH VELOCITY	10 m/second
MAGNETIC ACTUATION STRENGTH	20-350 GAUSS (2-35 mT)

NOTES:

1. FOR CYLINDERS WITH DIAMETERS UP TO 25 mm USE MOUNTING BAND KST-SB170; FOR DIAMETERS TO 80 mm USE KST-SB335.

2. PART	MATERIAL
SENSOR HOUSING	[PA 12-GF30]
MOUNTING HOUSING	[DIE-CAST ZINC]
LOCKING CLAMP	[DIE-CAST ZINC]
MOUNTING BAND	[STAINLESS STEEL]

SOURCE DRAWING - FOR REFERENCE ONLY

RELATED DOCUMENTS 1. 2. 3. 4.	3RD ANGLE PROJECTION 	THIS DRAWING IS CONFIDENTIAL AND THE PROPERTY OF TURCK INC. USE OF THIS DOCUMENT WITHOUT WRITTEN PERMISSION IS PROHIBITED.		TURCK INC High Technology Sensors and Automation Controls 3000 CAMPUS DRIVE MINNEAPOLIS, MN 55441 1-800-544-7769 (763) 553-7300 (763) 553-0708 fax turck.com	
	MATERIAL SEE NOTE 2	DRFT RDS	DATE 03/26/12	DESCRIPTION BIM-KST-AP6X-1M-RS 4T W/CLAMP	
FINISH	ALL DIMENSIONS DISPLAYED ON THIS DRAWING ARE FOR REFERENCE ONLY	APVD J.M.	SCALE 1=1.3	IDENTIFICATION NO. M4674092	
CONTACT TURCK FOR MORE INFORMATION		UNIT OF MEASUREMENT INCH [MILLIMETER]		REV A	
DO NOT SCALE THIS DRAWING		FILE: M4674092		SHEET 1 OF 1	

A	DRAWING RELEASE	RDS	03/26/12	
REV	DESCRIPTION	BY	DATE	ECO NO.