

BOS Q08M-PO-LE20-02 BOS0195

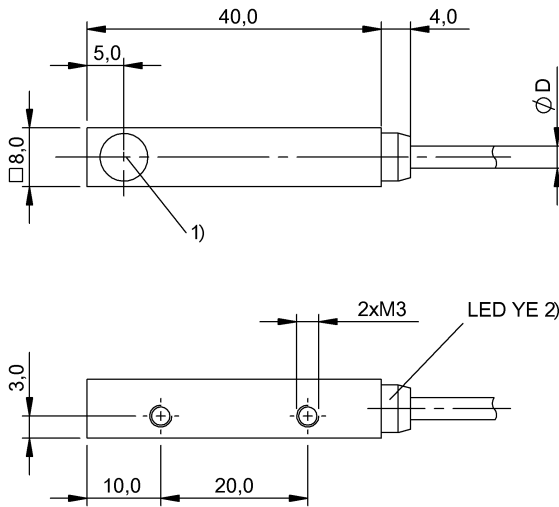

1) Optical axis 2) Light reception



Display/Operation

Adjuster no

Electrical connection

Cable diameter D 3.00 mm
 Cable length 2 m
 Conductor cross-section 0.14 mm²
 Connection type Cable, 2.00 m, PUR
 Number of conductors 3
 Polarity reversal protected yes
 Short-circuit protection yes

Electrical data

Load capacitance max. at U_e 0.1 µF
 No-load current I_o max. at U_e 10 mA
 Operating voltage U_b 10...30 VDC
 Rated insulation voltage U_i 75 V DC
 Rated operating current I_e DC 100 mA
 Rated operating voltage U_e DC 24 V
 Ready delay t_v max. 150 ms
 Reference emitter BOS Q08M-X-LS20-..
 Switching frequency 400 Hz
 Utilization category DC-13
 Voltage drop U_d max. at I_e 2.5 V

Environmental conditions

Ambient temperature 0...50 °C
 Protection type IEC 60529 IP67

General data

Approval/Conformity CE
 cULus
 Basic standard IEC 60947-5-2
 Series Q08M
 Style Square
 Connection 90°

Material

Housing material Zinc, Die casting
 Material jacket PUR
 Material sensing surface PMMA
 Surface protection nickel plates

Mechanical data

Dimension 8 x 44 x 8 mm
 Fastening detail Screw M3
 Smallest part typ. 0.28 mm at 1 m. R0 = 3.0 m

Optical data

Ambient light max. 5000 Lux
 Light type Laser Red light
 Principle of optical operation Through-beam sensor (receiver)

Output/Interface

Switching output PNP Normally closed (NC)

BOS Q08M-PO-LE20-02 BOS0195

Range/Distance

Measuring range	0...3 m
Range	0...3 m
Rated operating distance S_n	3 m
Ripple max. (% of U_e)	15 %

Remarks

The sensor is functional again after the overload has been eliminated.
 For surge resistance IVW and BURST we recommend an external protection circuit (see also "Instruction for Protection Circuit" drawing no. 825345)
 For line-transmitted disturbances an external protection circuit is recommended, e.g. capacitors ($\geq 20\text{nF}$) to ground, (see also Instruction for Protection Circuit Doc.-No.: 864234).
 Order accessories separately.
 Only for applications per NFPA 79 (machines with a supply voltage of maximum 600 V). Use an R/C (CYJV2) cable with suitable properties for attaching the device.

Wiring Diagram

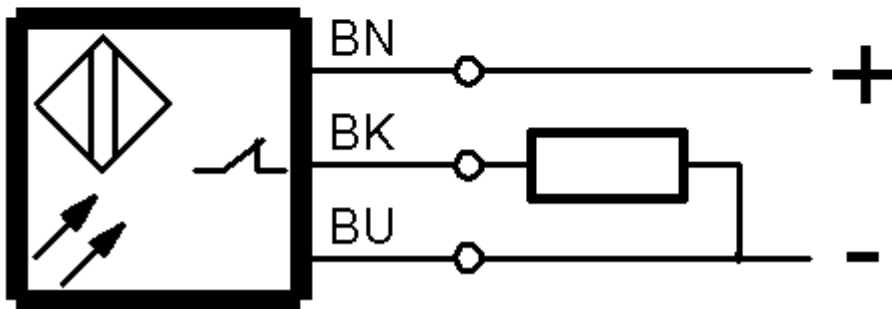

Symbols for Optoelectronic Sensors

