

SMD Choke Coils

Series: **G**
 Type: **ELLPFG**



Type ELLPFG

■ Features

- Magnetic shielded structure
- Low DC resistance and large current capability
- Shock resistant

RoHS compliant

■ Recommended Applications

- DC-DC converter circuitry for computer peripherals and cellular phones.
- Chopper circuit decoupling chokes for DC-DC converter circuitry.

■ Standard Packing Quantity

- 2000 pcs./Reel

■ Soldering Conditions

Please see Page 169

■ Safety Precautions

Please see Page 170

■ Explanation of Part Numbers

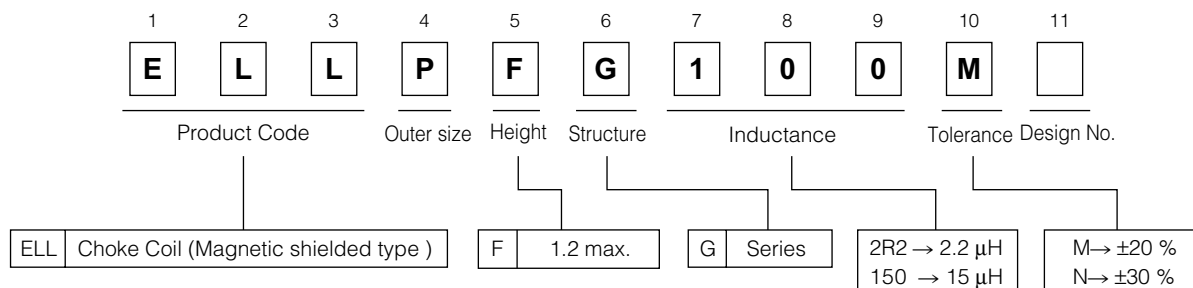

■ Dimensions in mm (not to scale)

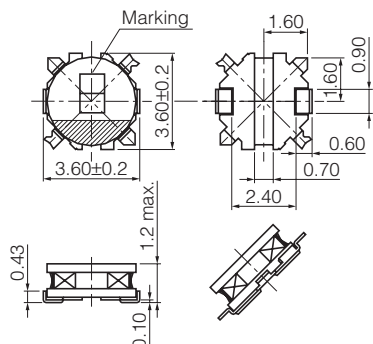

■ Recommended land patterns in mm (not to scale)

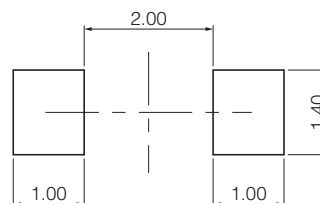

Standard Parts

Part Number	Inductance (100 kHz)		R _{DC} (at 20 °C)		Saturation Rated Current* ¹ (mA max.)	Temperature Rise Current* ² (mA max.)	Marking
	(μH)	Tol.	(mΩ)	Tol.			
ELLPFG1R0M	1.0	±20%	47	±20%	1700	1800	A
ELLPFG1R5M	1.5		57		1500	1600	C
ELLPFG2R2M	2.2		95		1200	1300	D
ELLPFG3R3M	3.3		130		1100	1100	E
ELLPFG4R7M	4.7		200		950	880	H
ELLPFG6R8M	6.8		240		740	800	K
ELLPFG8R2M	8.2		330		650	680	L
ELLPFG100M	10.0		370		600	650	M
ELLPFG120M	12.0		490		550	600	N
ELLPFG150M	15.0		600		520	540	O
ELLPFG220M	22.0		890		400	420	R
ELLPFG270M	27.0		980		380	400	S
ELLPFG330M	33.0		1200		360	370	T
ELLPFG470M	47.0		1800		280	300	V
ELLPFG680M	68.0		2500		240	260	X

*1 Saturation Rated Current : This DC current which causes a 30% inductance reduction from its nominal value.

*2 Temperature Rise Current : This indicates the value of current when temperature rise dt/t= 40 °C (at 20 °C).

Embossed Carrier Tape Dimensions in mm (not to scale)

