

**M****4AV SERIES  
CHART 4****MECHANICAL CHARACTERISTICS**

SUPPLY VOLTAGE	OPERATING TEMPERATURE °C	LEFT		RIGHT		DIFFERENTIAL LEFT OP TO R REL RIGHT OP TO L REL
		OPERATE	RELEASE	OPERATE	RELEASE	
4.5 TO 24.0/5	25°C	±.006	±.006	±.006	±.006	±.010
12.0	25°C	.213±.025	.237±.025	.337±.025	.313±.025	.10 ±.01
4.5 TO 24.0/5	-40°C TO +85°C	±.024	±.018	±.024	±.018	
4.5 TO 24.0/5	-40°C TO +125°C	±.040	±.030	±.040	±.030	±.070

**ELECTRICAL CHARACTERISTICS (OPERATING CONDITION)**

SUPPLY VOLTAGE	V <sub>cc</sub>	4.5 TO 26.5 Vdc
SUPPLY CURRENT "ON"	I <sub>cc</sub>	5 TO 18.5 mA
OUTPUT VOLTAGE "ON"	V <sub>sat</sub>	0 TO 0.4 Vdc (SINKING 20 mA)
OUTPUT VOLTAGE "ON"	V <sub>sat</sub>	0 TO 0.5 Vdc (SINKING 40mA)
OUTPUT CURRENT "OFF"	I <sub>leak</sub>	0 TO 10μA (PULLED UP TO 24 Vdc MAX)
OUTPUT SWITCHING RISE TIME	t <sub>r</sub>	0 TO 1.5μS (V <sub>cc</sub> 12V, R <sub>load</sub> 1K OHM, C <sub>load</sub> 20pF MAX 25°C)
OUTPUT SWITCHING FALL TIME	t <sub>f</sub>	0 TO 1.0μS (V <sub>cc</sub> 12V, R <sub>load</sub> 1K OHM, C <sub>load</sub> 20pF MAX 25°C)
REVERSE SUPPLY VOLTAGE CURRENT	I <sub>ccr</sub>	-2.5 TO 0 mA (-30 VOLT SUPPLY, 0 VOLT OUTPUT APPLIED)

**ABSOLUTE MAXIMUM RATINGS**

SUPPLY VOLTAGE	±30 VDC
VOLTAGE APPLIED TO OUTPUT	-0.5VDC TO +30VDC
OUTPUT CURRENT	±50mA
TEMPERATURE	-40°C TO +150°C
TRANSIENT SUPPLY CURRENT	±0.5 AMP 15μS MAX
TRANSIENT OUTPUT CURRENT	±0.5 AMP 15μS MAX

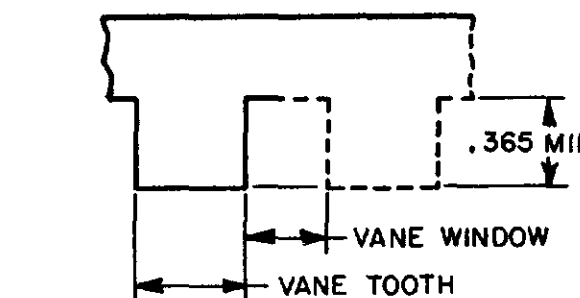
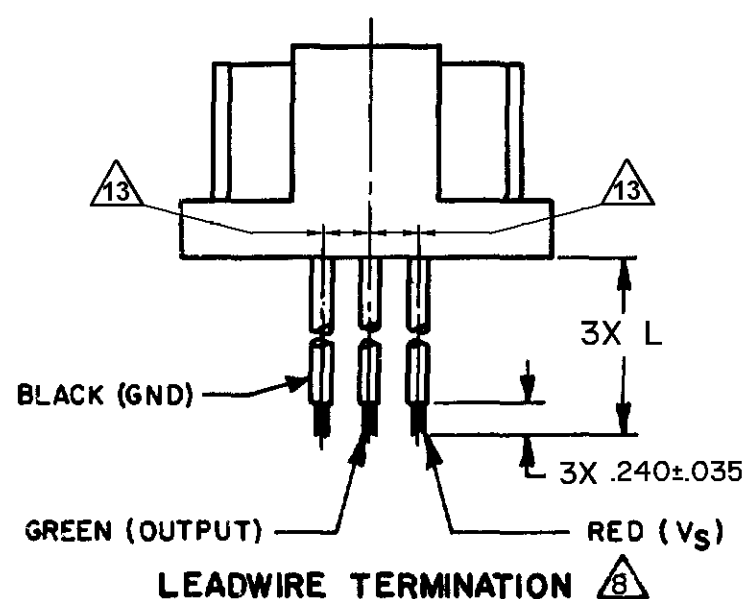
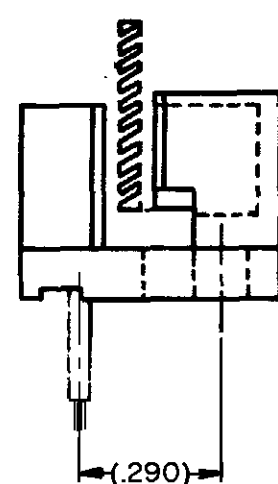
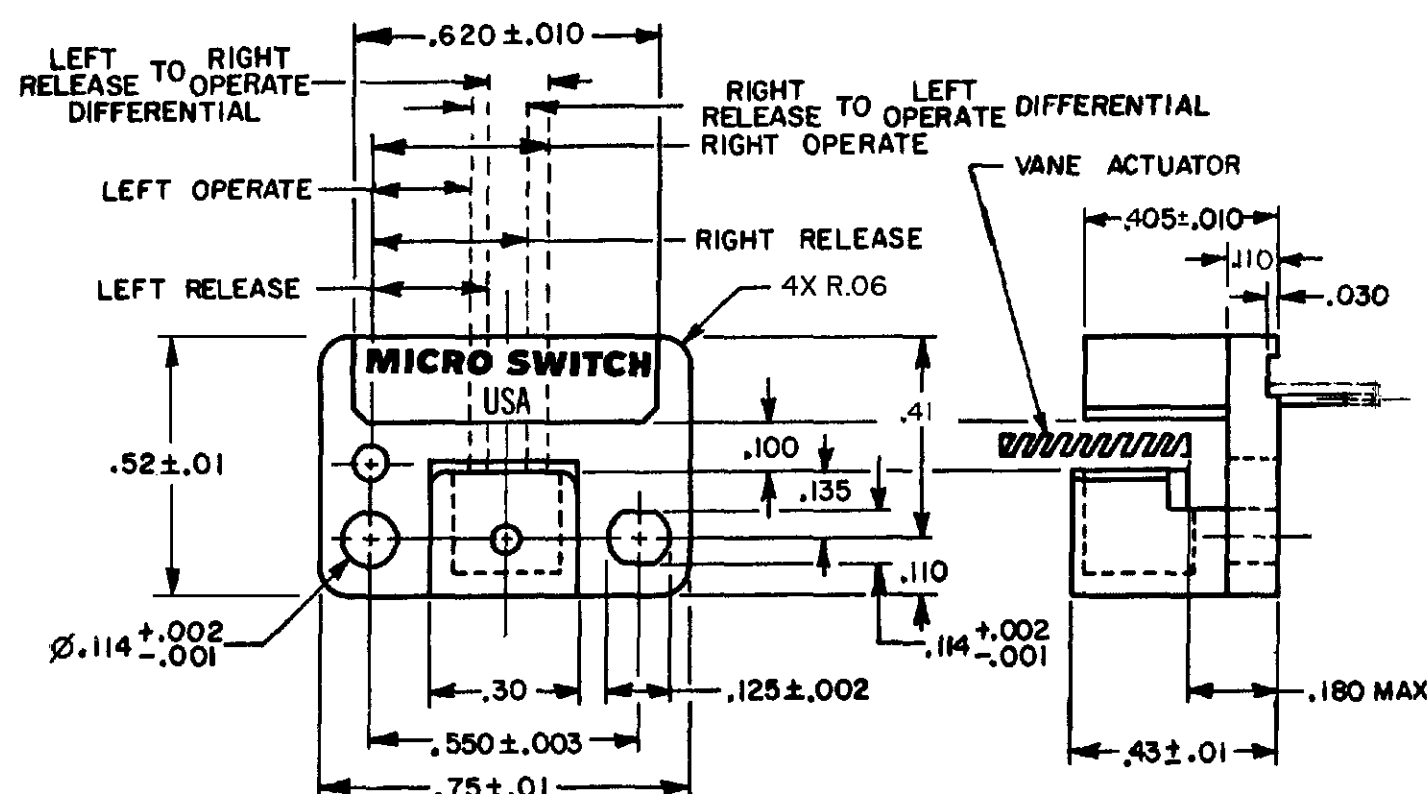

ACTUATOR THICKNESS	MINIMUM WINDOW	MINIMUM TOOTH
.040	.400	.400
.062	.400	.250

**VANE ACTUATOR**

(MATERIAL TO BE ANNEALED 1010-1018 COLD ROLLED STEEL OR LOWER IN CARBON)

CATALOG LISTING	OUTPUT STYLE	TERMINAL STYLE	DIM. L
4AV15F	SINGLE	LEADWIRE	5.50±.25
4AV16F	SINGLE	LEADWIRE	7.45±.25
4AV17F	SINGLE	LEADWIRE	13.15±.50
4AV18F	SINGLE	LEADWIRE	18.15±.50
4AV19F	SINGLE	LEADWIRE	22.0±.5
4AV20F-T1	AMP	TERMINAL	11
4AV20F-T2	MOLEX	TERMINAL	9

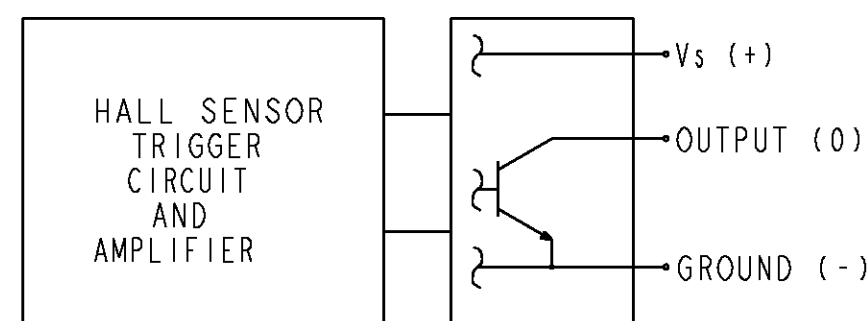
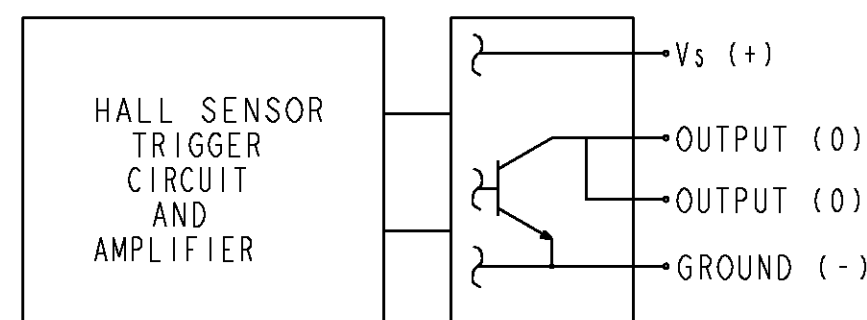
**SINGLE OUTPUT****DOUBLE OUTPUT**

BLOCK DIAGRAM SHOWING CURRENT SINKING OUTPUT

TRANSIENT CHARACTERISTICS (REFERENCE ISO 7637-1, 25°C)			
INDUCTIVE LOAD OPENING	PULSE 1	DURATION <0.2mS	-110 VOLTS
INDUCTIVE LOAD OPENING	PULSE 1	DURATION <2mS	-100 VOLTS
SERIES CURRENT INTERRUPT	PULSE 2	DURATION <200mS	+150 VOLTS
LOAD DUMP	PULSE 5	DURATION <400mS	+120 VOLTS
FIELD DECAY	PULSE 36	DURATION <100nS	+200 VOLTS
NEGATIVE TRANSIENT	PULSE 39	DURATION <100nS	-200 VOLTS
RFI	1 MHz THROUGH 1000 MHz		> 40 V/M

**NOTES**

- ELECTRICAL CHARACTERISTICS SPECIFIED OVER VOLTAGE AND TEMPERATURE RANGE USING AN ACTUATOR .040 THICK WITH A .400 TOOTH AND WINDOW PASSING THROUGH THE CENTER OF THE AIR GAP
- SWITCH IS OFF (RELEASE CONDITION) WHEN VANE ACTUATOR TOOTH IS IN THE AIR GAP
- THE OUTPUT CURRENT MAXIMUM IS TOTAL OF OUTPUT SINKING CURRENTS
- ABSOLUTE MAXIMUM RATINGS ARE THE EXTREME LIMITS THAT THE DEVICE WILL WITHSTAND WITHOUT DAMAGE. HOWEVER, THE ELECTRICAL AND MECHANICAL CHARACTERISTICS ARE NOT GUARANTEED ABOVE THE RECOMMENDED OPERATING CONDITIONS NOR WILL THE DEVICE NECESSARILY FUNCTION. RATINGS ARE TO BE CONSIDERED INDIVIDUALLY, NOT COMBINED
- MAXIMUM CHANGE IN VANE TRAVEL MECHANICAL CHARACTERISTICS SWITCHING POINT REFERENCING 25°C AND 12Vdc INITIAL CONDITION
- PRODUCT PERFORMANCE EVALUATED PER TS 060 192
- WHEN HAND SOLDERING PRINTED CIRCUIT, BOARD TERMINATIONS, USE A Ø.125 THERMISTATICALLY CONTROLLED TIP OF 550°F AND APPLY TO THE TERMINALS NO LONGER THAN 6 SECONDS
- LEADWIRES ARE 24 AWG WITH CROSSLINK POLYETHYLENE INSULATION OF Ø.060 MAX O.D.
- MOLEX TERMINAL 22-05-3041 LOCKING FEATURE ON T2 LISTINGS MATE WITH MOLEX HOUSING 2695/6471
- WILL MATE WITH AMP HOUSING NO.87499-B ON T1 LISTINGS ONLY
- AMP TERMINALS 103323-4
- LISTINGS 4AV20F-T1 AND 4AV20F-T2 HAVE A MAXIMUM TEMPERATURE RATING OF 85°C DUE TO TERMINAL BLOCK LIMITATIONS
- CENTER TO CENTER LEAD WIRE SPACING TO BE 7MM ±1MM WHERE WIRES EXIT SENSOR BODY

ANSI Y14.5M 1982 APPLIES  
MASTER REDUCED

**MICRO SWITCH**  
a Honeywell Division  
FED. MFG. CODE 91929

**SOLID STATE  
VANE SWITCH**

CATALOG LISTING  
**4AV SERIES  
CHART 4**

THIRD ANGLE PROJECTION		
SCALE	3:1	
DO NOT SCALE PRINT		
UNLESS OTHERWISE SPECIFIED TOLERANCES ARE		
ONE PLACE	(.0)	±.030
TWO PLACES	(.00)	±.015
THREE PLACES	(.000)	±.005
ANGLES		±
WEIGHT		

DRAWING NUMBER  
**4AV SERIES CHART 4**  
PAGE 1 OF 2

ISSUE  
**7**

REVISIONS  
A CO-93446  
8 J W  
22 SEP 98  
B PR-23514  
DL  
26 OCT 98  
C CO93789  
DL  
19 FEB 99  
D 94108-A  
0024823  
21 SEP 06  
E  
0030666  
TSK  
21 MAY 07

FORMTEK  
DRAWN  
J J A  
11 MAY 98  
CHECK  
J A F  
11 MAY 98  
CHECK  
L G  
21 SEP 06  
CHECK  
C M H  
21 MAY 07  
RELEASE NO.  
DR-5009  
REPLACES  
X102209-AV

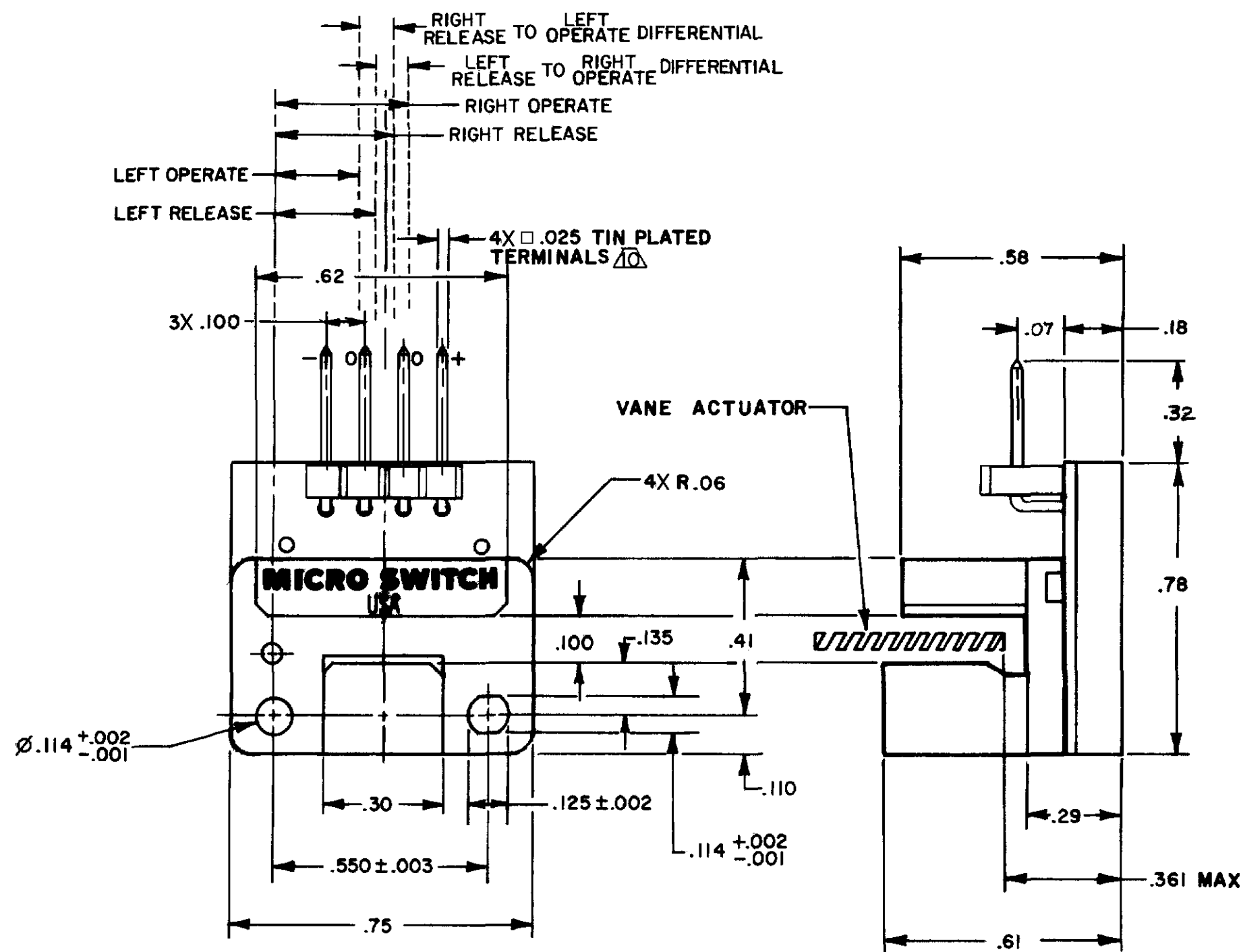
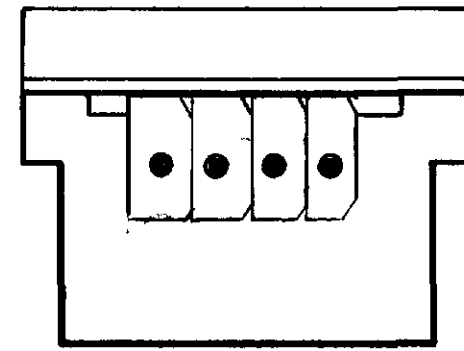
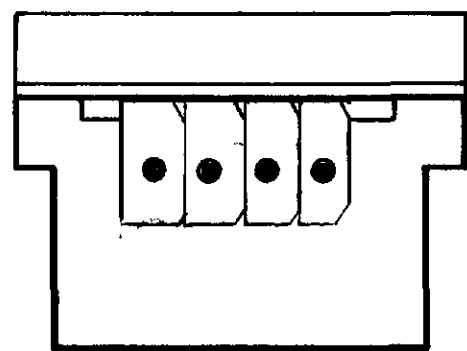

STYLE T1

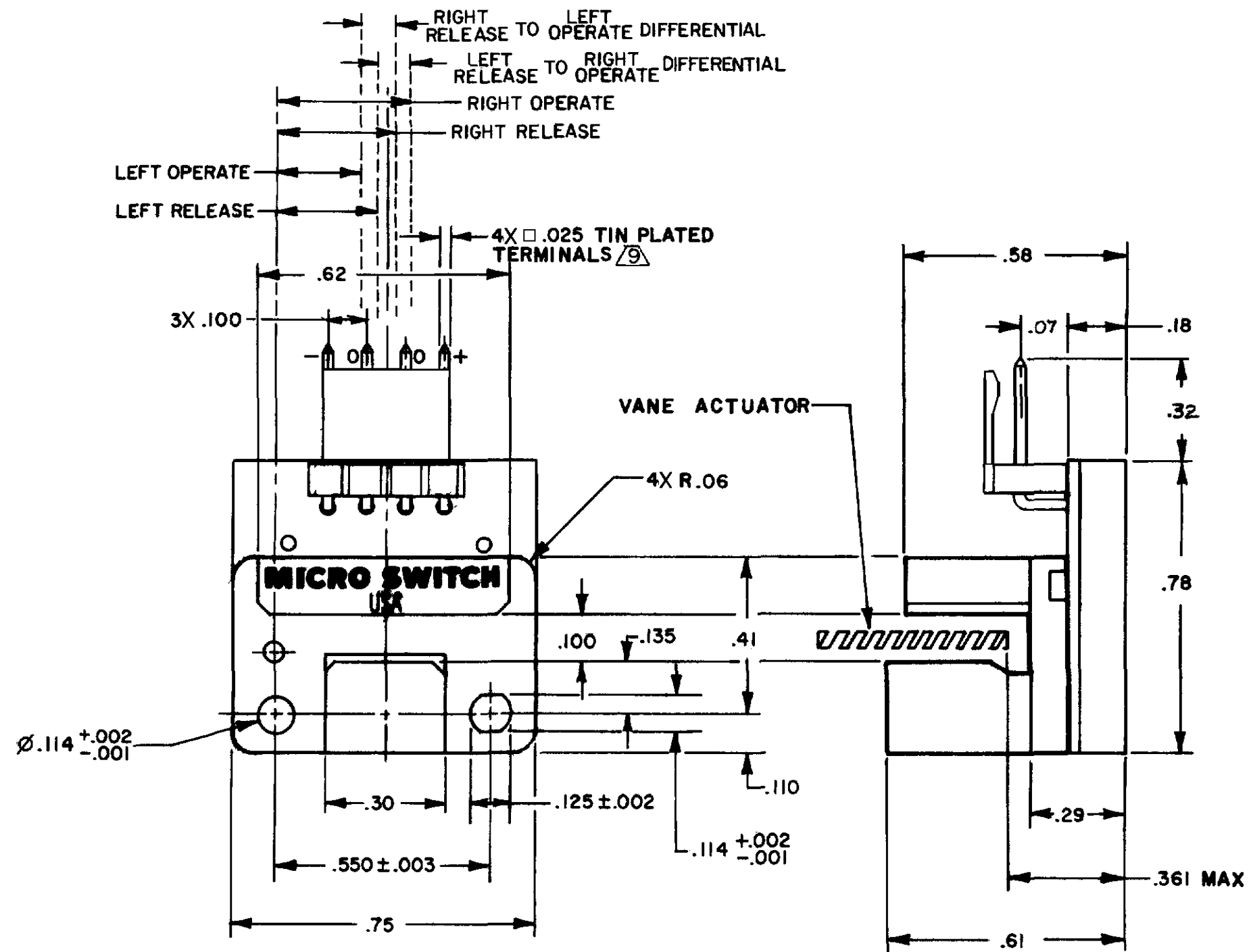

STYLE T2

DRAWING NUMBER: 4AV SERIES CHART 4  
 PAGE 2 OF 2  
 ISSUE: 7  
 CHECK: CMH  
 DATE: 21MAY07  
 RELEASE NO.: DR-5009  
 REPLACES: X102209-AV  
 REVISIONS:  
 A PR-23514 DLT 2 OCT 98  
 B C093789 DLT 26 OCT 98  
 C 94108-A DLT 19 FEB 99  
 E 0024823 MFP 21 SEP 05  
 F 0030656 TSK 21MAY07  
 DRAWN: JJA  
 CHECK: JAF  
 DATE: 11 MAY 98

ANSI Y14.5M 1982 APPLIES  
 MASTER REDUCED

THIS DRAWING COVERS A PROPRIETARY ITEM AND IS THE PROPERTY OF MICRO SWITCH, A DIVISION OF HONEYWELL. THIS DRAWING IS NOT TO BE COPIED OR USED WITHOUT THE APPROVAL OF MICRO SWITCH.		THIRD ANGLE PROJECTION 	
<b>MICRO SWITCH</b> a Honeywell Division		SOLID STATE VANE SWITCH	
FEDERAL MFG. CODE 91929		CATALOG LISTING <b>4AV SERIES</b> <b>CHART 4</b>	
UNLESS OTHERWISE SPECIFIED TOLERANCES ARE		ONE PLACE (.0) ±.030 TWO PLACES (.00) ±.015 THREE PLACES (.000) ±.005 ANGLES ±	
WEIGHT		SCALE 3:1 DO NOT SCALE PRINT	