

Process Valve

Series VNA

2 Port Valve For Compressed Air and Air-hydro Circuit Control

Exclusively for air pressure system and air-hydro circuit control
Universal 2 Port Valve

Cylinder actuation by external pilot air

The balance poppet permits normal and reverse flow.

Operation from 0 MPa is possible.

Wide variations

N.C., N.O., C.O., types are available. Threaded type from 6A to 50A is standardized.

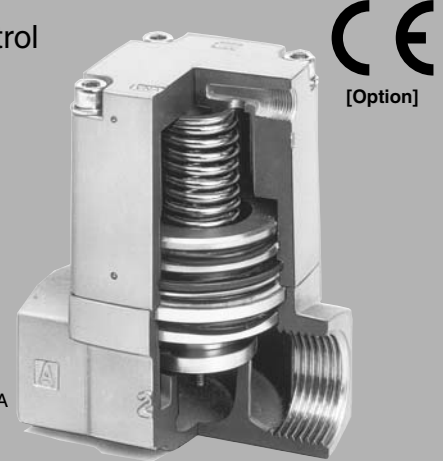

Compressed Air Air pressure circuit: Application examples

Actuator stop valve
Intermediate stop, inching

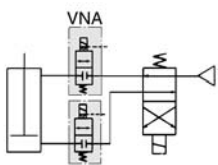

Actuator skip valve
Terminal deceleration, intermediate deceleration, accelerative start

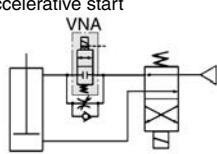

Actuator exhaust valve
High speed operation, high speed exhaust

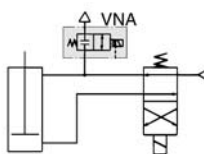

Air motor driving valve

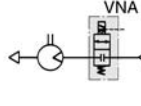

Air blow valve

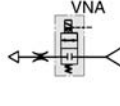

Line stop valve

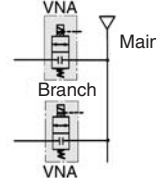

Residual line pressure exhaust valve

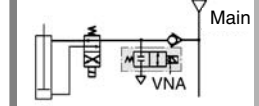

Air-hydro Air pressure circuit: Application examples

Operation Capacity When Used in Air-hydro Units

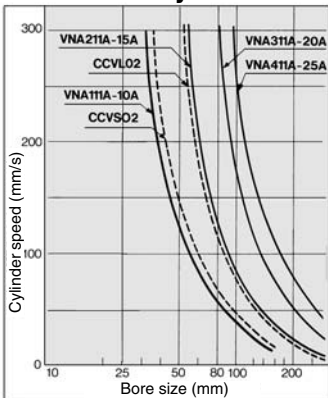

This series can supplement the capacity of conventional air-hydro valve units. They are suited to operate large bore cylinders as well as to simultaneously operate multiple cylinders and suspend their operation. Thus they can be used in the same way as the conventional air-hydro units.

Air-hydro circuit: Application example Basic circuit

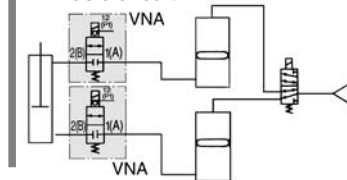

Conditions

Supply pressure	0.49 MPa
Hydraulic fluid	ISO VG32
Load	No load
Piping length	1 m
Piping diameter	VNA111A, CCVSD2: 3/8B (9 mm) VNA211A, CCVLO2: 1/2B (13 mm) VNA311A: 3/4B (19 mm) VNA411A: 1B (25 mm)



Refer to Air-hydro Unit pages in "Best Pneumatics No. 2" for further information on air-hydro.

Caution

When speed controller is mounted

Connect a speed controller (Series AS etc.) to A port of VNA□11 (in order to protect the speed control valve from surges when cylinder operation is suspended, thus improving stopping accuracy).

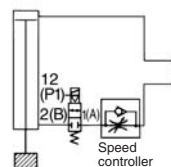
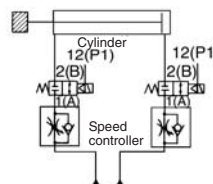

Caution

Skip valve function

Combination of 2 or more valves of Series VNA provides a skip valve function. Connect the skip valve to the A port side of a stop valve.

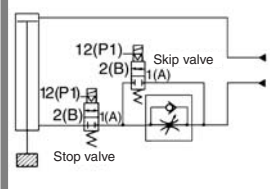
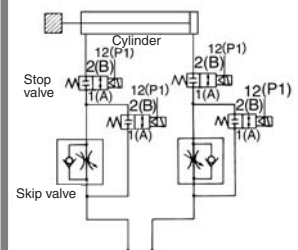

VNA

VNB

SGC

VNC

VNH

VND

VCC

Process Valve: 2 Port Valve For Compressed Air and Air-hydro Circuit Control

Series VNA



[Option]
Note) CE compliant: For D or DZ only

How to Order

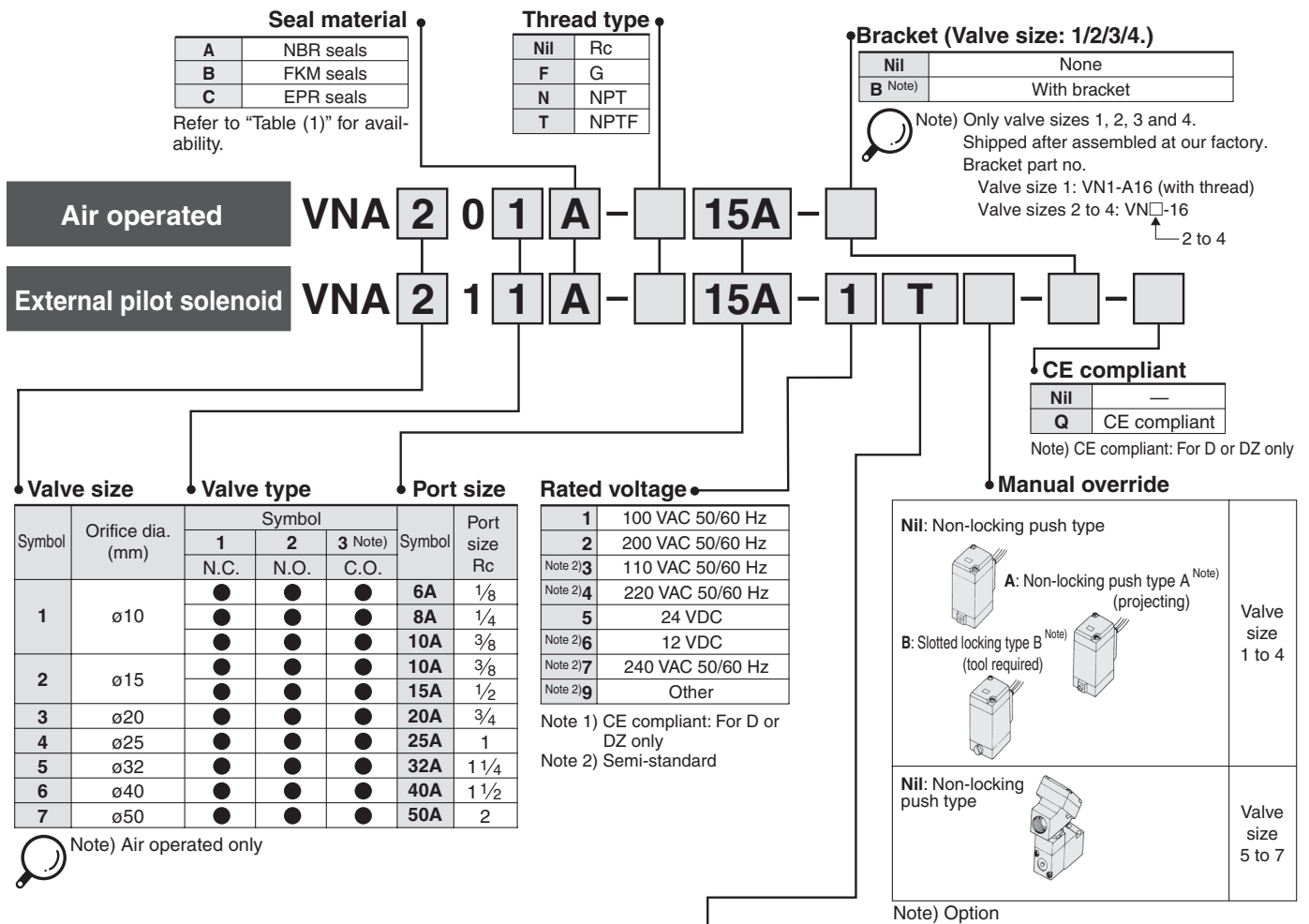

Table (1) Applicable Fluids

Model	VNA□□□A (Valve material: NBR seal)	VNA□□□B (Valve material: FKM seal)	VNA□□□C (Valve material: EPR seal)
Fluid	Air (Standard, Dry) Carbon dioxide (CO ₂) (Less than 0.7 MPa) Nitrogen gas (N ₂) Turbine oil, (Kinematic viscosity) Hydraulic fluid (40 to 100 mm ² /s)	Argon Helium Turbine oil, (Kinematic viscosity) Hydraulic fluid (40 to 100 mm ² /s)	Carbon dioxide (CO ₂) (0.7 MPa or more)

Caution

This product cannot be used for water application.



Note 1) Except rated voltage 6, 7, 9.

Note 2) For valve sizes 5 to 7 of the DZ DIN terminal with light/surge voltage suppressor, be sure to add suffix -X200 at the end of the part number. (For CE compliant product, -X200 is not required.)
In this case, the pilot solenoid valve is VO307-□DZ.

Electrical entry/With light/surge voltage suppressor

Symbol	Electrical entry	Valve size
G	Grommet	Valve size 1 to 4
GS	Grommet with surge voltage suppressor	
E	Grommet terminal	
EZ	Grommet terminal with light/surge voltage suppressor	
T	Conduit terminal	Valve size 5 to 7
TZ	Conduit terminal with light/surge voltage suppressor	
D	DIN terminal	
DZ	DIN terminal with light/surge voltage suppressor	
G	Grommet	Valve size 1 to 4
GS	Grommet with surge voltage suppressor	
C	Conduit	
T	Conduit terminal	
TS	Conduit terminal with surge voltage suppressor	Note 2) Valve size 5 to 7
TZ (Note 1)	Conduit terminal with light/surge voltage suppressor	
TL (Note 1)	Conduit terminal with indicator light	
D	DIN terminal	
DL	DIN terminal with indicator light	Valve size 1 to 7
DZ	DIN terminal with light/surge voltage suppressor	

CE compliant

D	DIN terminal	Valve size 1 to 7
DZ	DIN terminal with light/surge voltage suppressor	

Process Valve: 2 Port Valve For Compressed Air and Air-hydro Circuit Control **Series VNA**

Model

Model	Port size Rc	Orifice diameter ø (mm)	Flow characteristics				Mass (kg)	
			Measured by air		Measured by water ^{Note)}		Air operated	External pilot solenoid
			C [dm ³ / (bar·sec)]	b	Cv	Av x 10 ⁻⁶ m ²		
VNA1□□□-6A	1/8	10	3.5	0.35	0.88	25	0.1	0.2
VNA1□□□-8A	1/4		5.9	0.24	1.5	41		
VNA1□□□-10A	3/8		7.9	0.16	1.9	51		
VNA2□□□-10A	1/2	15	16	0.35	3.8	110	0.3	0.4
VNA2□□□-15A			23	0.25	4.8	130		
VNA3□□□-20A		3/4	20	34	0.16	7.5		

Note) This product cannot be used for water application.

Model	Port size Rc	Orifice diameter ø (mm)	Flow characteristics		Mass (kg)	
			Cv	Effective area (mm) ²	Air operated	External pilot solenoid
VNA4□□□-25A	1	25	12	220	0.8	0.9
VNA5□□□-32A	1 1/4	32	18	320	1.3	1.4
VNA6□□□-40A	1 1/2	40	28	500	2.1	2.2
VNA7□□□-50A	2	50	43	770	3.1	3.2

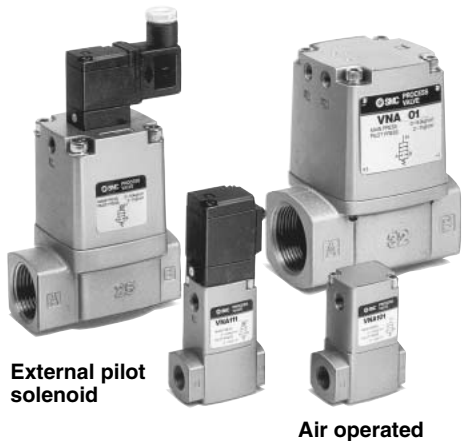

Specifications

Fluid (Main piping)		Refer to "Table (1)" on page 358.
Fluid temperature	VNA□□□ A	-5 to 60°C ^{Note 1)}
	VNA□□□ B	-5 to 99°C ^{Note 1)}
	□□□ C	(Air operated type only)
Ambient temperature		-5 to 50°C ^{Note 1)} (Air operated type: 60°C)
Proof pressure		1.5 MPa
Operating pressure range		0 to 1 MPa
External pilot air	Pressure range	0.2 to 0.7 MPa
	Lubrication	Not required (Use turbine oil Class 1 ISO VG32, if lubricated. ^{Note 2)})
	Temperature	-5 to 50°C ^{Note 1)} (Air operated type: 60°C)
Mounting orientation		Unrestricted ^{Note 3)}

Note 1) No freezing
 Note 2) Lubrication is not allowed for use with EPR seal material.
 Note 3) For external pilot solenoid, it is recommended that the pilot solenoid valve be oriented either vertically upward or horizontally.

JIS Symbol

Style	Valve type	N.C.	N.O.	C.O.
		Normally closed	Normally open	Double acting
Air operated		VNA□01	VNA□02	VNA□03
External pilot solenoid		VNA□11	VNA□12	

Pilot Solenoid Valve Specifications

Port size		6A to 25A	32A to 50A	32A to 50A (CE compliant)
Pilot solenoid valve		SF4-□□□-23	VO301-00□□□	VO307-00□□□z-Q
Electrical entry		Grommet, Grommet terminal Conduit terminal DIN terminal	Grommet, Conduit DIN terminal Other (Option)	DIN terminal
Coil rated voltage (V)	AC (50/60 Hz)	100 V, 200 V, Other voltage (Option)		
	DC	24 V, Other voltage (Option)		
Allowable voltage fluctuation		-15% to +10% of rated voltage		
Temperature rise		35°C or less (When rated voltage is applied.)	70°C or less (When rated voltage is applied.)	50°C or less (When rated voltage is applied.)
Apparent power	AC	Inrush	5.6 VA (50 Hz), 5.0 VA (60 Hz)	12.7 VA (50 Hz), 10.7 VA (60 Hz)
		Holding	3.4 VA (50 Hz), 2.3 VA (60 Hz)	7.5 VA (50 Hz), 6 VA (60 Hz)
Power consumption	DC	1.8 W (without light), 2 W (with light)	4.8 W (without light), 5 W (with light)	
Manual override		Non-locking push type Other (Option)		Non-locking push type

Note) For "How to Order" pilot solenoid valves, refer to page 363.

VNA

VNB

SGC

VNC

VNH

VND

VCC

Construction

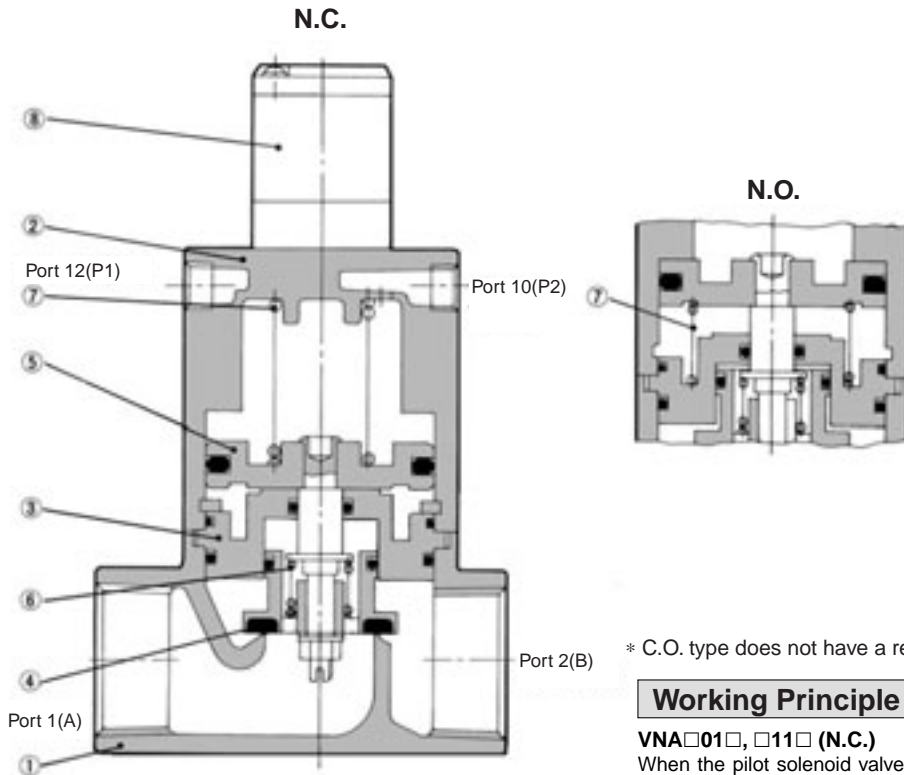

* C.O. type does not have a return spring ⑦.

Working Principle

VNA□01□, □11□ (N.C.)

When the pilot solenoid valve ⑧ is not energized (or when air is exhausted from the port 12(P1) of the air operated style), the valve element ④ linked to the piston ⑤ is closed by the return spring ⑦.

● When valve element opens

When the pilot solenoid valve is energized (or when pressurized air enters through the port 12(P1) of the air operated style), the pilot air that has entered under the piston moves upward to open the valve element.

● When valve element closes

When the power to the pilot solenoid valve is turned off (or when fluid is exhausted from the port 12(P1) of the air operated style), the pilot air under the piston is exhausted, and the return spring closes the valve element.

VNA□02□, □12□ (N.C.)

In contrast with the N.C., when the power to the pilot solenoid valve is turned off (or when air is exhausted from the port 10(P2) of the air operated style), the valve is held open by the return spring. When the pilot solenoid valve is energized (or when pressurized air enters through the port 10(P2) of the air operated style), the valve element closes.

VNA□03□ (C.O.)

The valve element of the C.O. type, which has no return spring, is in an arbitrary position when air is exhausted through the ports 12(P1) and 10(P2). When pressurized air enters the port 12(P1) (exhaust from the port 10(P2)), the valve element opens, and it closes when pressurized air enters the port 10(P2) (exhaust from the port 12(P1)).

Component Parts

No.	Description	Material	Note
1	Body	Aluminum alloy	Platinum silver painted
2	Cover assembly	Aluminum alloy	Platinum silver painted
3 Note)	Plate assembly	Aluminum alloy	Valve material (NBR, FKM, EPR)
4 Note)	Valve element	Aluminum alloy	Valve material (NBR, FKM, EPR)
5	Piston assembly	Aluminum alloy	—
6	Travel spring	Stainless steel	—
7	Return spring	Piano wire	—
8	Pilot solenoid valve	—	—



Note) Parts ③ and ④ are for selection of valve composition.

Replacement Parts

No.	Description		Part no.							
			VNA1□□A -6A, 8A, 10A	VNA2□□□ -10A, 15A	VNA3□□□ -20A	VNA4□□□ -25A	VNA5□□□ -32A	VNA6□□□ -40A	VNA7□□□ -50A	
3	Plate assembly	Seal material	NBR	VN1-A3AA	VN2-A3AA	VN3-A3AA	VN4-A3AA	VN5-A3AA	VN6-A3AA	VN7-A3AA
		FKM	VN1-A3AB	VN2-A3AB	VN3-A3AB	VN4-A3AB	VN5-A3AB	VN6-A3AB	VN7-A3AB	
		EPR	VN1-A3AC	VN2-A3AC	VN3-A3AC	VN4-A3AC	VN5-A3AC	VN6-A3AC	VN7-A3AC	
4	Valve disc (Valve disc assembly for 25A-50A)	Seal material	NBR	VN1-4AA	VN2-4AA	VN3-4AA	VN4-A4AA	VN5-A4AA	VN6-A4AA	VN7-A4AA
		FKM	VN1-4AB	VN2-4AB	VN3-4AB	VN4-A4AB	VN5-A4AB	VN6-A4AB	VN7-A4AB	
		EPR	VN1-4AC	VN2-4AC	VN3-4AC	VN4-A4AC	VN5-A4AC	VN6-A4AC	VN7-A4AC	
8	Pilot solenoid valve		SF4-□□□-23 (Refer to page 363 for details.)				VO301-00□□□ (Refer to page 363 for details.)			

Process Valve: 2 Port Valve For Compressed Air and Air-hydro Circuit Control **Series VNA**

Port size: 6A, 8A, 10A

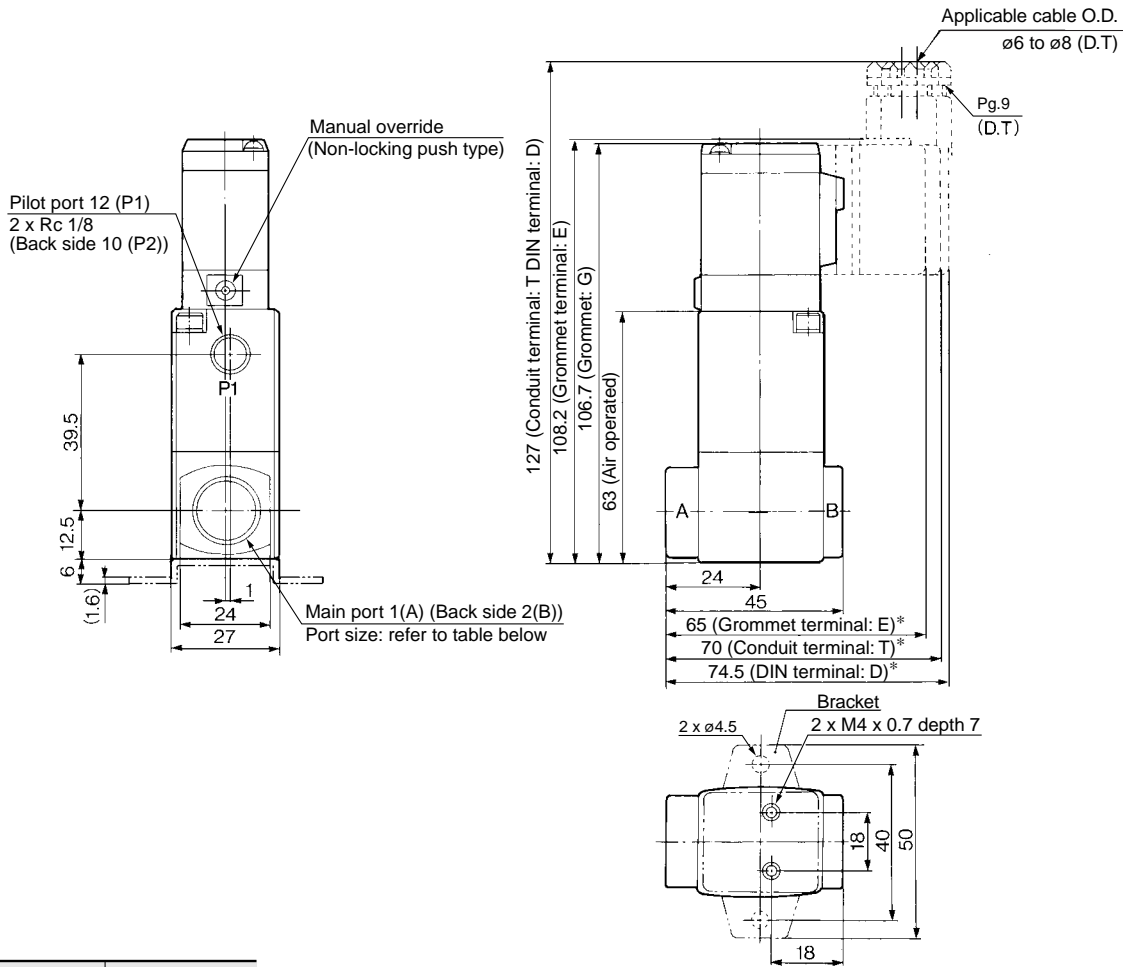

Model	Main port 1(A), 2(B)
VNA1□□□-6A	1/8
VNA1□□□-8A	1/4
VNA1□□□-10A	3/8



* In the case of "EZ" or "TZ", the length is longer by 10 mm. For "DZ", the length is longer by 17 mm.

VNA

VNB

SGC

VNC

VNH

VND

VCC

Series VNA

Port size: 10A, 15A, 20A, 25A

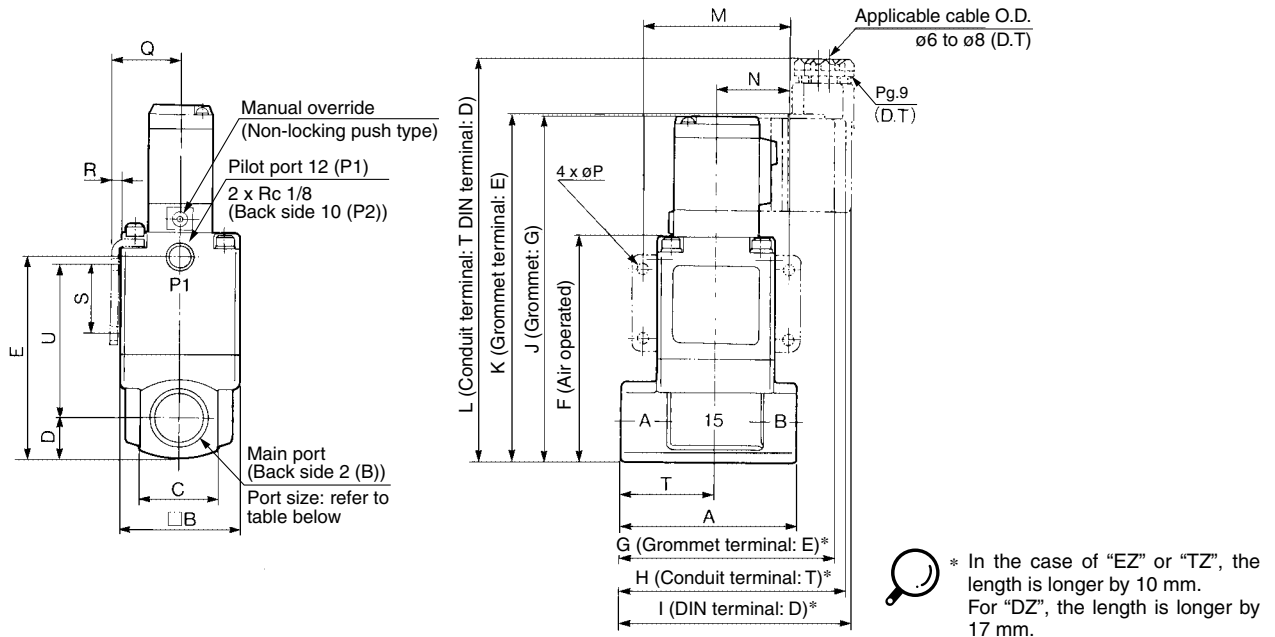

Model	Main port 1(A), 2(B)	A	B	C	D	E	F	G	H	I	J	K	L	M	N	P	Q	R	S	T	U
VNA2□□□-10A	3/8	63	42	28	14	72.5	80.5	75	80	84.5	124	125.5	144.5	52	26	4.5	24.3	2.3	25	34	55
VNA2□□□-15A	1/2																				
VNA3□□□-20A	3/4	80	50	35	17.5	84	92	84	89	93.5	135.5	137	156	62	31	5.5	28.3	2.3	30	43	60.5
VNA4□□□-25A	1	90	60	40	20	100	108	90	95	99.5	151.5	153	172	72	36	6.5	33.3	2.3	35	49	73

Port size: 32A, 40A, 50A

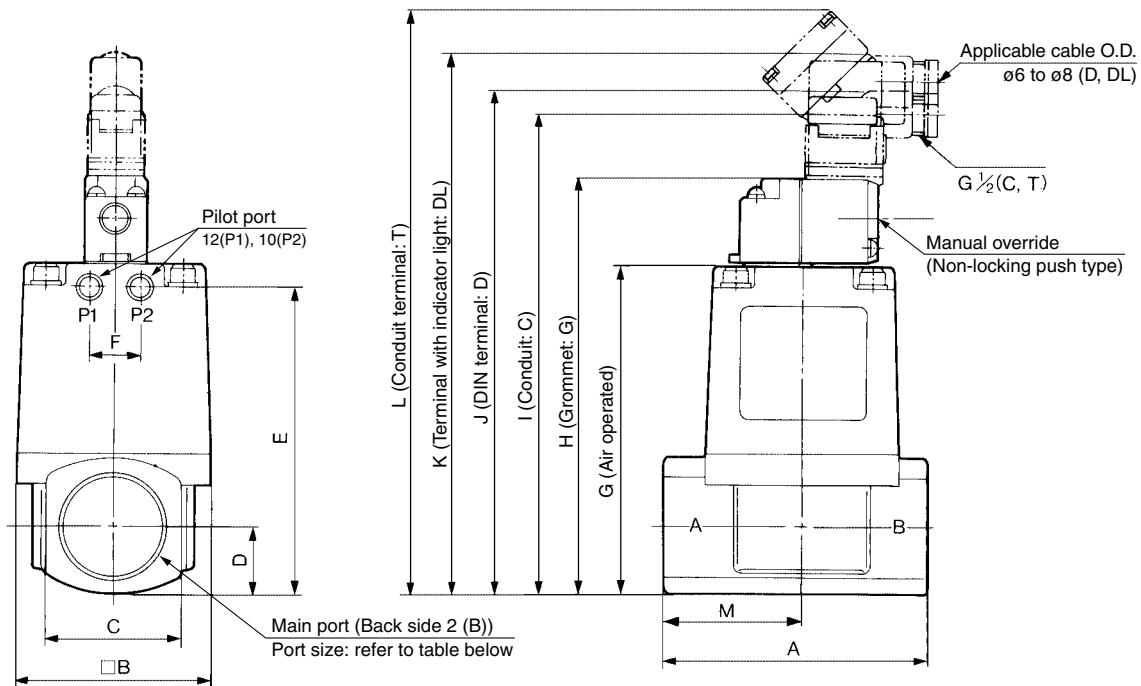

Model	Main port 1(A), 2(B)	Pilot port 12(P1), 10(P2)	A	B	C	D	E	F	G	H	I	J (Note)	K	L	M
VNA5□□□-32A	1 1/4	1/8	105	77	53	26.5	120.5	20	129.5	163	175.5	219 (215.5)	223	229.5	55
VNA6□□□-40A	1 1/2	1/4	120	96	60	30	137	24	147	180.5	193	236 (233)	240.5	247	63
VNA7□□□-50A	2	1/4	140	113	74	37	160	24	170	203.5	216	259 (256)	263.5	270	74

Note) (): CE compliant product (-Q)

Process Valve: 2 Port Valve
For Compressed Air and Air-hydro Circuit Control *Series VNA*

How to Order Pilot Solenoid Valves

Valve size 1/2/3/4

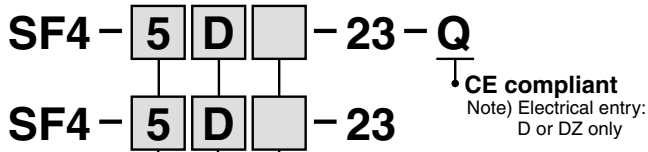

Coil rated voltage

1	100 VAC 50/60 Hz
2	200 VAC 50/60 Hz
3*	110 VAC 50/60 Hz
4*	220 VAC 50/60 Hz
5	24 VDC
6*	12 VDC
7*	240 VAC 50/60 Hz
9*	Other

Manual override

Nil	Non-locking push type
A*	Non-locking push type A (projecting)
B*	Slotted locking type B (tool required)

* Semi-standard

**Electrical entry/
With light/surge voltage suppressor**

		CE compliant
G	Grommet	—
GS	Grommet with surge voltage suppressor	—
E	Grommet terminal	—
EZ	Grommet terminal with light/surge voltage suppressor	—
T	Conduit terminal	—
TZ	Conduit terminal with light/surge voltage suppressor	—
D	DIN terminal	●
DZ	DIN terminal with light/surge voltage suppressor	●

* Semi-standard

Valve size 5/6/7

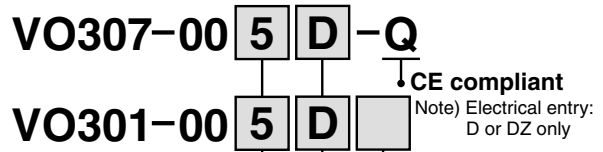

Coil rated voltage

1	100 VAC 50/60 Hz
2	200 VAC 50/60 Hz
3*	110 VAC 50/60 Hz
4*	220 VAC 50/60 Hz
5	24 VDC
6*	12 VDC
7*	240 VAC 50/60 Hz
9*	Other

* Semi-standard

With surge voltage suppressor

Nil	None
S	Surge voltage suppressor (Except "DZ, DL")

Electrical entry

		CE compliant
G	Grommet	—
C	Conduit	—
T <small>Note 1)</small>	Conduit terminal	—
D	DIN terminal	●
DZ <small>Note 2)</small>	DIN terminal with light/surge voltage suppressor	●
DL <small>Note 3)</small>	DIN terminal with indicator light	—

Note 1) When the electrical entry is T, the pilot solenoid valve parts are as follows;

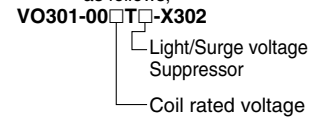

Note 2) VO307 only
Note 3) Semi-standard

Accessory

Function plate for VO301 (D seal, with screw): DXT060-32-4A
Function plate for VO307 (D seal, with screw): DXT152-14-1A

- VNA
- VNB
- SGC
- VNC
- VNH
- VND
- VCC



Series VNA Specific Product Precautions

Be sure to read before handling. Refer to front matters 42 and 43 for Safety Instructions, and pages 17 to 19 for 2 Port Solenoid Valves for Fluid Control Precautions.

External Pilot

⚠ Caution

1. Pilot port piping

12(P1) and 10(P2) piping should be as follows according to the model

Port	VNA□01□	VNA□02□	VNA□03□	VNA□1 ¹ □
12 (P1)	External pilot	Bleed port	External pilot	External pilot
10 (P2)	Bleed port	External pilot	External pilot	Pilot exhaust

Installing a silencer to the exhaust port and the bleed port is recommended for noise reduction and for dust entry prevention.

Piping

⚠ Caution

When high temperature fluids are used, use fittings and tubing with heat resistant features.

(Self-align fittings, Teflon® tubing, Copper tubing, etc.)

Mounting Direction of Pilot Solenoid Valve

⚠ Warning

With external pilot solenoids, the pilot solenoid valves are not splash proof specifications, and so care must be taken not to get fluid on oneself such as when performing maintenance.

⚠ Caution

Direction of mounting

When replacing a valve, if an external pilot solenoid valve is mounted in the wrong direction, it may malfunction or leak air.

Use with Air-hydro Unit

⚠ Caution

1. Piping

Surge pressure is generated between the cylinder and the VNA during intermediate stoppage.

To directly thread in the cylinder, use durable fittings (Stainless steel square nipples etc.) instead of ductile iron fittings (JIS B 2301) or steel pipe fittings (JIS B 2302).

When VNA is installed away from the cylinder, use a high-pressure rubber hose (JIS B 6349) instead of steel pipe, when possible.

⚠ Caution

1. Air bleeding

Series VNA valves have no air bleeding port. Bleed air comes from the middle piping. Bleeding by a vacuum pump is more effective.

2. Hydraulic fluid

Turbine oil, Grade 1 ISO VG32, with petroleum hydraulic fluid is recommended.

3. Speed control valve

The combination shown in the following table is recommended for best performance of the Series VNA. (Piping: JIS K 6349 high pressure hose)

Combination between Series-VNA and Speed control valve (Series AS)

	VNA	AS	Piping (I.D.)
10A	111	420-03	3/8 B (ø9.5)
15A	211	420-04	1/2 B (ø12.7)
20A	311	500-06	3/4 B (ø19.1)
25A	411	600-10	1 B (ø25.4)
32A	511	800-12	1 1/4 B (ø31.8)
40A	611	900-14	1 1/2 B (ø38.1)
50A	711	900-20	2 B (ø50.8)

Process Valve

Series VNB

2 Port Valve For Flow Control

A wide variety of applicable fluids

Proper selection with body and sealing materials permits application with a wide variety of fluids such as air, water, oil, gas and vacuum.

Cylinder actuation by external pilot air

Wide variations

N.C., N.O., C.O., types are available. Screw-in type (6A to 50A) and the flange (32F to 50F) are standardized.

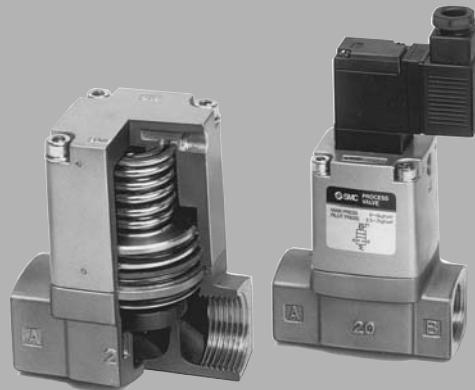

Air operated

External pilot solenoid



Selection Procedure

1 Applicable fluids

- Refer to "Table (1)" to check that the desired fluid is applicable.
- Select the body and sealing materials, depending on the fluid.

2 Flow characteristics (Air, Water)

- To find the flow rate of air or water, refer to the table of flow rate characteristics on page 10 to 16. Use the flow rate calculation equation to find the exact answer. Although the flow rate is the same, the operating pressure differs according to the valve size. Therefore, select the proper valve size from applicable valves.
- Refer to "Table (2)" to select the port size of the threaded type (6A to 50A) and flanges (32F to 50F).

3 Construction

- Select the air operated or external pilot solenoid styles. Valves come in N.C. (normally closed), N.O. (normally open), C.O. (double acting), and N.C. 1 MPa (normally closed) types. Select the proper one according to the operating conditions.

4 Power voltage and electrical entry (External pilot solenoid)

- Select the AC/DC power source and choose the electrical entry according to "Table (3)".

Table (1) Applicable Fluids Check List

Wetted part Body material	Copper alloy: Standard			Aluminum: L			Stainless steel: S		
	NBR : A	FKM : B	EPR : C	NBR : A	FKM : B	EPR : C	NBR : A	FKM : B	EPR : C
Wetted part Seal material									
Fluid									
Air (Standard, Dry)	●	●		●	●		●	●	
Low vacuum (Up to -101kPa)	●	●		●	●		●	●	
Carbon dioxide (CO ₂ , 0.7 MPa or less)	●	●		●	●		●	●	
Carbon dioxide (CO ₂ , 0.7 to 1 MPa)	●	●		●	●		●	●	
Nitrogen gas (N ₂)	●	●	●	●	●	●	●	●	●
Argon	●	●		●	●		●	●	
Helium	●	●		●	●		●	●	
Water (standard, up to 60°C)	●	●		●	●		●	●	
Water (up to 99°C air operated type only)	●	●	●	●	●		●	●	●
Turbine oil	●	●		●	●		●	●	
Spindle oil	●	●		●	●		●	●	
Fuel oil Class 3 (C fuel oil)	●	●		●	●		●	●	
Brake oil ^{Note)}	●	●	●	●	●	●	●	●	●
Silicon oil	●	●		●	●		●	●	
Naphtha	●	●		●	●		●	●	
Ethylene glycol (up to 80°C)	●	●		●	●		●	●	
Boiler water	●	●		●	●		●	●	

⚠ Caution

Note 1) When fluid permits application of multiple body and sealing materials, select the most suitable one according to the ambient environment (FKM or EPR seal material for high temperature) and other conditions (corrosion resistance and viscosity), etc.

Note 2) Test fluids to see if it will wash out cleaning liquid such as grease.

Note 3) Some brake oils are not allowed.

Table (2) Combinations between Valve Size and Port Size

Valve size	Port size											
	6A	8A	10A	15A	20A	25A	32A	32F	40A	40F	50A	50F
1	●	●	●									
2			●	●								
3				●	●							
4					●	●						
5							●	●				
6									●	●		
7											●	●

Table (3) Combinations between Electrical Entry and Light/Surge Voltage Suppressor

Valve size	Electrical entry						Light/Surge voltage suppressor			Manual override
	G	E	C	T	D	DL	S	Z	L	
1, 2, 3, 4	●	●	●	●	●	●	●	●	●	●
5, 6, 7	●	●	●	●	●	●	●	●	●	●

(Only "G") (Except "G")
(Except "DL") (Only "T") (Only "T")

VNA

VNB

SGC

VNC

VNH

VND

VCC

Process Valve: 2 Port Valve For Flow Control Series VNB



[Option]

* Electrical entry: D or DZ only.

How to Order

Seal material

A	NBR seals
B	FKM seals
C	EPR seals

Refer to Table (1) for availability.

Body material option

Nil	Standard
S*	Stainless steel body
L*	Aluminum body

* Threaded port only

Pilot system option

Nil	Standard
V	Vacuum pilot type

Note) Symbol V is for vacuum pilot valve specification, for both main pressure and pilot pressure, valve size 2 to 7.

Thread type

Nil	Rc
F	G
N	NPT
T	NPTF

Bracket (valve size: 1/2/3/4.)

Nil	None
B ^{Note)}	With bracket

Note) Only valve sizes 1, 2, 3 and 4. Shipped after assembled at our factory. Bracket part no.
Valve size 1: VN1-A16 (with thread)
Valve sizes 2 to 4: VN□-16
← 2 to 4

Air operated VNB **2** **0** **1** **A** □ □ - □ □ **15A** - □ □

External pilot solenoid VNB **2** **1** **1** **A** □ □ - □ □ **15A** - **1** **T** □ □ - □ □ - □ □

Valve size **Valve type** **Port size**

Symbol	Orifice dia. (mm)	Symbol				Symbol	Port size Rc
		1		4			
		N.C. 0.5 MPa	N.O. 1 MPa	C.O. 1 MPa	N.C. 1 MPa		
1	ø7	—	●	●	●	6A	1/8
		—	●	●	●	8A	1/4
		—	●	●	●	10A	3/8
2	ø11	—	—	—	●	10A	3/8
		●	●	●	—	15A	1/2
		●	●	●	—	—	—
3	ø14	—	—	—	●	—	—
	ø20	●	●	●	—	20A	3/4
4	ø16	—	—	—	●	—	—
	ø25	●	●	●	—	25A	1
5	ø22	—	—	—	●	—	—
	ø32	●	●	●	—	32A	1 1/4
	ø32	●	●	—	—	32F	1 1/4 B Flange
6	ø28	—	—	—	●	—	—
	ø40	●	●	●	—	40A	1 1/2
	ø40	●	●	—	—	40F	1 1/2 B Flange
7	ø33	—	—	—	●	—	—
	ø50	●	●	●	—	50A	2
	ø50	●	●	—	—	50F	2B Flange

Note 1) Air operated only
Note 2) The valve type symbols for vacuum pilot type are 1 (N.C.) and 2 (N.O.) only.

Graph (4) VNB□□□□ Pilot Pressure (N.O. and C.O. types)

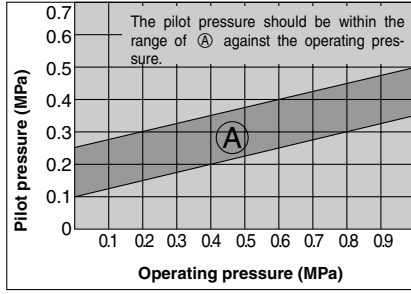

Rated voltage

1	100 VAC 50/60 Hz
2	200 VAC 50/60 Hz
Note 2) 3	110 VAC 50/60 Hz
Note 2) 4	220 VAC 50/60 Hz
5	24 VDC
Note 2) 6	12 VDC
Note 2) 7	240 VAC 50/60 Hz
Note 2) 9	Other

Note 1) Electrical entry: D or DZ only
Note 2) Semi-standard

CE compliant

Nil	—
Q	CE compliant*

* Electrical entry: D or DZ only

Manual override

<p>Nil: Non-locking push type</p>	<p>A: Non-locking push type A (projecting)</p>	Valve size 1 to 4
<p>B: Slotted locking type B (tool required)</p>	<p>Note) Semi-standard</p>	
<p>Nil: Non-locking push type</p>	<p>Note) Semi-standard</p>	Valve size 5 to 7

Electrical entry/With light/surge voltage suppressor

Symbol	Electrical entry	Valve size
G	Grommet	Valve size 1 to 4
GS	Grommet with surge voltage suppressor	
E	Grommet terminal	
EZ	Grommet terminal with light/surge voltage suppressor	
T	Conduit terminal	Valve size 5 to 7
TZ	Conduit terminal with light/surge voltage suppressor	
D	DIN terminal	
DZ	DIN terminal with light/surge voltage suppressor	
G	Grommet	
GS	Grommet with surge voltage suppressor	
C	Conduit	
T	Conduit terminal	
TS	Conduit terminal with surge voltage suppressor	
TZ ^{Note 1)}	Conduit terminal with light/surge voltage suppressor	
TL ^{Note 1)}	Conduit terminal with indicator light	
D	DIN terminal	
DL	DIN terminal with indicator light	

CE compliant

Symbol	Electrical entry	Valve size
D	DIN terminal	Valve size 1 to 7
DZ	DIN terminal with light/surge voltage suppressor	

Note 1) Except rated voltage 6, 7, 9.
Note 2) For valve sizes 5 to 7 of the DZ DIN terminal with light/surge voltage suppressor, be sure to add suffix -X200 at the end of the part number. (For CE compliant product, -X200 is not required.) In this case, the pilot solenoid valve is VO307-□DZ.



Process Valve: 2 Port Valve For Flow Control **Series VNB**

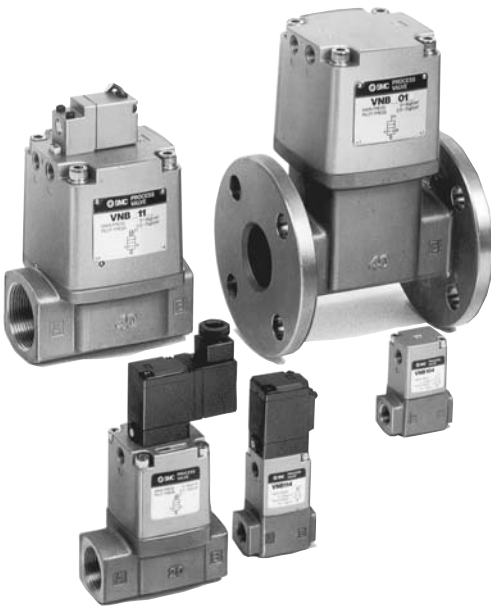

Model

Model	Port size Rc	Orifice dia. ø (mm)	Flow characteristics			Mass (kg)		
			Measured by air		Measured by water	Air operated	External pilot solenoid	
			C [dm ³ /(bar·sec)]	b	Cv			Av x 10 ⁻⁶ m ²
VNB1□□□-6A	1/8	7	3.3	0.29	0.80	0.3	0.4	
VNB1□□□-8A	1/4		4.6	0.17	1.0			29
VNB1□□□-10A	3/8		4.7	0.18	1.1			31
VNB2□4□-10A		11	9.6	0.40	2.6	71		
VNB2□□□-10A	1/2	15	17	0.32	4.0	0.6	0.7	
VNB2□4□-15A		11	9.6	0.40	2.6			76
VNB2□□□-15A		15	19	0.24	4.8			140
VNB3□4□-20A	3/4	14	18	0.42	5.4	0.9	1.0	
VNB3□□□-20A		20	35	0.13	7.4			270

Model	Port size		Orifice dia. ø (mm)	Flow characteristics		Mass (kg)	
	Rc	Flange ^{Note)}		Cv	Effective area (mm ²)	Air operated	External pilot solenoid
VNB4□4□-25A	1	-	16	7	130	1.4	1.5
VNB4□□□-25A			25	12	220		
VNB5□4□-32A	1 1/4	-	22	11	210	2.5	2.6
VNB5□□□-32A			32	18	320		
VNB5□4□-32F	-	32	22	11	210	5.7	5.8
VNB5□□□-32F			32	18	320		
VNB6□4□-40A	1 1/2	-	28	19	330	4.1	4.2
VNB6□□□-40A			40	28	500		
VNB6□4□-40F	-	40	28	19	330	7.7	7.8
VNB6□□□-40F			40	28	500		
VNB7□4□-50A	2	-	33	29	520	6.3	6.4
VNB7□□□-50A			50	43	770		
VNB7□4□-50F	-	50	33	29	520	11.4	11.5
VNB7□□□-50F			50	43	770		

Note) The flange should be JIS B 2210 10K (ordinary style) or its equivalent.

JIS Symbol

Type	Valve type	N.C.	N.O.	C.O.
		Normally closed	Normally open	Double acting
Air operated		VNB□0□	VNB□02	VNB□03
		12 (P1) 1 (A) 2 (B)	10 (P2) 1 (A) 2 (B)	12 (P1) 1 (A) 2 (B) 10 (P2)
External pilot solenoid		VNB□1□	VNB□12	
		12 (P1) 1 (A) 2 (B)	12 (P1) 1 (A) 2 (B)	

Note) Flow direction should be from port 1(A) to port 2(B) for vacuum applications.

Option Specifications

Vacuum pilot valve VNB□□□□V

(Valve size 2 to 7)

It is used when the valve is to be operated by the main vacuum in the absence of pressurized air.

Specifications (Vacuum pilot type)

Fluid	Vacuum
Operating pressure range	-101 kPa to Atmospheric pressure
Pilot pressure range	-101 to -47.9 kPa

JIS Symbol (Vacuum pilot type)

Type	Valve type	N.C.	N.O.
		Normally closed	Normally open
Air operated		VNB□01□V	VNB□02□V
		12 (P1) 1 (A) 2 (B)	12 (P1) 1 (A) 2 (B)
External pilot solenoid		VNB□11□V	VNB□12□V
		12 (P1) 1 (A) 2 (B)	12 (P1) 1 (A) 2 (B)

Specifications

Fluid	Water/Oil/Air/Vacuum, etc.		
Fluid temperature	VNB□□□A, VNB□1□□	-5 to 60°C ^{Note 1)}	
	VNB□0□□	-5 to 99°C ^{Note 1)} (Water, Oil etc. Air Operated only)	
Ambient temperature	-5 to 50°C ^{Note 1)} (Air operated type: 60°C)		
Proof pressure	1.5 MPa		
Applicable ^{Note 4)} pressure range	VNB□□1□	Low vacuum to 0.5 MPa	
	VNB□□□□	Low vacuum to 1 MPa	
External pilot air	Pressure	VNB□□□□	0.25 to 0.7 MPa
		VNB□□□□	0.1 + 0.25 x (Operating pressure) to 0.25 + 0.25 x (Operating pressure) MPa ^{Note 3)} Refer to "Graph (1)" on page 366.
	Lubrication	Not required (Use turbine oil Class 1 ISO VG32, if lubricated. ^{Note 2)}	
	Temperature	-5 to 50°C (Air operated type: 60°C)	
Mounting orientation	Unrestricted ^{Note 5)}		

Note 1) No freezing
 Note 2) Lubrication is not allowed in the case of seal material EPR.
 Note 3) Adjust the operating pressure range from 0.125 MPa to 0.275 MPa for low vacuum.
 Note 4) The pressure differential between Port 1 (A) and 2(B) must not exceed the maximum operating pressure.
 Note 5) For external pilot solenoid, it is recommended that the pilot solenoid valve be oriented either vertically upward or horizontally.

Pilot Solenoid Valve Specifications

Port size	6A to 25A		32A to 50A, 32F to 50F	32A to 50A, 32F to 50F, CE compliant
Pilot solenoid valve	SF4-□□□-23		VO301□-00□□□	VO307□-00□□□-Q
Electrical entry	Grommet, Grommet terminal, Conduit terminal, DIN terminal		Grommet, Conduit, DIN terminal, Other (Option)	DIN terminal
Coil rated voltage (V)	AC (50/60 Hz) DC		100 V, 200 V, other voltage (Semi-standard) 24 V, other voltage (Semi-standard)	
Allowable voltage fluctuation	-15% to +10% of rated voltage			
Temperature rise	35°C or less (when rated voltage is applied) 70°C or less (when rated voltage is applied) 50°C or less (when rated voltage is applied)			
Apparent power	AC	Inrush	5.6 VA (50 Hz), 5.0 VA (60 Hz) 12 VA (50 Hz), 10.5 VA (60 Hz) 12.7 VA (50 Hz), 10.7 VA (60 Hz)	
		Holding	3.4 VA (50 Hz), 2.3 VA (60 Hz) 7.5 VA (50 Hz), 6 VA (60 Hz) 7.6 VA (50 Hz), 5.4 VA (60 Hz)	
Power consumption	DC		1.8 W (without light), 2W (with light) 4.8 W (without light), 5 W (with light)	
Manual override	Non-locking push type Other (Semi-standard)		Non-locking push type	

Note 1) For "How to Order" pilot solenoid valves, refer to page 368.
 Note 2) Vacuum pilot type pilot solenoid valves will become VO301V-00□□□.
 Note 3) Vacuum pilot type CE compliant pilot solenoid valves will become VO307V-□□□-Q.

Series VNB

How to Order Pilot Solenoid Valves

Valve size 1/2/3/4

SF4-5D-23-Q
SF4-5D-23

CE compliant
 * Electrical entry: D or DZ only

Manual override

Nil	Non-locking push type
A*	Non-locking push type A (projecting)
B*	Slotted locking type B (tool required)

* Semi-standard

Electrical entry/With indicator light/surge voltage suppressor

G	Grommet	—
GS	Grommet with surge voltage suppressor	—
E	Grommet terminal	—
EZ	Grommet terminal with light/surge voltage suppressor	—
T	Conduit terminal	—
TZ	Conduit terminal with light/surge voltage suppressor	—
D	DIN terminal	●
DZ	DIN terminal with light/surge voltage suppressor	●

CE compliant

Coil rated voltage

1	100 VAC 50/60 Hz
2	200 VAC 50/60 Hz
3*	110 VAC 50/60 Hz
4*	220 VAC 50/60 Hz
5	24 VDC
6*	12 VDC
7*	240 VAC 50/60 Hz
9*	Other

* Semi-standard

Valve size 5/6/7 and vacuum pilot type

VO307-Q
VO301-00-Q

CE compliant
 * Electrical entry: D or DZ only

Body option

Nil	Standard
V	Vacuum pilot

With surge voltage suppressor

Nil	None
S	Surge voltage suppressor (Except "DZ, DL")

Coil rated voltage

1	100 VAC 50/60 Hz
2	200 VAC 50/60 Hz
3*	110 VAC 50/60 Hz
4*	220 VAC 50/60 Hz
5	24 VDC
6*	12 VDC
7*	240 VAC 50/60 Hz
9*	Other

* Semi-standard

Electrical entry

G	Grommet	—
C	Conduit	—
T (Note 1)	Conduit terminal	—
D	DIN terminal	●
DZ (Note 2)	DIN terminal with light/surge voltage suppressor*	●
DL (Note 3)	DIN terminal with indicator light	—

Note 1) When the electrical entry is T, the pilot solenoid valve parts are as follows;
VO301-00-T-X302
 Coil rated voltage — Light/Surge voltage suppressor

Note 2) VO307 only
 Note 3) Semi-standard

Construction

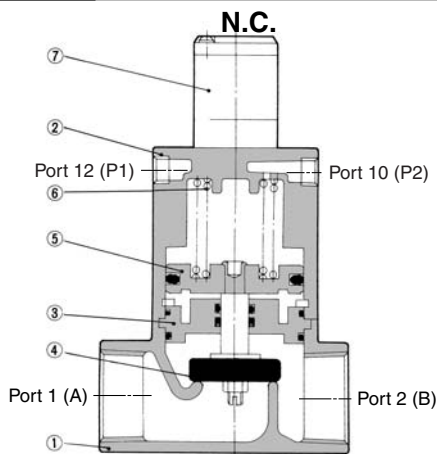

N.O.

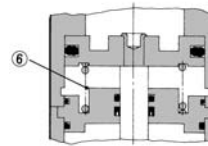

* C.O. type does not have a return spring ⑥.

Working Principle (Vacuum pilot type is excluded)

VNB□0□□, □1□□ (N.C.)

When the pilot solenoid valve ⑦ is not energized (or when air is exhausted from the port P1 of the air operated type), the valve element ④ linked to the piston ⑤ is closed by the return spring ⑥.

• When valve opens

When the pilot solenoid valve is energized (or when pressurized air enters through the port P1 of the air operated style), the pilot air that has entered under the piston moves upward to open the valve element.

• When valve closes:

When the power to the pilot solenoid valve is turned off (or when fluid is exhausted from the port P1 of the air operated style), the pilot air under the piston is exhausted, and the return spring closes the valve element.

VNB□02□, □12□ (N.O.)

In contrast with the N.C., when the power to the pilot solenoid valve is turned off (or when air is exhausted from the port P2 of the air operated style), the valve is held open by the return spring. When the pilot solenoid valve is energized (or when pressurized air enters through the port P2 of the air operated style), the valve element closes.

VNB□03□ (C.O.)

The valve element for the C.O. type, which has no return spring, is in an arbitrary position when air is exhausted through the ports P1 and P2. When pressurized air enters the port P1 (exhaust from the port P2), the valve element opens, and it closes when pressurized air enters the port P2 (exhaust from the port P1).

Component Parts

No.	Description	Material	Note
1	Body	Bronze (Note 2)	Clear coated
2	Cover assembly	Aluminum alloy	Platinum silver painted
3 (Note 1)	Plate assembly	Brass (Note 2)	Valve material (NBR, FKM, EPR)
4 (Note 1)	Valve element	Valve material (NBR, FKM, EPR)	Stainless steel or brass (Note 2)
5	Piston assembly	Aluminum alloy	—
6	Return spring	Piano wire	—
7	Pilot solenoid valve	—	—

Note 1) Parts ③ and ④ are for selection of valve composition.

Note 2) The body option "S" is stainless steel, and "L" is aluminum.

Replacement Parts

No.	Description	Part no.													
		VNB1□□□ -6A, 8A, 10A	VNB2□□□ -10A, 15A	VNB3□□□ -20A	VNB4□□□ -25A	VNB5□□□ -32A, 32F	VNB5□□ 4 -32A, 32F	VNB6□□□ -40A, 40F	VNB6□□ 4 -40A, -40F	VNB7□□□ -50A, 50F	VNB7□□ 4 -50A, 50F				
3 (Note 1)	Plate assembly	Seal material	NBR	FKM	EPR	Refer to Note 2)	VN2-A3BA	VN3-A3BA	VN4-A3BA	VN5-A3BA	VN5-A3BA	VN6-A3BA	VN6-A3BA	VN7-A3BA	VN7-A3BA
							VN2-A3BB	VN3-A3BB	VN4-A3BB	VN5-A3BB	VN5-A3BB	VN6-A3BB	VN6-A3BB	VN7-A3BB	VN7-A3BB
							VN2-A3BC	VN3-A3BC	VN4-A3BC	VN5-A3BC	VN5-A3BC	VN6-A3BC	VN6-A3BC	VN7-A3BC	VN7-A3BC
4 (Note 1)	Valve element (32° to 50° come in valve element assembly)	Seal material	NBR	FKM	EPR	Refer to Note 2)	VN2-4BA	VN3-4BA	VN4-4BA	VN5-A4BA	VN5-A4BA-3	VN6-A4BA	VN6-A4BA-3	VN7-A4BA	VN7-A4BA-3
							VN2-4BB	VN3-4BB	VN4-4BB	VN5-A4BB	VN5-A4BB-3	VN6-A4BB	VN6-A4BB-3	VN7-A4BB	VN7-A4BB-3
							VN2-4BC	VN3-4BC	VN4-4BC	VN5-A4BC	VN5-A4BC-3	VN6-A4BC	VN6-A4BC-3	VN7-A4BC	VN7-A4BC-3
7	Pilot solenoid valve	SF4-□□□-23 (Refer to the table below.)					VO301□-00□□□ (Refer to the table below.)								



Note 1) In the case of body options "S" and "L", the materials of the part nos. ③ and ④ are as follows: (Example): **VN1-A3B□A**

However all brackets of valve element VNB 1 to 4 are made of stainless steel. (No need to add options "S" and "L".) L: Aluminum, S: Stainless steel

Note 2) Please request a factory repair.

Port size: 6A, 8A, 10A

Standard

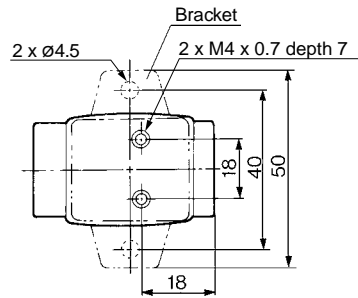
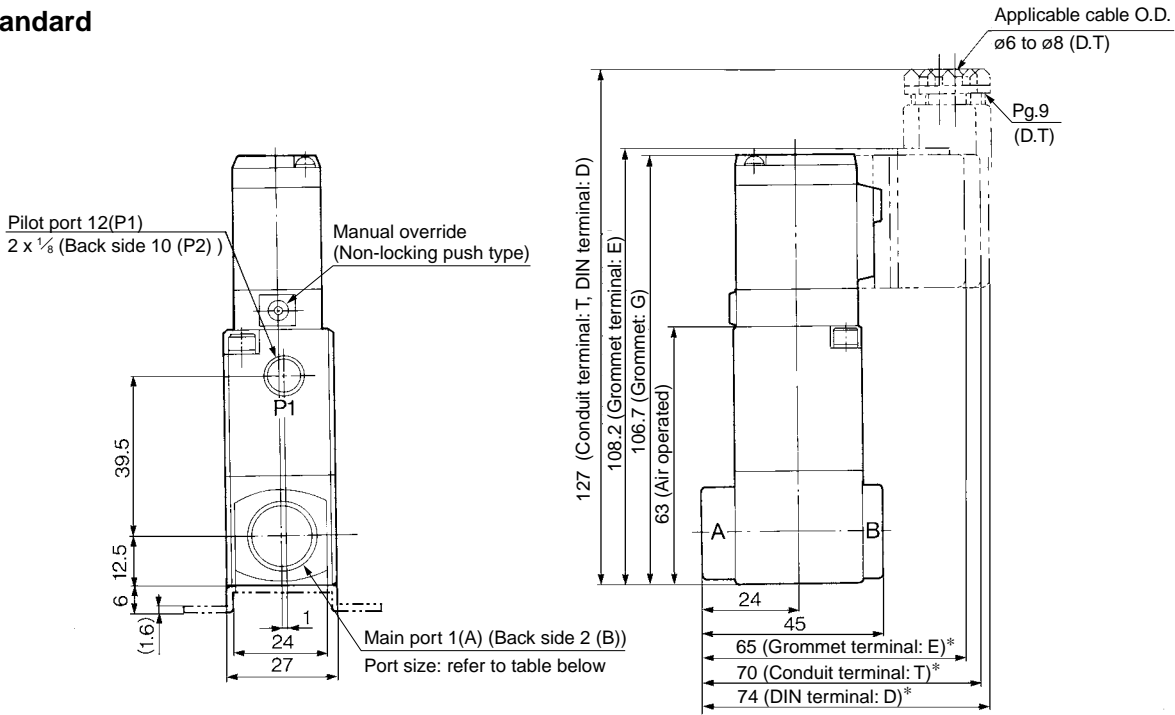

* In the case of "EZ" or "TZ", the length is longer by 10 mm.
For "DZ", the length is longer by 17 mm.

Model	Main port 1(A), 2(B)
VNB1□□□-6A	1/8
VNB1□□□-8A	1/4
VNB1□□□-10A	3/8

VNA

VNB

SGC

VNC

VNH

VND

VCC

Series VNB

Port size: 10A, 15A, 20A, 25A

Standard

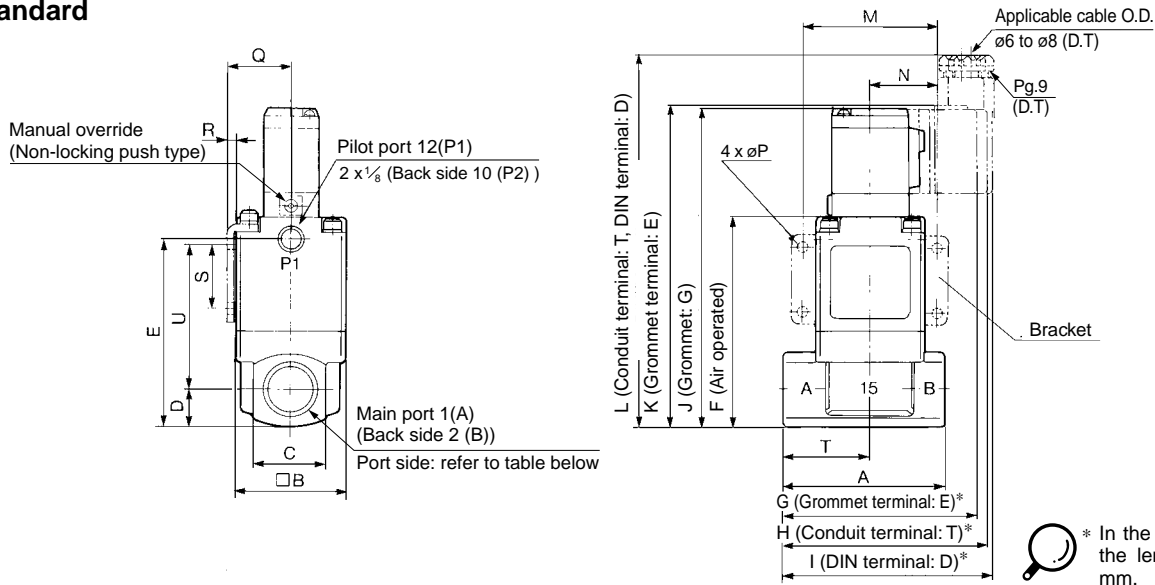

Model	Main port 1(A), 2(B)	A	B	C	D	E	F	G	H	I	J	K	L	M	N	P	Q	R	S	T	U
VNB2□□□-10A	3/8	63	42	28	14	72.5	80.5	75	80	84.5	124	125.5	144.5	52	26	4.5	24.3	2.3	25	34	55
VNB2□□□-15A	1/2	80	50	35	17.5	84	92	84	89	93.5	135.5	137	156	62	31	5.5	28.3	2.3	30	43	60.5
VNB3□□□-20A	3/4	90	60	40	20	100	108	90	95	99.5	151.5	153	172	72	36	6.5	33.3	2.3	35	49	73
VNB4□□□-25A	1																				

Port size: 10A, 15A, 20A, 25A

Vacuum pilot

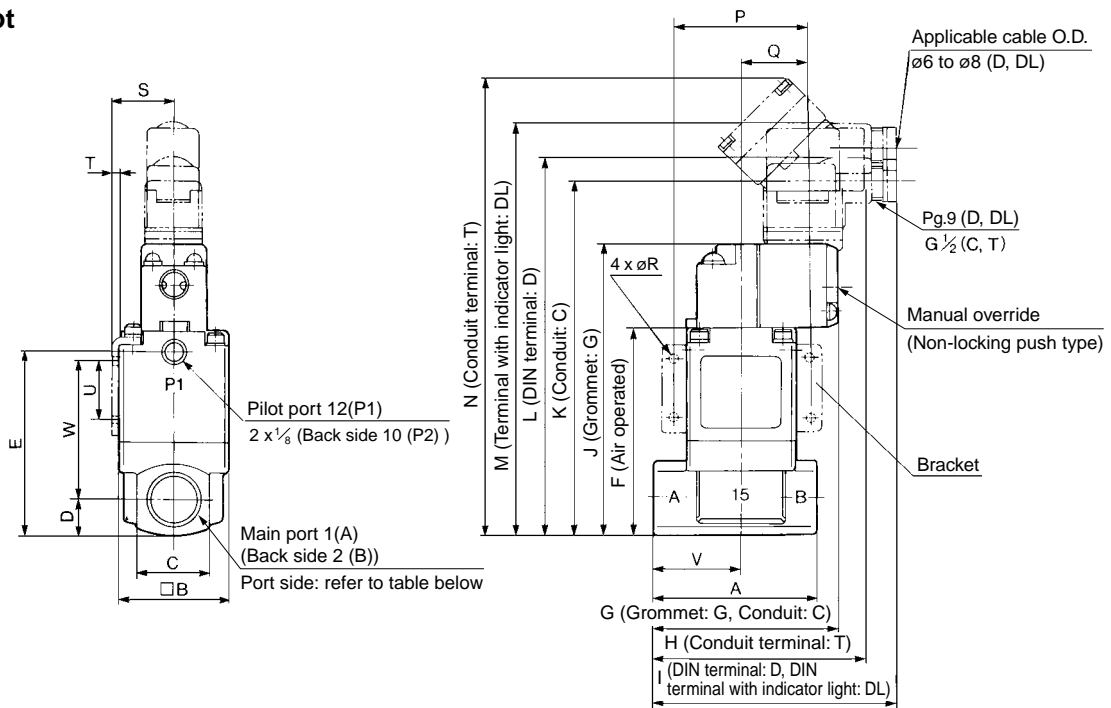

Model	Main port 1(A), 2(B)	A	B	C	D	E	F	G	H	I	J	K	L	M	N	P	Q	R	S	T	U	V	W
VNB2□□□V-10A	3/8	63	42	28	14	72.5	80.5	75	87	97	114	126.5	170.5	173.5	180.5	52	26	4.5	24.3	2.3	25	34	55
VNB2□□□V-15A	1/2	80	50	35	17.5	84	92	80	92	102	125.5	138	182	185	192	62	31	5.5	28.3	2.3	30	43	60.5
VNB3□□□V-20A	3/4	90	60	40	20	100	108	81	93	103	141.5	154	198	201	208	72	36	6.5	33.3	2.3	35	49	73
VNB4□□□V-25A	1																						

Port size: 32A, 40A, 50A

Standard/Vacuum pilot

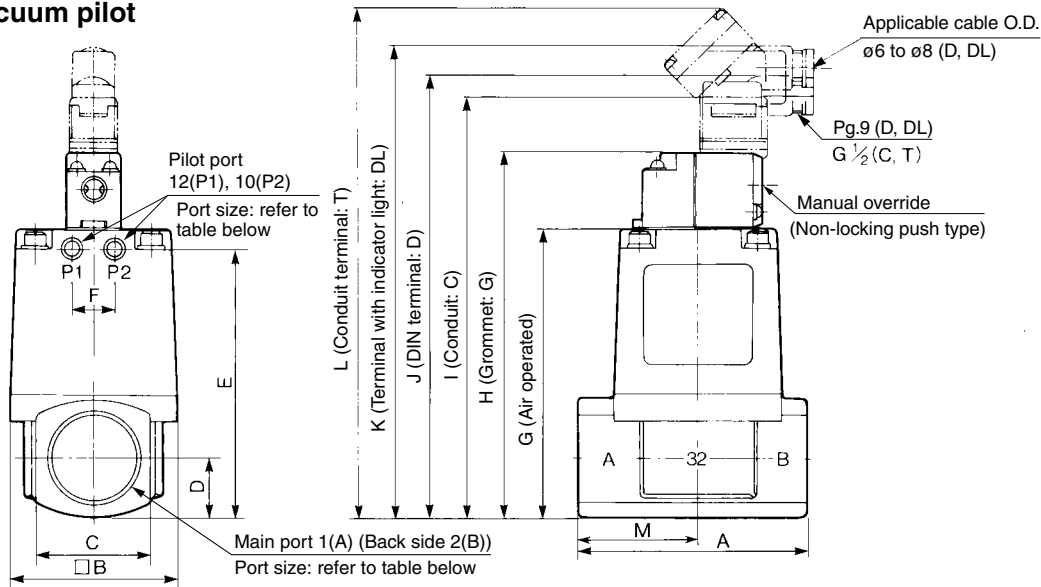

Model	Main port 1(A), 2(B)	Pilot port 12(P1), 10(P2)	A	B	C	D	E	F	G	H	I	J (Note)	K	L	M
VNB5□□□□-32A	1 1/4	1/8	105	77	53	26.5	120.5	20	129.5	163	175.5	218.5 (215.5)	223	229.5	55
VNB6□□□□-40A	1 1/2	1/4	120	96	60	30	137	24	147	180.5	193	236 (233)	240.5	247	63
VNB7□□□□-50A	2	1/4	140	113	74	37	160	24	170	203.5	216	259 (256)	263.5	270	74

Note) (): CE compliant product (-Q)

Port size: Flange: 32F, 40F, 50F

Standard/Vacuum pilot

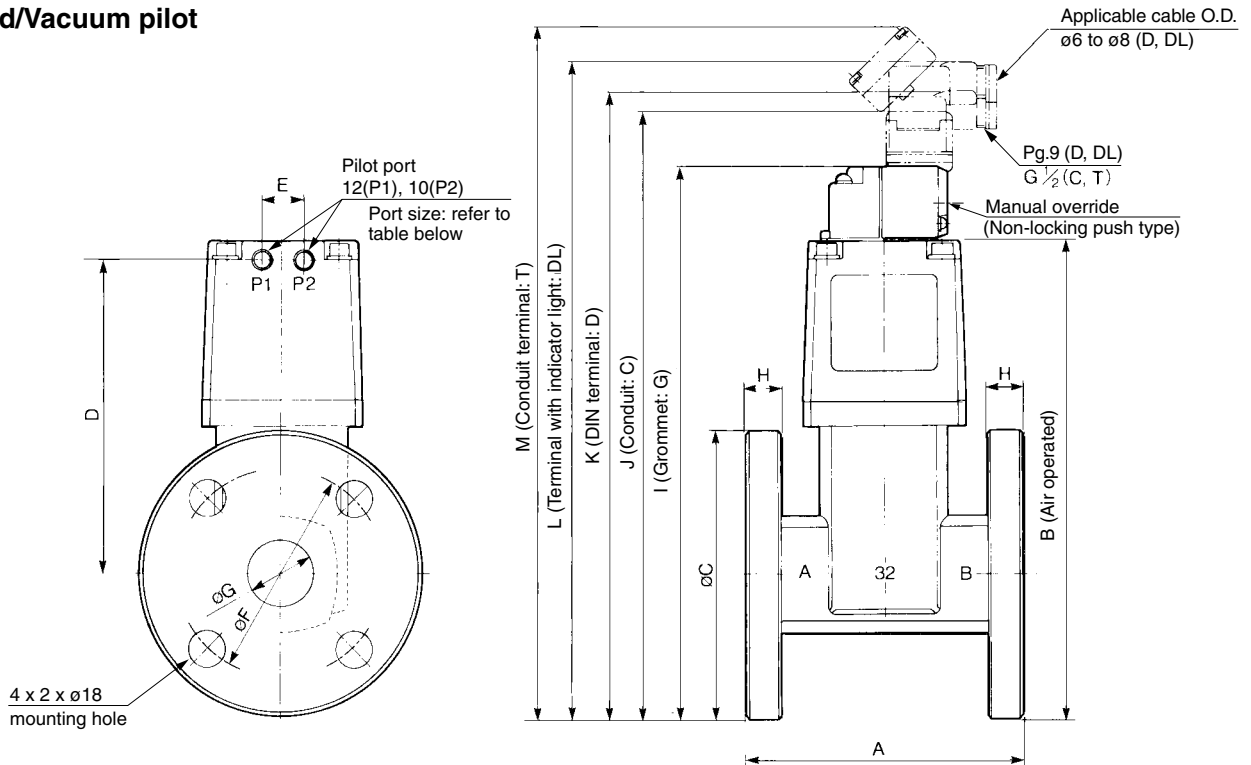

Model	Applicable flange 1(A), 2(B)	Pilot port 12(P1), 10(P2)	A	B	C	D	E	F	G	H	I	J	K (Note)	L	M
VNB5□□□□-32F	32	1/8	130	210.5	135	134	20	100	36	12	244	256.5	299.5 (296.5)	304	310.5
VNB6□□□□-40F	40	1/4	150	226	140	146	24	105	42	12	259.5	272	315 (312)	319.5	326
VNB7□□□□-50F	50	1/4	180	250	155	162.5	24	120	54	14	283.5	296	339 (336)	343.5	350

Note) (): CE compliant product (-Q)

VNA

VNB

SGC

VNC

VNH

VND

VCC



Series VNB Specific Product Precautions

Be sure to read before handling. Refer to front matters 42 and 43 for Safety Instructions, and pages 17 to 19 for 2 Port Solenoid Valves for Fluid Control Precautions.

External Pilot

⚠ Caution

Pilot port P1 and P2 piping

Please arrange P1 and P2 piping as follows according to the model.

Standard

Port	VNB□0 $\frac{1}{4}$ □	VNB□02□	VNB□03□	VNB□1 $\frac{1}{2}$ □
12 (P1)	External pilot	Bleed port	External pilot	External pilot
10 (P2)	Bleed port	External pilot	External pilot	Pilot exhaust

Vacuum pilot

Port	VNB□01□V	VNB□02□V	VNB□1 $\frac{1}{2}$ □V
12 (P1)	Bleed port	External pilot	External pilot
10 (P2)	External pilot	Bleed port	Pilot exhaust

Installing a silencer to the exhaust port and the bleed port is recommended for noise reduction and for dust entry prevention.

Piping

⚠ Caution

When high temperature fluids are used, use fittings and tube with heat resistant features.

(Self-align fittings, Teflon® tubing, Copper piping, etc.)

Mounting Direction of Pilot Solenoid Valve

⚠ Warning

With external pilot solenoids, the pilot solenoid valves are not splash proof specifications, and so care must be taken not to get fluid on oneself such as when performing maintenance.

⚠ Caution

Direction of mounting

When replacing a valve, if an external pilot solenoid valve is mounted in the wrong direction, it may malfunction or leak air.

Vacuum Pilot

⚠ Caution

When using the VNB□ $\frac{0}{1}$ □V N.C. vacuum pilot, maintain the specified pilot pressure by providing a tank with an appropriate capacity or by acquiring the pilot pressure from an area near the vacuum pump.

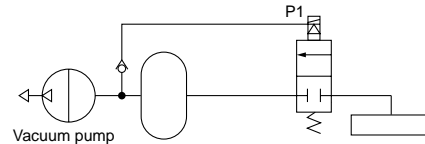

Coolant Valve

Series VNC

Air Operated/External Pilot Solenoid



Cylinder actuation by pilot air

Wide selection of port size and variations

Threaded type (6A to 50A)
Flange type (32F to 80F)



Low water hammer

For details, refer to page 407.

Large valve capacity

Av factor 30×10^{-6} to 1600×10^{-6}
(VNC1 to VNC7)
Cv factor 49 to 100
(VNC8 to VNC9)

VNA

VNB

SGC

VNC

VNH

VND

VCC

Coolant Valve: Air Operated/External Pilot Solenoid Series VNC



[Option]

Note) CE compliant: For D or DZ only

How to Order

Seal material

A	NBR seals
B	FKM seals

Thread type

Nil	Rc
F	G
N	NPT
T	NPTF

Bracket (Valve size: 1/2/3/4)

Nil	None
B ^{Note)}	With bracket (VN□-16)

Note) Only valve sizes 1, 2, 3 and 4. Shipped after assembled at our factory.
Bracket part no.
Valve size 1: VN1-A16 (with thread)
Valve sizes 2 to 4: VN□-16
↑ 2 to 4

Air operated VNC 2 0 1 A - [] 15A - [] (Except valve size 8, 9)

External pilot solenoid VNC 2 1 1 A - [] 15A - 1 T [] - [] - []

Valve size **Valve type** **Port size** **Rated voltage**

Symbol	Orifice diameter (mm)	Symbol			Symbol	Port size Rc
		1	2	4		
		N.C. 0.5 MPa	N.O. 1 MPa	N.C. 1 MPa		
1	ø7	—	●	●	6A	1/8
		—	●	●	8A	1/4
		—	●	●	10A	3/8
2	ø15 (ø11)	●	●	●	10A	3/8
3	ø20 (ø14)	●	●	●	15A	1/2
4	ø25 (ø16)	●	●	●	20A	3/4
		●	●	●	25A	1
		●	●	●	32A	1 1/4
5	ø32 (ø22)	●	●	●	32F	1 1/4 B Flange
6	ø40 (ø28)	●	●	●	40A	1 1/2
		●	●	●	40F	1 1/2 B Flange
		●	●	●	50A	2
7	ø50 (ø33)	●	●	●	50F	2B Flange
8	ø65 (ø45)	●	—	●	65F	2 1/2 B Flange
9	ø80 (ø56)	●	—	●	80F	3B Flange

Nil	Air operated
1	100 VAC 50/60 Hz
2	200 VAC 50/60 Hz
Note 2)3	110 VAC 50/60 Hz
Note 2)4	220 VAC 50/60 Hz
5	24 VDC
Note 2)6	12 VDC
Note 2)7	240 VAC 50/60 Hz
Note 2)9	Other

Note 1) Electrical entry: D or DZ only
Note 2) Semi-standard

CE compliant

Nil	—
Q	CE compliant

Note) Electrical entry: D or DZ only

Manual override

Nil: Non-locking push type	 A: Non-locking* push type A (projecting) B: Slotted locking type B* (tool required)	Valve size 1
Nil: Non-locking push type		
 * Semi-standard		Valve size 2 to 9

Electrical entry/With light/surge voltage suppressor

Symbol	Electrical entry	Valve size
G	Grommet	Valve size 1
GS	Grommet with surge voltage suppressor	
E	Grommet terminal	
EZ	Grommet terminal with light/surge voltage suppressor	
T	Conduit terminal	
TZ	Conduit terminal with light/surge voltage suppressor	
D	DIN terminal	
DZ	DIN terminal with light/surge voltage suppressor	
T	Conduit terminal	
TS	Conduit terminal with surge voltage suppressor	
Note 1)TZ	Conduit terminal with light/surge voltage suppressor	Valve size 2 to 9
Note 1)TL	Conduit terminal with indicator light	

CE compliant

D	DIN terminal*	Valve size
DZ	DIN terminal with light/surge voltage suppressor*	1 to 9

Note 1) Except rated voltage: 6, 7 and 9.
Note 2) For valve sizes 2 to 9 of the D DIN terminal and the DZ DIN terminal with light/surge voltage suppressor, be sure to add suffix -X200 at the end of the part number. (For CE compliant product, -X200 is not required.) In this case, the pilot solenoid valve is VO307-□□□.



Values in parentheses are N.C. at 1 MPa.

Coolant Valve: Air Operated/External Pilot Solenoid **Series VNC**



Model

Model	Port size		Orifice dia. ø (mm)	Flow characteristics		Mass (kg)	
	Threaded	(Note) Flange		Av x 10 ⁻⁶ m ²	Air operated	External pilot solenoid	
VNC1□□□-6A	1/8	—	7	30	0.2	0.3	
VNC1□□□-8A	1/4	—		32			
VNC1□□□-10A	—	—		36			
VNC2□4□-10A	3/8	—	11	95	0.5	0.7	
VNC2□□□-10A	—	—	15	120			
VNC2□4□-15A	1/2	—	11	110			
VNC2□□□-15A	—	—	15	140	0.8	1.0	
VNC3□4□-20A	3/4	—	14	170			
VNC3□□□-20A	—	—	20	260			
VNC4□4□-25A	1	—	16	220	1.2	1.4	
VNC4□□□-25A	—	—	25	370			
VNC5□4□-32A	1 1/4	—	22	400			
VNC5□□□-32A	—	—	32	560	2.2	2.4	
VNC5□4□-32F	—	32	22	400			
VNC5□□□-32F	—	—	32	560			
VNC6□4□-40A	1 1/2	—	28	630	3.6	3.8	
VNC6□□□-40A	—	—	40	820			
VNC6□4□-40F	—	—	28	720			
VNC6□□□-40F	—	40	40	960	6.8	7.0	
VNC7□4□-50A	2	—	33	990			
VNC7□□□-50A	—	—	50	1500			
VNC7□4□-50F	—	50	33	1000	10.2	10.4	
VNC7□□□-50F	—	—	50	1600			

Note) The companion flange is JIS B 2210 10K (standard) or its equivalent.

JIS Symbol

Valve type Operation	N.C.		N.O.	
	Air operated	VNC□0□□	VNC□02□	
External pilot solenoid	VNC□1□□	VNC□12□		

Model	Port size Flange (Note)	Orifice dia. ø (mm)	Flow characteristics		Mass (kg) External pilot solenoid
			Cv	Effective area (mm ²)	
VNC814□-65F	65	45	49	880	15.7
VNC811□-65F		65	70	1260	
VNC914□-80F	80	56	73	1400	21.2
VNC911□-80F		80	100	1800	

Note) The companion flange is JIS B 2210 10K (standard) or its equivalent.

Specifications

Fluid (Main piping)		Coolant (Note 2)
Fluid	VNC□□□A	-5 to 60°C (Note 1)
temperature	VNC□□□B	-5 to 99°C (Air operated type only) (Note 1)
Ambient temperature		-5 to 50°C (Air operated type: 60°C) (Note 1)
Proof pressure		1.5 MPa
Applicable pressure range	VNC□□1□	0 to 0.5 MPa
	VNC□□2□	0 to 1 MPa
External pilot air	Pressure	0.25 to 0.7 MPa
		0.1 + 0.25 x (Operating pressure) to 0.7 MPa Refer to "Graph (1)".
	Lubrication	Not required (Use turbine oil Class 1 ISO VG32, if lubricated.)
	Temperature	-5 to 50°C (Air operated type: 60°C) (Note 1)
Mounting orientation		Unrestricted (Note 3)

Note 1) No freezing
 Note 2) This product cannot be used in water.
 Note 3) For external pilot solenoid, it is recommended that the pilot solenoid valve be oriented either vertically upward or horizontally.

Graph (1) VNC□□2□ Pilot Pressure (N.O. type)

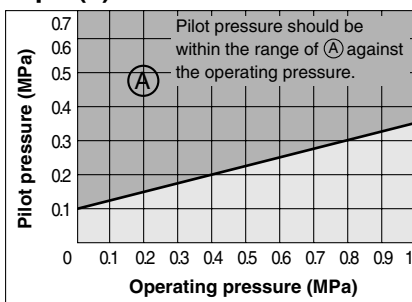

Pilot Solenoid Valve Specifications

Model	VNC1	VNC2 to 9	VNC2 to 9 (CE compliant)			
Pilot solenoid valve	SF4-□□□-23	VO301-00□□-X302	VO307-00□□□□-Q			
Electrical entry	Grommet	Conduit terminal	DIN terminal			
	Grommet terminal Conduit terminal DIN terminal					
Coil rated voltage (V)	AC (50/60 Hz)	100 V, 200 V, Other voltage (Option)				
	DC	24 V, Other voltage (Option)				
Allowable voltage fluctuation	-15% to +10% of rated voltage					
Temperature rise	35°C or less (when rated voltage is applied.)	70°C or less (when rated voltage is applied.)	50°C or less (when rated voltage is applied.)			
	Apparent power	AC	Inrush	5.6 VA (50 Hz) 5.0 VA (60 Hz)	12 VA (50 Hz) 10.5 VA (60 Hz)	12.7 VA (50 Hz) 10.7 VA (60 Hz)
			Holding	3.4 VA (50 Hz) 2.3 VA (60 Hz)	7.5 VA (50 Hz) 6 VA (60 Hz)	7.6 VA (50 Hz) 5.4 VA (60 Hz)
Power consumption	DC	1.8 W (without light), 2 W (with light)	4.8 W (without light), 5 W (with light)			
Manual override	Non-locking push type, Other (Option)		Non-locking push type			

Note) Refer to page 406 for how to order pilot solenoid valves.

VNA
VNB
SGC
VNC
VNH
VND
VCC

Construction

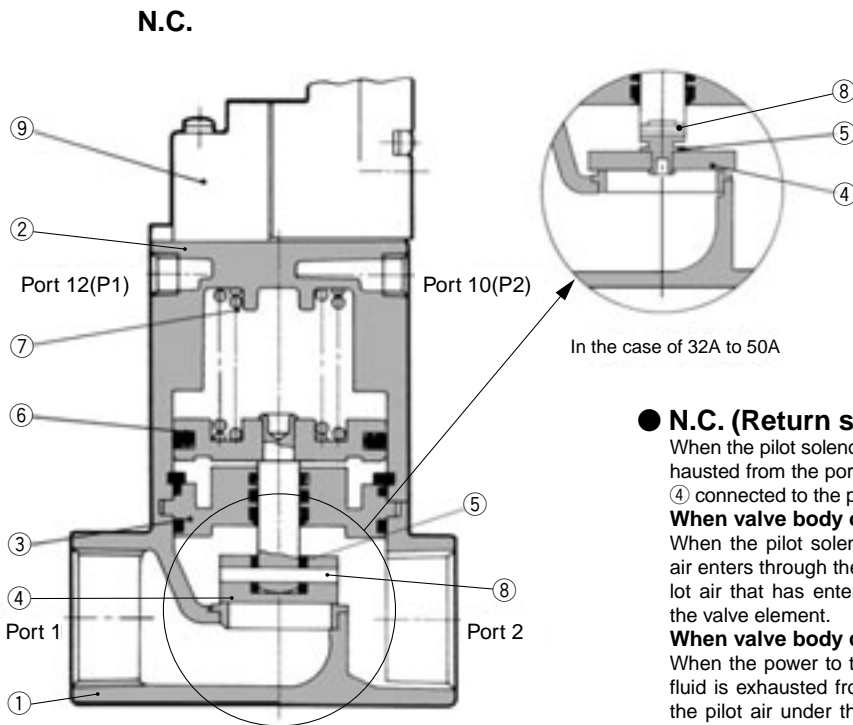

● N.C. (Return spring normally closed)

When the pilot solenoid valve ⑨ is not energized (or when air is exhausted from the port 12(P1) for air operated style), the valve body ④ connected to the piston ⑥ is closed by the return spring ⑦.

When valve body opens

When the pilot solenoid valve is energized (or when pressurized air enters through the port 12(P1) of the air operated style), the pilot air that has entered under the piston moves upward to open the valve element.

When valve body closes

When the power to the pilot solenoid valve is turned off (or when fluid is exhausted from the port 12(P1) of the air operated style), the pilot air under the piston is exhausted, and the return spring closes the valve element.

N.O.

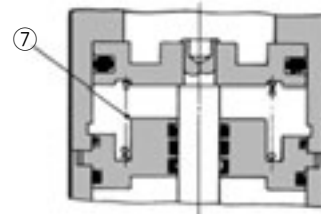

● N.O. (Return spring normally open)

In contrast with the N.C., when the pilot solenoid valve is not energized (or when air is exhausted from the port 10(P2) of the air operated style), the valve body is opened by the return spring. When the pilot solenoid valve is energized (or when pressurized air enters through the port 10(P2) of the air operated style), the valve body closes.

Component Parts

No.	Description	Material	Note
1	Body assembly	Cast iron	Plated
2	Cover assembly	Aluminum alloy	Platinum silver painted
3	Plate assembly	Iron	Valve composition, NBR, FKM
4	Valve element	Stainless steel	
5	Valve cover	NBR, FKM	32A to 50A are O-ring.
6	Piston assembly	Aluminum alloy	
7	Return spring	Piano wire	
8	Spiral pin	Stainless steel	
9	Pilot solenoid valve	—	

Note) 3, 5 components determine the valve composition.

Replacement Parts

No.	Description		Part no.							
			VNC1□□□ -6A, 8A, 10A	VNC2□□□ -10A, 15A	VNC3□□□ -20A	VNC4□□□ -25A	VNC5□□□ -32A, 32F	VNC6□□□ -40A, 40F	VNC7□□□ -50A, 50F	
3	Plate ass'y	Seal material	Refer to Note 1)	VN2-A3CA	VN3-A3CA	VN4-A3CA	VN5-A3CA	VN6-A3CA	VN7-A3CA	
		NBR FKM		VN2-A3CB	VN3-A3CB	VN4-A3CB	VN5-A3CB	VN6-A3CB	VN7-A3CB	
5	Valve cover (32A to 50A are O-ring.)	Seal material	Refer to Note 1)	VN2-12CA		VN4-12CA	AS568-010	AS568-011		AS568-012
		NBR FKM		VN2-12CB		VN4-12CB		AS568-011		AS568-012
8	Spiral pin			VN2-60-1	Refer to Note 2)	VN4-60-1	VN5-60-1	VN6-60-1	VN7-60-1	
9	Pilot solenoid valve		SF4-□□□-23	VO301-00□□-X302 (Refer to page 406 for part no.)						

Note 1) Request factory repair.

Note 2) For VNC3□₂□ use VN3-60-1, and for VNC3□4□ use VN2-60-1.

Replacement Parts: Applicable Flange

No.	Description		Part no.		
			VNC811□-65F	VNC911□-80F	
3	Plate assembly	Seal material	NBR	VN8-A3CA	VN9-A3CA
		FKM		VN8-A3CB	VN9-A3CB
8	Spiral pin		VN7-60-1		
9	Pilot solenoid valve		VO301-00□□-X302 (Refer to page 406 for part no.)		

Threaded Type/Port size: 6A, 8A, 10A

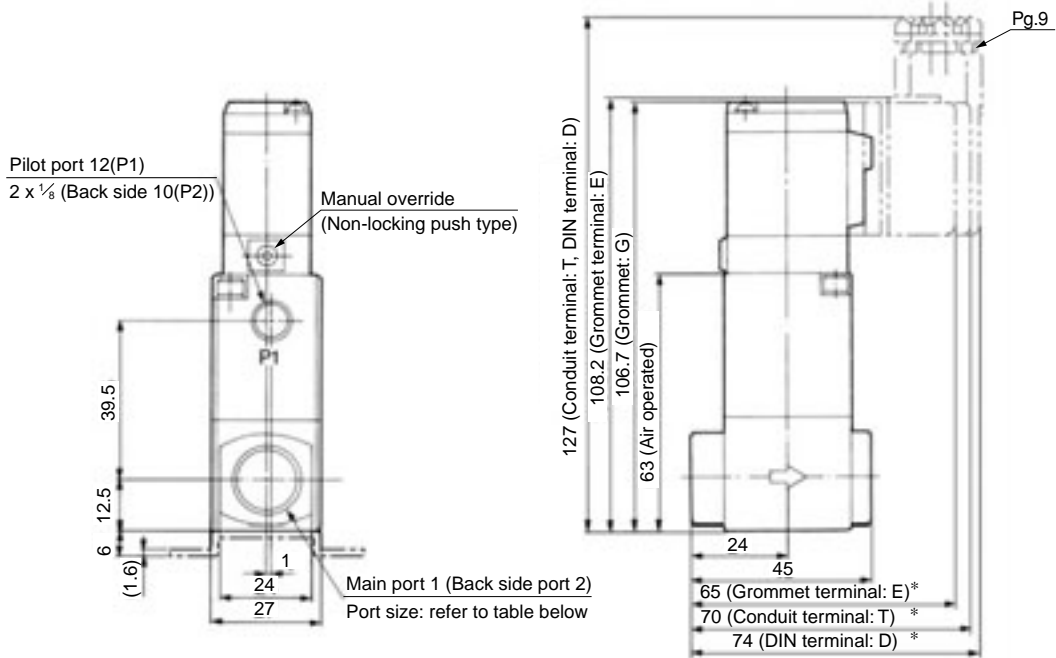

Model	Main port 1, 2
VNC1□□□-6A	1/8
VNC1□□□-8A	1/4
VNC1□□□-10A	3/8

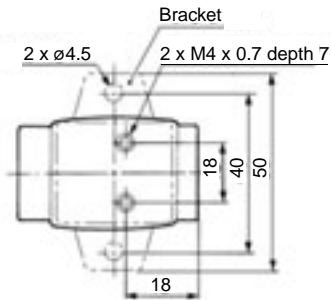

* In the case of "EZ" or "TZ" or "DZ", the length is longer by 9 mm.

VNA

VNB

SGC

VNC

VNH

VND

VCC

Series VNC

Threaded Type/Port size: 10A, 15A, 20A, 25A

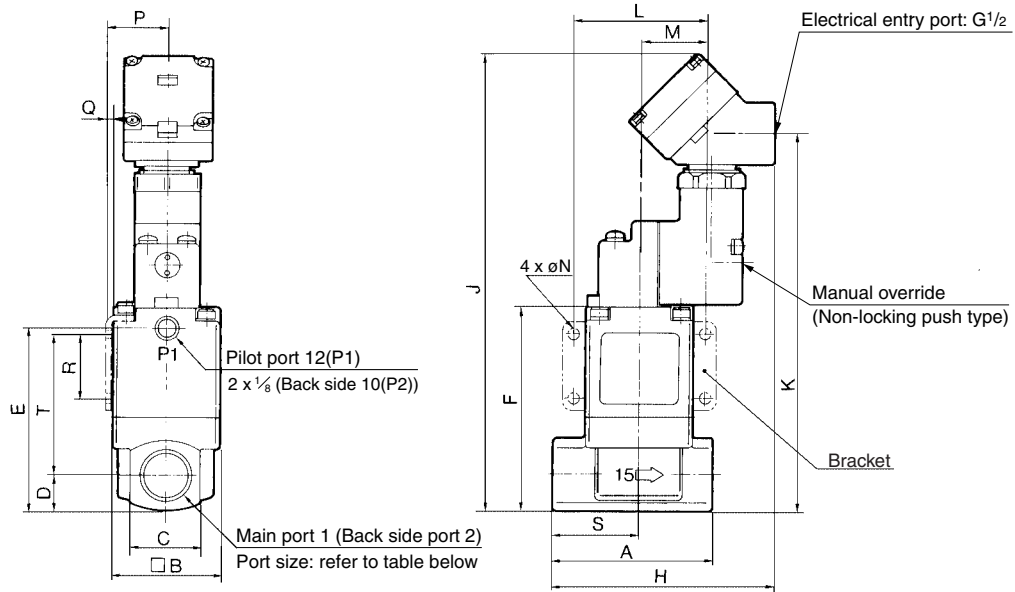

Model	Main port 1, 2	A	B	C	D	E	F	H	J (Note)	K	L	M	N	P	Q	R	S	T
VNC2□□□-10A	3/8	63	42	28	14	72.5	80.5	87	180.5 (166.5)	148	52	26	4.5	24.3	2.3	25	34	55
VNC2□□□-15A	1/2	63	42	28	14	72.5	80.5	87	180.5 (166.5)	148	52	26	4.5	24.3	2.3	25	34	55
VNC3□□□-20A	3/4	80	50	35	17.5	84	92	92	192 (178)	159.5	62	31	5.5	28.3	2.3	30	43	60.5
VNC4□□□-25A	1	90	60	40	20	100	108	93	208 (194)	175.5	72	36	6.5	33.3	2.3	35	49	73

Note) (): CE compliant product (-Q)

Threaded Type/Port size: 32A, 40A, 50A

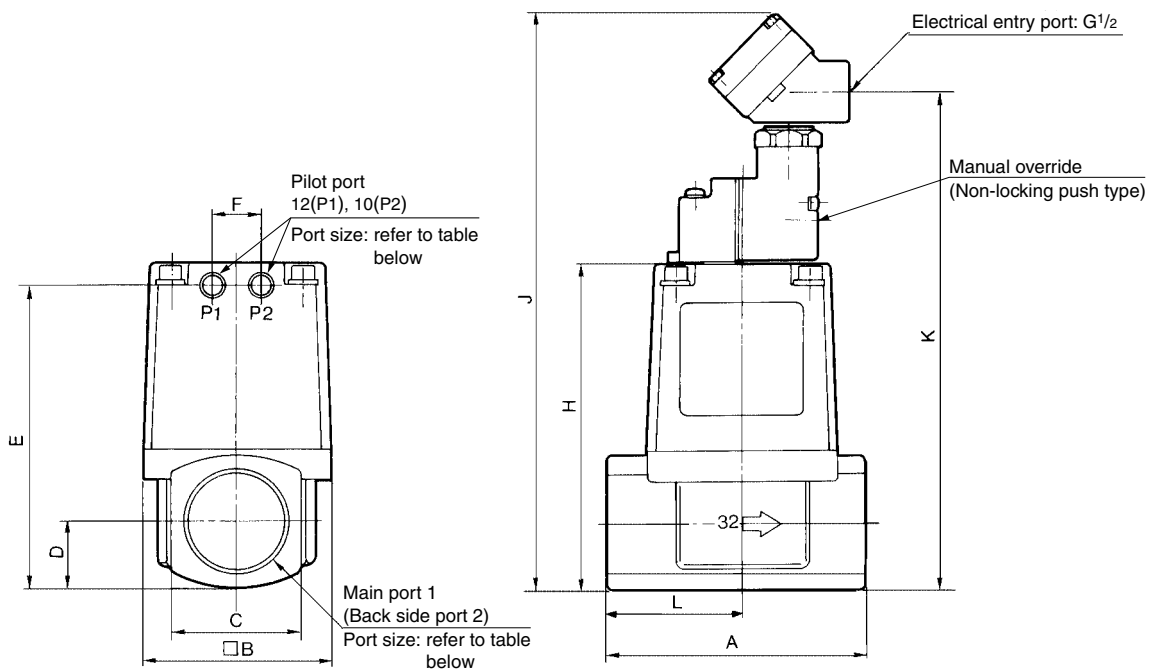

Model	Main port 1, 2	Pilot port 12(P1), 10(P2)	A	B	C	D	E	F	H	J (Note)	K	L
VNC5□□□-32A	1 1/4	1/8	105	77	53	26.5	120.5	20	129.5	229.5 (215.5)	197	55
VNC6□□□-40A	1 1/2	1/4	120	96	60	30	137	24	147	247 (233)	214.5	63
VNC7□□□-50A	2	1/4	140	113	74	37	160	24	170	270 (256)	237.5	74

Note) (): CE compliant product (-Q)

Coolant Valve: Air Operated/External Pilot Solenoid **Series VNC**

Flange Type/Port size: 32F, 40F, 50F

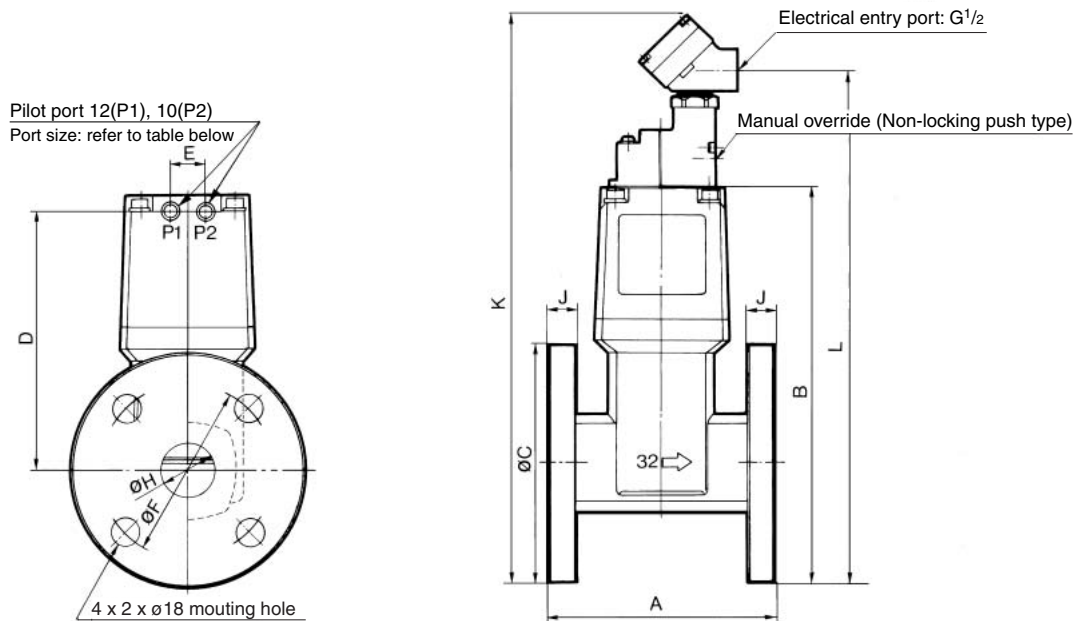

Model	Applicable flange Port 1, 2	Pilot port 12(P1), 10(P2)	A	B	C	D	E	F	H	J	K Note)	L
VNC5□□□-32F	32	1/8	130	210.5	135	134	20	100	36	12	310.5 (296.5)	278
VNC6□□□-40F	40	1/4	150	226	140	146	24	105	42	12	326 (312)	293.5
VNC7□□□-50F	50	1/4	180	250	155	162.5	24	120	54	14	350 (336)	317.5

Note) (): CE compliant product (-Q)

Flange Type/Port size: 65F, 80F

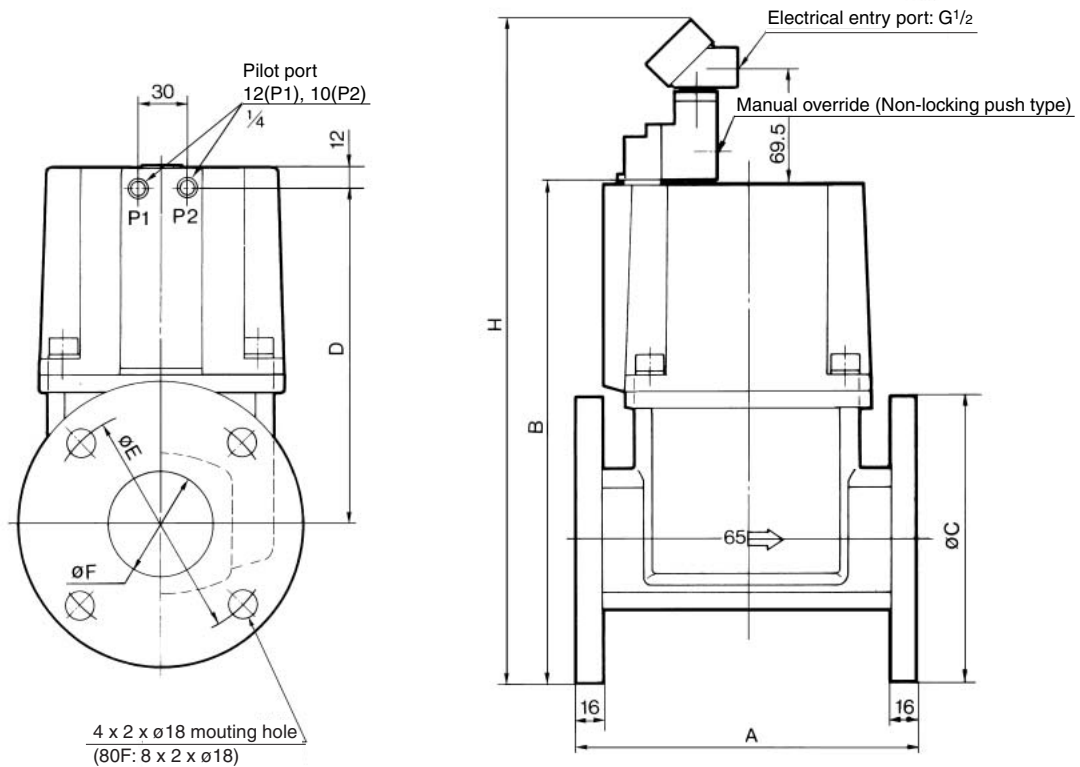

Model	Applicable flange Port 1, 2	A	B	C	D	E	F	H Note)
VNC81¼□-65F	65	210	305.5	175	204	140	65	405.5 (391.5)
VNC91¼□-80F	80	240	341.5	185	235	150	80	441.5 (427.5)

Note) (): CE compliant product (-Q)

VNA

VNB

SGC

VNC

VNH

VND

VCC

Series VNC

How to Order Pilot Solenoid Valves

Valve size 1

SF4 - 5 D [] - 23 - Q

SF4 - 5 D [] - 23

CE compliant
* Electrical entry:
D or DZ only

Coil rated voltage

1	100 VAC 50/60 Hz
2	200 VAC 50/60 Hz
3*	110 VAC 50/60 Hz
4*	220 VAC 50/60 Hz
5	24 VDC
6*	12 VDC
7*	240 VAC 50/60 Hz
9*	Other

* Semi-standard

Manual override

Nil	Non-locking push type
A*	Non-locking push type A (projecting)
B*	Slotted locking type B (tool required)

* Semi-standard

Electrical entry/

With light/surge voltage suppressor		CE compliant
G	Grommet	—
GS	Grommet with surge voltage suppressor	—
E	Grommet terminal	—
EZ	Grommet terminal with light/surge voltage suppressor	—
T	Conduit terminal	—
TZ	Conduit terminal with light/surge voltage suppressor	—
D	DIN terminal	●
DZ	DIN terminal with light/surge voltage suppressor	●

Valve size 2 to 9

VO307 - [] [] - Q

VO301 - 00 [] [] - X302

CE compliant
Note 1) Electrical entry: D or DZ only

Coil rated voltage

1	100 VAC 50/60 Hz
2	200 VAC 50/60 Hz
3*	110 VAC 50/60 Hz
4*	220 VAC 50/60 Hz
5	24 VDC
6*	12 VDC
7*	240 VAC 50/60 Hz
9*	Other

* Semi-standard

Light/surge voltage suppressor

		CE compliant
T	Conduit terminal	—
TS	Conduit terminal with surge voltage suppressor	—
Note 1) TZ	Conduit terminal with light/surge voltage suppressor	—
Note 1) TL	Conduit terminal with indicator light	—
D	DIN terminal	●
Note 2) DZ	DIN terminal with light/surge voltage suppressor*	●

Note 1) Except rated voltage: 6, 7 and 9.

Note 2) VO307 only

Accessory

Function plate for VO301 (D seal, with thread): DXT060-32-4A

Function plate for VO307 (D seal, with thread): DXT152-14-1A



Series VNC

Specific Product Precautions

Be sure to read this before handling.

Refer to front matters 42 and 43 for Safety Instructions, and pages 17 to 19 for 2 Port Solenoid Valves for Fluid Control Precautions.

External Pilot

⚠ Caution

Pilot port 12(P1) and 10(P2) piping
P1 and P2 piping should be as follows according to the model.

Port	Air operated		Solenoid
	VNC□□1□	VNC□□2□	VNC□□1½□
12 (P1)	External pilot	Bleed port	External pilot
10 (P2)	Bleed port	External pilot	Pilot exhaust

Installing a silencer to the exhaust port and the bleed port is recommended for noise reduction and for dust entry prevention.

Piping

⚠ Caution

When high temperature fluids are used, use fittings and tube with heat resistant features. (Self-align fittings, Teflon® tubing, Copper piping, etc.)

Pilot Solenoid Valve

⚠ Warning

With external pilot solenoids, the pilot solenoid valves are not splash proof specifications, and so care must be taken not to get fluid on oneself such as when performing maintenance.

⚠ Caution

Direction of mounting

When replacing a valve, if an external pilot solenoid valve is mounted in the wrong direction, it may malfunction or leak air.

Water Hammer Characteristics

VNC□□1□ (N.C. 0.49 MPa) Conditions: Piping 30 m
Steel tube, total pressure 0.49 MPa

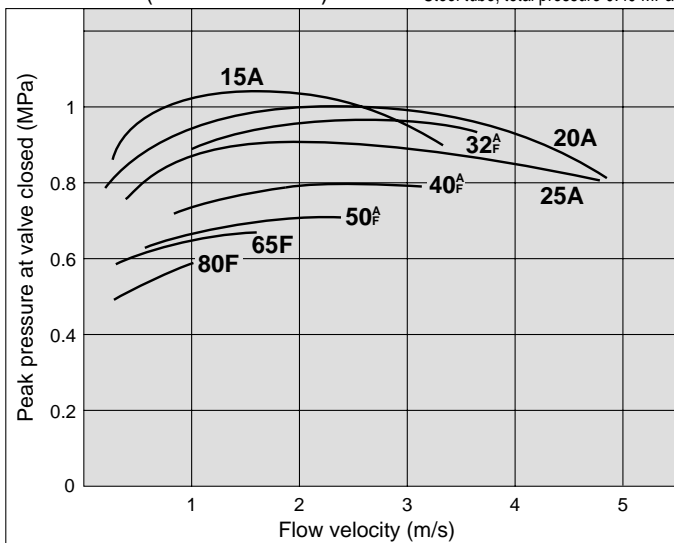

VNC□□4□ (N.C. 0.97 MPa) Conditions: Piping 30 m
Steel tube, total pressure 0.97 MPa

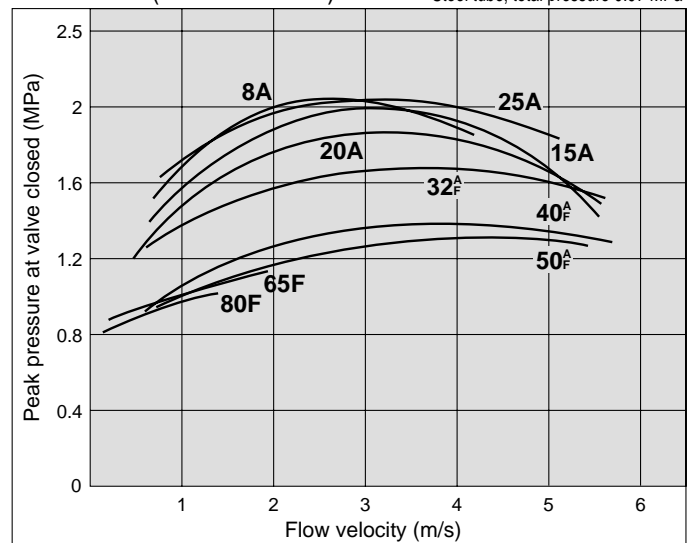

Calculating the Flow Velocity

$$v = 21.2 \times Q/d^2$$

(Symbol)

v: flow velocity (m/s)

Q: flow rate (l/min)

d: piping inner diameter (mm)

VNA

VNB

SGC

VNC

VNH

VND

VCC

High Pressure Coolant Valve

Series VNH

3.5 MPa, 7.0 MPa



Corresponding to high speed grinding and long drilling processes

Valve for high pressure coolant liquid (up to 3.5 MPa or 7.0 MPa) that is ideal for lubrication, dust blowing and cooling.

Valve for coolant

Pilot air operated cylinder driving mechanism. Metal seal with poppet valve structure.

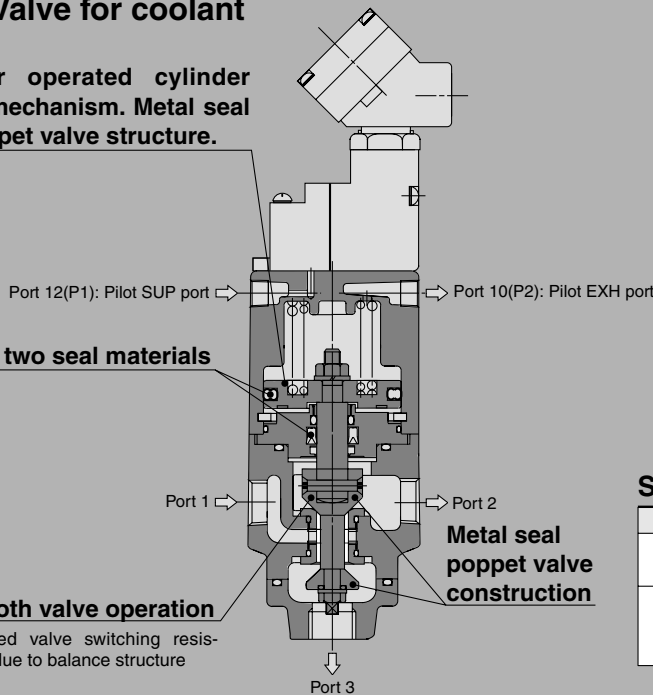

Choice of two seal materials
NBR/FKM

Smooth valve operation
Reduced valve switching resistance due to balance structure



Series

Operating fluid pressure	Port	Port size Rc
3.5 MPa	3 Port	3/8(10A), 1/2(15A)
		3/4(20A), 1(25A)
7.0 MPa	2 port (Large flow type)	3/8(10A), 1/2(15A)
	3 Port	3/4(20A), 1(25A)

Application Example

3 port valve (3.5 MPa, 7.0 MPa)

Ex. 1) 3 port valve: Reducing load to pump

Piping

Inlet side (supply side): port 1, Outlet side (exhaust side): port 2 and port 3. Supply pilot air higher than 0.25 MPa to port 12(P1).

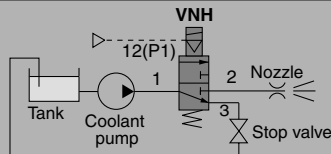

For reducing load to pump, coolant liquid is returned from B port to tank each time.

Ex. 2) 3 port valve: Switching nozzle

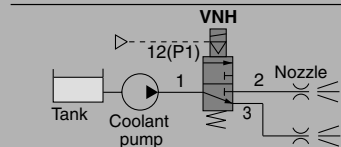

Switching nozzles on supplying coolant liquid.

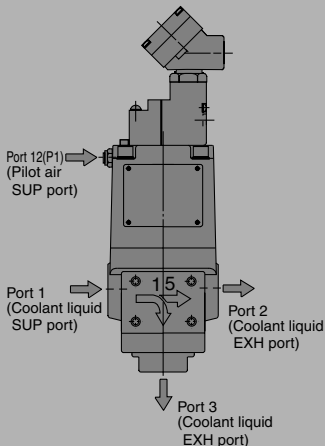

2 port valve (7.0 MPa)

Ex. 1) 2 port valve: Nozzle ON/OFF

Piping

Inlet side (supply side): port 1, Outlet side (exhaust side): port 2. Supply pilot air higher than 0.25 MPa to port 12(P1).

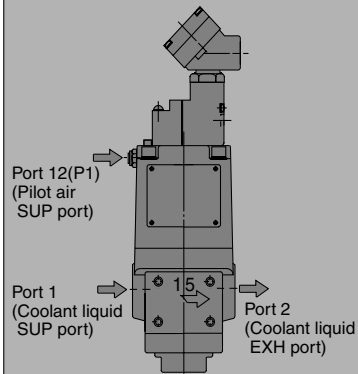
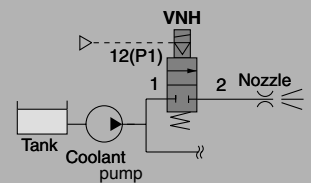

- VNA
- VNB
- SGC
- VNC
- VNH**
- VND
- VCC

High Pressure Coolant Valve: 3.5 MPa, 7.0 MPa

Series VNH



[Option]

Note) Electrical entry: D or DZ only

How to Order

Air operated

External pilot solenoid

VNH **2** **1** **1** **A** - **15A** -

VNH **2** **1** **1** **A** - **15A** - **1** **T** -

Note) Silencer is provided as standard on pilot EXH port (P2).

Port

1	3 port
3*	2 port

* 2 port is 7.0 MPa only.

Valve type

1	N.C./3.5 MPa
3	N.C./7.0 MPa

Thread type

Nil	Rc
F	G
N	NPT
T	NPTF

Seal material

A	NBR seals
B	FKM seals

Valve size **Port size**

1	10A	3/8
2	15A	1/2
3	20A	3/4
4	25A	1

CE compliant

Nil	—
Q	CE compliant*

Note) Electrical entry: D or DZ only

Option

Nil	None
B	With bracket

Electrical entry/With light/surge voltage suppressor

T	Conduit terminal
TS	Conduit terminal with surge voltage suppressor
TZ ^{Note 1)}	Conduit terminal with light/surge voltage suppressor
TL ^{Note 1)}	Conduit terminal with indicator light

CE compliant

D	DIN terminal
DZ	DIN terminal with light/surge voltage suppressor

Note 1) Rated voltage: Except 6, 7, 9.
Note 2) For the D DIN terminal and the DZ DIN terminal with light/surge voltage suppressor, be sure to add suffix -X200 at the end of the part number. (For CE compliant product, -X200 is not required.) In this case, the pilot solenoid valve is VO307-□D□.

Option

Description	Component part no.	Component part no.			
		VNH1□□	VNH2□□	VNH3□□	VNH4□□
Bracket (With bolt and washer)	B	VNH1-16	VNH2-16	VNH3-16	VNH4-16

Rated voltage

1	100 VAC 50/60 Hz
2	200 VAC 50/60 Hz
3 ^{Note 2)}	110 VAC 50/60 Hz
4 ^{Note 2)}	220 VAC 50/60 Hz
5	24 VDC
6 ^{Note 2)}	12 VDC
7 ^{Note 2)}	240 VAC 50/60 Hz
9 ^{Note 2)}	Other

Note 1) Electrical entry: D or DZ only

Note 2) Semi-standard

How to Order Pilot Solenoid Valves

VO307-□□ - **Q** **CE compliant**
Note) Electrical entry: D or DZ only

VO301-00 □□ - **X302**

Rated voltage

1	100 VAC 50/60 Hz
2	200 VAC 50/60 Hz
3*	110 VAC 50/60 Hz
4*	220 VAC 50/60 Hz
5	24 VDC
6*	12 VDC
7*	240 VAC 50/60 Hz
9*	Other

* Semi-standard

Light/surge voltage suppressor

		CE compliant
T	Conduit terminal	—
TS	Conduit terminal with surge voltage suppressor	—
TZ ^{Note 1)}	Conduit terminal with light/surge voltage suppressor	—
TL ^{Note 1)}	Conduit terminal with indicator light	—
D	DIN terminal	●
DZ ^{Note 2)}	DIN terminal with light/surge voltage suppressor*	●

Note 1) Except rated voltage 6, 7, 9

Note 2) VO307 only

Accessory

Function plate for VO301 (D sealing, with thread): DXT060-32-4A

Function plate for VO307 (D sealing, with thread): DXT152-14-1A

High Pressure Coolant Valve *Series VNH*

3.5 MPa, 7.0 MPa

Specifications

Model	3 port valve								2 port valve			
	VNH111 ^A _B -10A	VNH211 ^A _B -15A	VNH311 ^A _B -20A	VNH411 ^A _B -25A	VNH113 ^A _B -10A	VNH213 ^A _B -15A	VNH313 ^A _B -20A	VNH413 ^A _B -25A	VNH133 ^A _B -10A	VNH233 ^A _B -15A	VNH333 ^A _B -20A	VNH433 ^A _B -25A
Operating fluid pressure	0 to 3.5 MPa								0 to 7.0 MPa			
Fluid (Main piping)	Coolant ^{Note 2)}											
Operation	External pilot solenoid/Air operated											
Operating fluid temperature	-5 to 60°C ^{Note 1)} /-5 to 60°C ^{Note 1)} (NBR seal)											
	-5 to 60°C ^{Note 1)} /-5 to 99°C ^{Note 1)} (FKM seal)											
Pilot air	Pressure											
	0.25 to 0.7 MPa											
	Temperature											
-5 to 50°C ^{Note 1)}												
Lubrication												
Not required (Use turbine oil Class 1 ISO VG32, if lubricated.)												
Proof pressure	5.5 MPa								10.5 MPa			
Ambient temperature	-5 to 50°C ^{Note 1)}											
Max. operating frequency	20 times/min											
Mounting position	Vertical upwards											
Port size	3/8	1/2	3/4	1	3/8	1/2	3/4	1	3/8	1/2	3/4	1
Orifice diameter (mm)	ø7.1 *	ø8.7 *	ø10.6 *	ø14.3 *	ø3.9 *	ø5.2 *	ø6.2 *	ø7.3 *	ø8	ø9.5	ø13	ø15.7
Flow characteristics Av x 10 ⁻⁶ m ²	46	86	110	190	15	29	38	58	54	75	140	210
Pilot port size	1/8			1/4				1/8			1/4	
Mass (kg)	2	3.1	5.6	8.2	2	3.1	5.6	8.2	2	3.1	5.6	8.2
Face-to-face dimension (mm)	60	80	100	115	60	80	100	115	60	80	100	115



* Equivalent size

Note 1) No freezing

Note 2) This product cannot be used for water applications.



Pilot Operated Solenoid Valve Specifications

Pilot solenoid valve		VO301-00□□-X302	VO307-00□□ ^{Bz} -Q
Electrical entry		Conduit terminal	DIN terminal
Coil rated voltage (V)	AC (50/60 Hz)	100 V, 200 V, Other voltage (Option)	
	DC	24 V, Other voltage (Option)	
Allowable voltage fluctuation		-15 to +10% of the rated voltage	
Temperature rise		70°C or less (When rated voltage is applied.)	50°C or less (When rated voltage is applied.)
Apparent power	AC	Inrush	12 VA (50 Hz), 10.5 VA (60 Hz)
		Holding	7.5 VA (50 Hz), 6 VA (60 Hz)
Power consumption	DC	4.8 W (without light), 5.0 W (with light)	
Manual override		Non-locking push type	

Note) Refer to page 412 for how to order pilot solenoid valves.

JIS Symbol

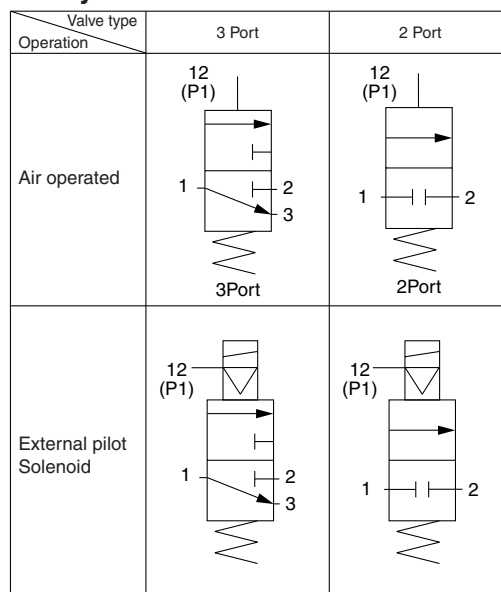

VNA

VNB

SGC

VNC

VNH

VND

VCC

Dimensions

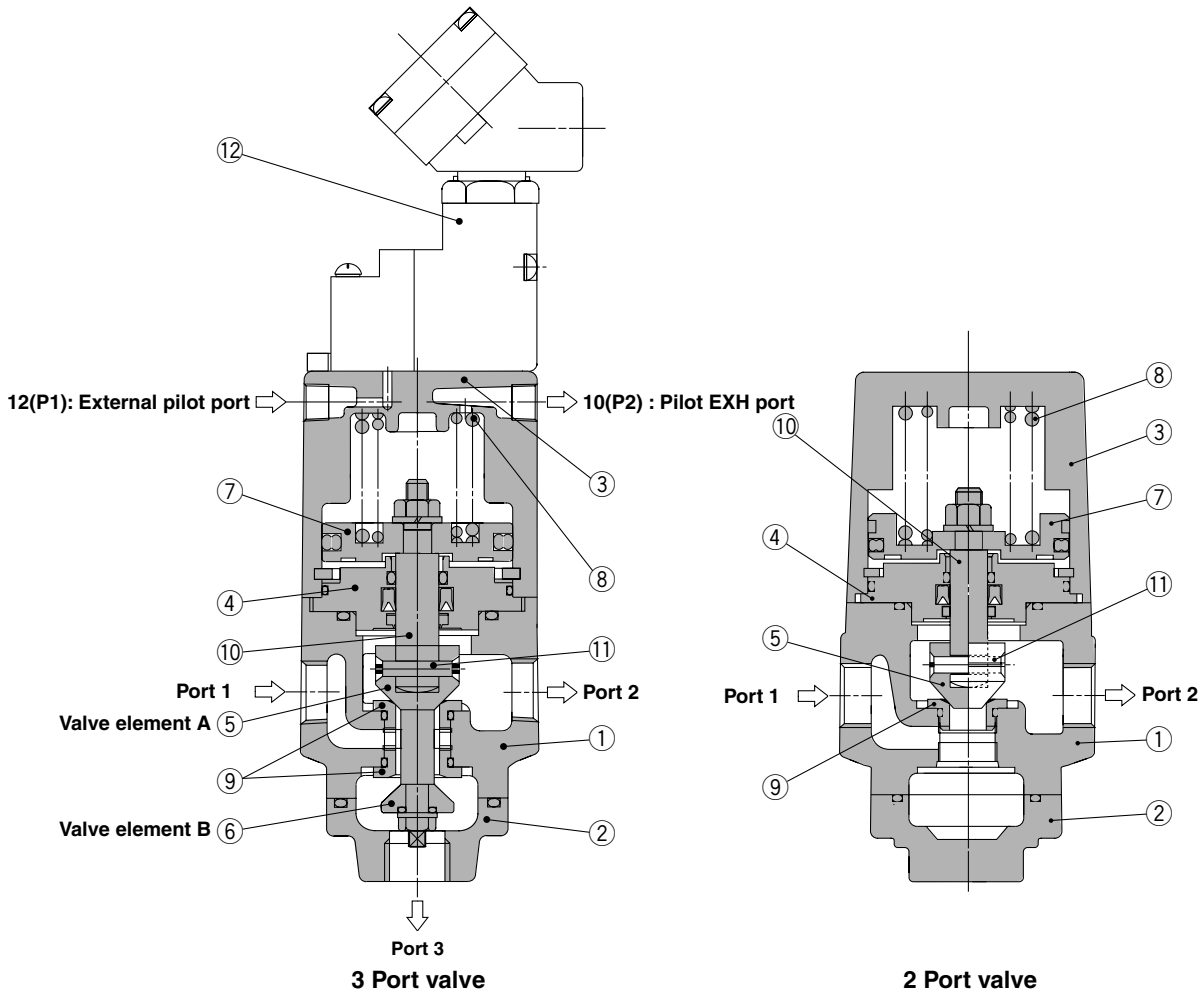

Working Principle

When the pilot operated solenoid valve ⑫ is not energized, the valve element A ⑤ connected to the piston ⑦ is closed by the return spring ⑧. Then valve element B ⑥ connected to the valve element A ⑤ is open. When the pilot operated solenoid valve ⑫ is energized (or when pressurized air enters through the port 12(P1) of the air operated style), the pilot air supplied to the bottom of the piston ⑦ moves upward to open the valve element A ⑤ and closes the valve element B ⑥.

Component Parts

No.	Description	Material	Note
1	Body	Cast iron	Plated
2	Undercover	Cast iron	Plated
3	Cover	Aluminum alloy	
4	Plate	Iron	
5	Valve element A	Stainless steel	
6	Valve element B	Stainless steel	
7	Piston	Aluminum alloy	
8	Return spring	Piano wire	
9	Valve seat	Stainless steel	
10	Rod	Stainless steel	
11	Parallel pin	Stainless steel	
12	Pilot solenoid valve	Refer to "How to Order Pilot Solenoid Valves" on the right.	

How to Order Pilot Solenoid Valves

VO307-00 - Q CE compliant

VO301-00 - X302

Coil rated voltage

1	100 VAC 50/60 Hz
2	200 VAC 50/60 Hz
3*	110 VAC 50/60 Hz
4*	220 VAC 50/60 Hz
5	24 VDC
6*	12 VDC
7*	240 VAC 50/60 Hz
9*	Other

* Semi-standard

Light/surge voltage suppressor

		CE compliant
T	Conduit terminal	—
TS	Conduit terminal with surge voltage suppressor	—
TZ ^{Note)}	Conduit terminal with light/surge voltage suppressor	—
TL ^{Note)}	Conduit terminal with indicator light	—
D	DIN terminal*	●
DZ	DIN terminal with light/surge voltage suppressor*	●

Note) Except 12 VDC, 240 VAC, other voltages.

* CE compliant products only

Accessory

Function plate for VO301 (D seal, with thread): DXT060-32-4A

Function plate for VO307 (D seal, with thread): DXT152-14-1A

Dimensions

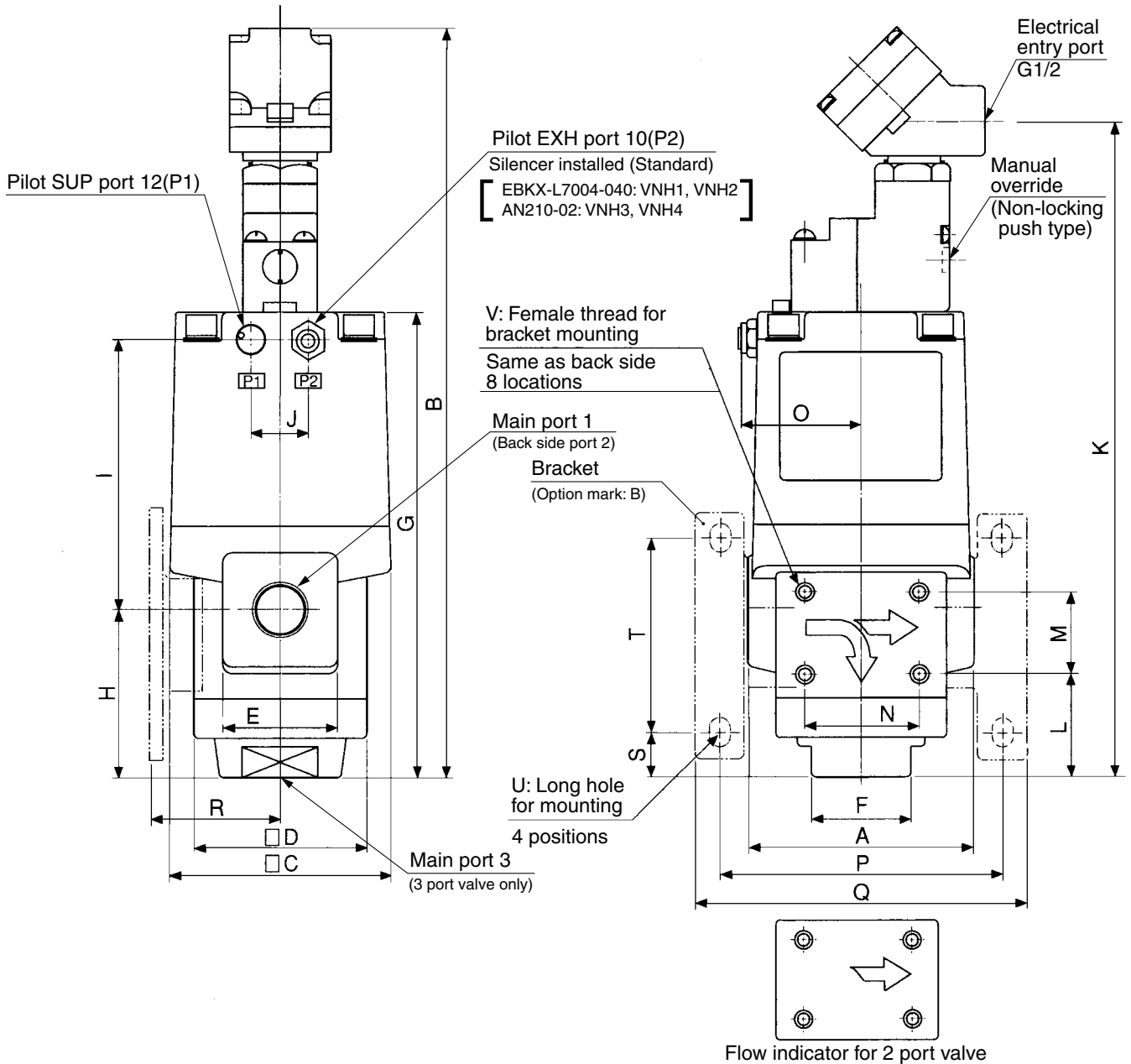

Dimensions

(mm)

Model	Main port 1, 2, 3		Pilot port 12(P1), 10(P2)	A	B (Note)	C	D	E	F	G	H	I
	2 Port	3 Port										
VNH1□□ _A ¹⁰ -10A	2 x 3/8	3 x 3/8	1/8	60	235 (221)	60	46	34	24	135	50	77
VNH2□□ _A ¹⁵ -15A	2 x 1/2	3 x 1/2	1/8	80	264.5 (250.5)	77	60	40	36	164.5	60	95.5
VNH3□□ _A ²⁰ -20A	2 x 3/4	3 x 3/4	1/4	100	300 (286)	96	76	50	41	200	79	111
VNH4□□ _A ²⁵ -25A	2 x 1	3 x 1	1/4	115	319 (305)	113	85	60	50	219	90	119

Note) (): CE compliant product (-Q)

Model	J	K	L	M	N	O	P	Q	R	S	T	U	V
VNH1□□ _A ¹⁰ -10A	-	202.5	29	25	30	37	75	88	34	10.5	62	6 x 8	M5 x 0.8 depth 5.5
VNH2□□ _A ¹⁵ -15A	20	232	36	30	40	43	100	118	44.5	16	70	7 x 10	M6 x 1 depth 6
VNH3□□ _A ²⁰ -20A	24	267	48	35	50	50.5	126	148	60.5	19.5	92	9 x 12	M8 x 1.25 depth 6
VNH4□□ _A ²⁵ -25A	24	286.5	51	38	56	58.5	141	163	66.5	15.5	109	9 x 12	M8 x 1.25 depth 6

VNA

VNB

SGC

VNC

VNH

VND

VCC



Series VNH

Specific Product Precautions

Be sure to read before handling.

Refer to front matters 42 and 43 for Safety Instructions, and pages 17 to 19 for 2 Port Solenoid Valves for Fluid Control Precautions.

Back Pressure of 3 Port Valve (VNH□13)

Caution

1. Ensure that back pressure of 3 port from VNH□13 is less than 5 MPa.

Quality of Operating Fluid

Caution

Please note that using fluids that contain foreign material (especially hard objects like glass chips), may cause damage to the valve, will reduce sealing performance, and may cause early failure.

Piping

Caution

When high temperature fluids are used, use fittings and tubing with heat resistant features. (Self-align fittings, Teflon[®] tubing, Copper tubing, etc.)

Pilot Solenoid Valve

Warning

With external pilot solenoids, the pilot solenoid valves are not splash proof specifications, and so care must be taken not to get fluid on oneself such as when performing maintenance.

Caution

Direction of mounting

When replacing a valve, if an external pilot solenoid valve is mounted in the wrong direction, it may malfunction or leak air.