

# 19 Raised design

## Indicator, IP 40

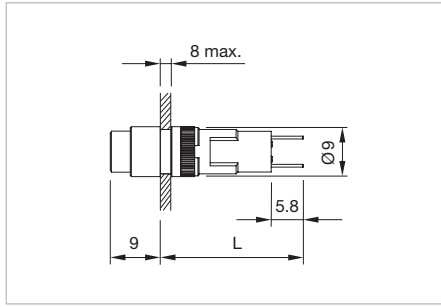

Product can differ from the current configuration.



Dimensions [mm]

### Additional Information

- For LED element fitting information see «Application guidelines»

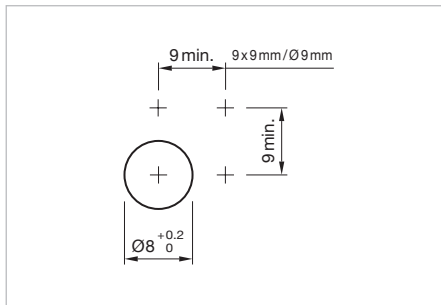

Mounting cut-outs [mm]

### Equipment consisting of (schematic overview)



**Lens** page 7



**Single-LED** page 10





**Actuator**



**Fixing nut**

Each Part Number listed below includes all the black components shown in the 3D-drawing.

*To obtain a complete unit, please select the red components from the pages shown.*

Behind panel depth	Terminal	Part No.	Component layout	Wiring diagram	Weight
 <p><b>Indicator actuator, Front dimension 9 x 9 mm</b></p>					
25 mm	Solder 2.0 x 0.5mm	<b>19-050.005</b>	1	1	0.001 kg
33 mm	Solder 2.0 x 0.5mm	<b>19-051.005</b>	1	1	0.002 kg
 <p><b>Indicator actuator, Front dimension Ø 9 mm</b></p>					
25 mm	Solder 2.0 x 0.5mm	<b>19-030.005</b>	1	1	0.001 kg
33 mm	Solder 2.0 x 0.5mm	<b>19-031.005</b>	1	1	0.002 kg

The component layouts you will find from page 14

