

NOTE:

⚠ WIRE RANGE: 255-1855 CMA (0.13-0.93 mm<sup>2</sup>)  
 MEANS 26-18 AWG (0.13-0.82 mm<sup>2</sup>)  
 STRANDED WIRE IN COMBINATION WITH  
 40-26 AWG MAGNET WIRE.  
 USING TINNED LEAD WIRE:  
 WIRE RANGE: 255-1855 CMA (0.13-0.93 mm<sup>2</sup>)  
 USING COPPER LEAD WIRE:  
 WIRE RANGE: 1250-1855 CMA (0.63-0.93 mm<sup>2</sup>)

⚠ DIRECTION OFF TOP OF REEL

⚠	160 631-6	BRASS	PRE-TINNED
⚠	160 631-5	BRASS	PRE-TINNED
⚠	160 631-3	BRASS	PRE-TINNED
	ORDER NO.	MATERIAL	PLATING

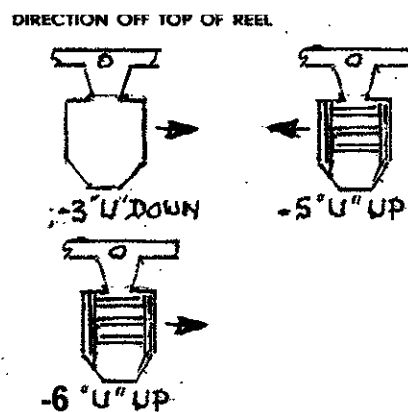

NUMBER 160631

DR. <i>H. J. van Chaster</i> DATE 14.11.1973		© 1973 BY AMP-HOLLAND N.V. ALL RIGHTS RESERVED A-MP PRODUCTS COVERED BY PATENTS AND/OR PATENTS PENDING.		 AMP-HOLLAND N.V. 's-Hertogenbosch
CHK. <i>[Signature]</i> DATE 21-11-73	DE. DATE	WIRE-RANGE ⚠	INSUL.-RANGE	
APP. <i>[Signature]</i> DATE 19/11/73	SCALE N.T.S.	SIZE B	NO. C-160631	REV. M
NAME MINIATURE SPLICE				