

### 3408

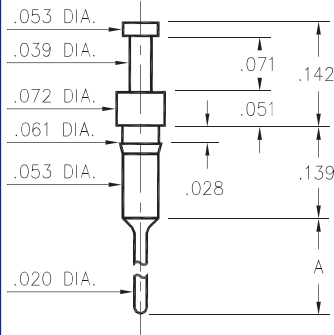

Basic Part Number	Pin Length A
3408-1	.121
3408-2	.181

**3408-X-00-XX-00-00-03-0**  
Press-fit in .057 mounting hole

### 0270/0282

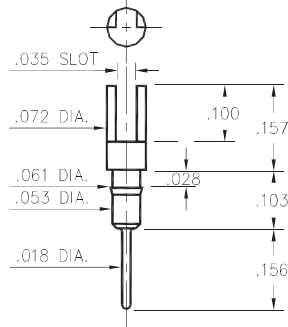

Basic Part Number	Pin Material
0270-0	Ph Br 544 (B2)
0282-0	Brass 360

**02XX-0-01-XX-00-00-03-0**  
Press-fit in .057 mounting hole

### 0700

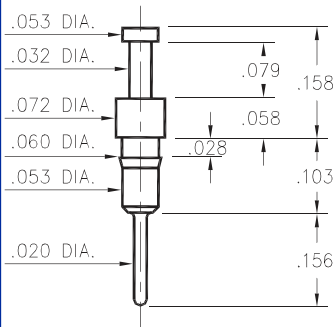

**0700-0-00-XX-00-00-03-0**  
Press-fit in .057 mounting hole

### 8006

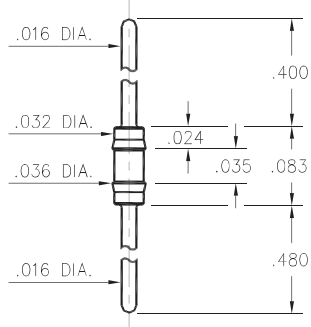

**8006-0-00-XX-00-00-03-0**  
Press-fit in .034 mounting hole

### 0265

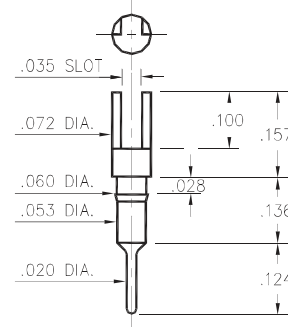

**0265-0-01-XX-00-00-03-0**  
Press-fit in .057 mounting hole

### 0275

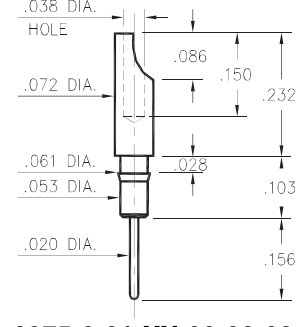

**0275-0-01-XX-00-00-03-0**  
Press-fit in .057 mounting hole  
Pin material is Ph. Br. 544 (B2)  
Accepts wire sizes up to .028" Dia.

### 0272

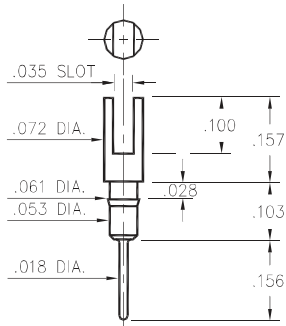

**0272-0-01-XX-00-00-03-0**  
Press-fit in .057 mounting hole

### 8000

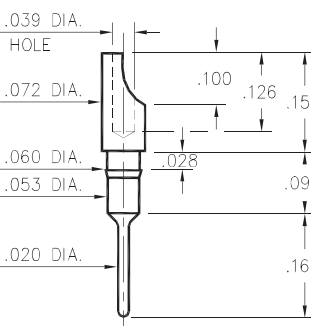

**8000-0-01-XX-00-00-03-0**  
Press-fit in .057 mounting hole  
Accepts wire sizes up to .029" Dia.

### 3603

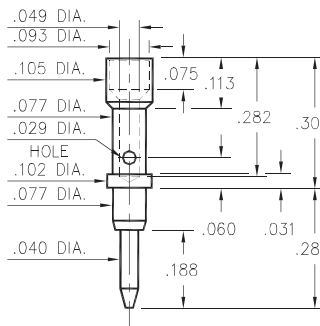

**3603-0-07-XX-00-00-08-0**  
Annealed  
Wire Crimp Termination. Accepts wire sizes 20 AWG Max. / 24 AWG Min.

### 9976

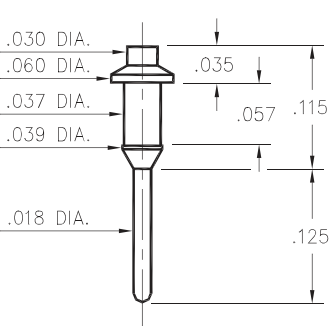

**9976-0-00-XX-00-00-03-0**  
Press-fit in .038 mounting hole

#### SPECIFICATIONS

**PIN MATERIAL:**  
Brass Alloy 360, 1/2 Hard  
(Except where noted)

**DIMENSION IN INCHES**  
**TOLERANCES ON:**  
LENGTHS: ±.005  
DIAMETERS: ±.002  
ANGLES: ± 2°

**ORDER CODE: XXXX - X - 0X - XX - 00 - 00 - XX - 0**

**BASIC PART #**

**SPECIFY PIN FINISH:**

- 01 200µ" TIN/LEAD OVER NICKEL
- ◇ 80 200µ" TIN OVER NICKEL (RoHS)
- ◇ 15 10µ" GOLD OVER NICKEL (RoHS)
- ◇ 21 20µ" GOLD OVER NICKEL (RoHS)
- ◇ 34 50µ" GOLD OVER NICKEL (RoHS)

