

NEW

TB Series Open Core & Coil Industrial Control Transformers

Acme's TB Series Industrial Control Transformers are especially designed to accommodate the momentary current inrush caused when electromagnetic components are energized... without sacrificing secondary voltage stability beyond practical limits.

Acme's TB Series transformers are dry-type, step-down transformers with the secondary control circuit isolated from the primary line circuit to assure maximum safety.

Voltage regulation of Acme's TB Series transformers exceeds standards recommended by the National Electrical Manufacturers Association. Secondary circuit voltage drop between no-load and momentary overload remains exceptionally low. This excellent secondary circuit voltage regulation assures reliable operation of electromagnetic components and may permit the use of a smaller and less expensive industrial control transformer.

FEATURES & BENEFITS

- 600 volt class and below.
- 50–1000 VA, 50/60 Hz.
- 80°C temperature rise, 130°C insulation class.
- Constructed with high quality silicon steel lamination to minimize core losses and increase efficiency.
- Designs incorporate precision split bobbin wound coils for improved regulation.
- Primary fuse blocks and secondary fuse kits available and easily adaptable.
- Series-parallel connecting links save wiring and labor costs.
- Terminal blocks allow full access for ring terminals for easy installation even with solid strand conductors.
- Integrally molded terminal blocks with isolation barriers to prevent arc over.
- Footprint matches TA Series for easy interchangeability.
- Copper windings on all groups.
- Heavy gauge steel mounting plate adapts to various mounting dimensions.
- Voltage regulation exceeds NEMA requirements.
- UL Listed and CSA Certified.
- Meets or exceeds UL, CSA, NEMA, ANSI and OSHA Standards.
- Ten-year limited warranty.

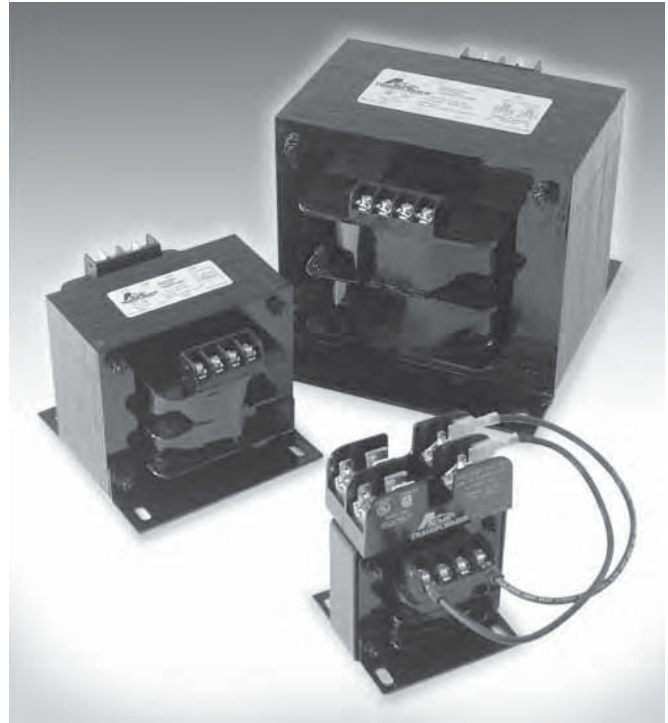

APPLICATIONS

- Motor Starters
- Contactors
- Solenoids
- Timer Circuits
- Relays
- Control Panels
- Robotics

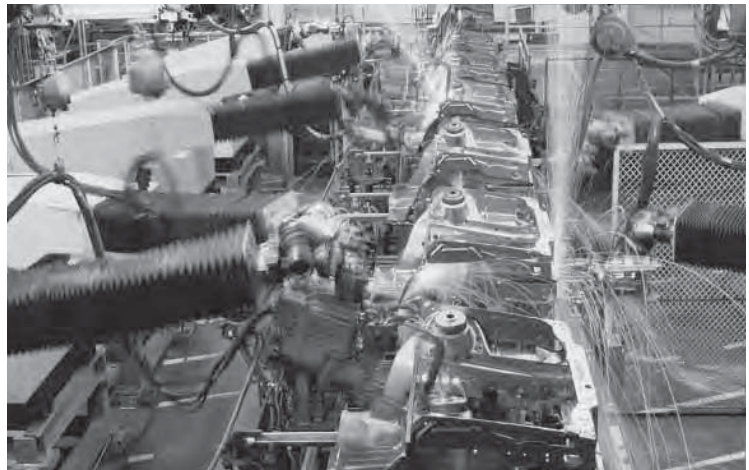

NEW

TB Series Primary Fuse Kits

Type PL112700 Through PL112705:
Using 2 Class CC Dual Element Fuses (not supplied)

- Meets NEC Article 450 and UL-508 requirements.
- For use with class "CC" fuses.
- Eliminates remote mounting of primary overcurrent protection.
- Covered by Acme Electric 10-year limited warranty.

Field installation is fast and easy. Simply loosen the mounting hardware (Fig. 1), slide the bracket over the transformer and re-tighten the mounting hardware. Make the proper connections with the factory furnished jumpers (Fig. 2) and your unit is ready for operation.

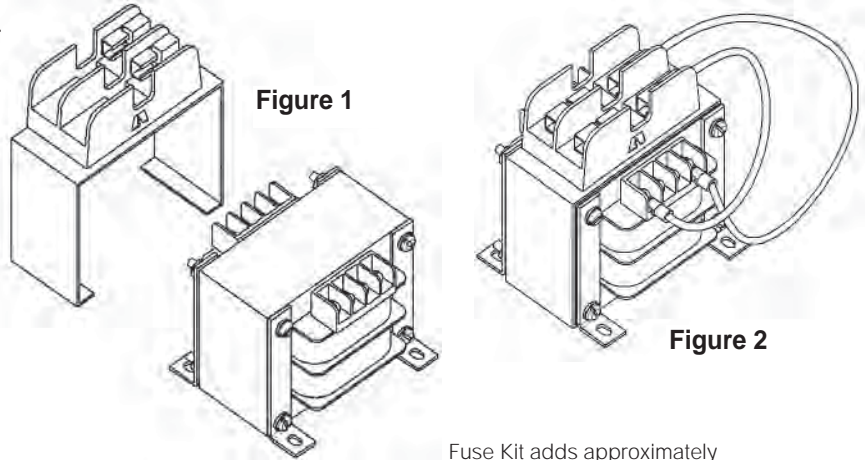

Fuse Kit adds approximately 1.75" to height of unit.

Primary Fuse Sizing Chart^①

VA	120 V	208 V	230 V	240 V	277 V	380 V	416 V	440 V	460 V	480 V	550 V	600 V
50	1.2	0.6	0.6	0.6	0.6	0.3	0.3	0.3	0.3	0.3	0.3	0.3
75	1.9	1.0	1.0	1.0	0.8	0.6	0.6	0.6	0.5	0.5	0.4	0.4
100	2.5	1.5	1.3	1.3	1.0	0.8	0.8	0.6	0.6	0.6	0.6	0.5
150	3.8	2.0	2.0	1.9	1.5	1.2	1.2	1.0	1.0	1.0	0.8	0.8
250	3.5	3.5	3.5	3.0	3.0	2.0	1.8	1.8	1.5	1.5	1.4	1.2
300	4.0	4.0	4.0	3.5	3.0	2.5	2.5	2.0	2.0	1.9	1.5	1.5
350	5.0	5.0	4.5	4.0	4.0	2.5	2.5	2.5	2.0	2.0	1.9	1.8
500	7.0	4.0	3.5	3.5	5.5	4.0	3.5	3.5	3.5	3.0	3.0	2.5
750	10.0	6.0	5.5	5.0	4.5	6.0	5.5	5.0	5.0	5.0	4.0	4.0
1000	15.0	8.0	7.0	7.0	6.0	4.5	4.0	3.5	3.5	3.5	5.5	5.0
1500	20.0	12.0	12.0	12.0	10.0	7.0	6.0	6.0	5.5	5.5	5.0	4.5
2000	25.0	12.0	15.0	15.0	12.0	9.0	8.0	8.0	7.5	7.0	6.0	6.0
3000	30.0	20.0	20.0	20.0	15.0	15.0	12.0	12.0	12.0	12.0	10.0	9.0
5000	—	30.0	30.0	30.0	25.0	20.0	15.0	15.0	15.0	15.0	12.0	15.0

Secondary Fuse Sizing Chart

VA	24 V	85 V	91 V	99 V	100 V	110 V	115 V	120 V	125 V	130 V
50 VA	3.2	0.9	0.9	0.8	0.8	0.7	0.7	0.6	0.6	0.6
75 VA	5.0	1.4	1.2	1.2	1.2	1.0	1.0	1.0	1.0	0.8
100 VA	6.0	1.5	1.5	1.5	1.5	1.5	1.5	1.2	1.2	1.2
150 VA	10.0	2.5	2.5	2.5	2.5	2.0	2.0	2.0	2.0	1.5
250 VA	12.0	4.5	4.5	4.0	4.0	3.5	3.5	3.0	3.0	3.0
300 VA	15.0	5.5	5.5	5.0	5.0	4.5	4.5	4.0	4.0	3.5
350 VA	20.0	6.5	6.0	5.5	5.5	5.0	5.0	4.5	4.5	4.5
500 VA	25.0	9.0	9.0	8.0	8.0	7.0	7.0	6.0	6.0	6.0
750 VA	40.0	12.0	12.0	12.0	12.0	10.0	10.0	10.0	10.0	9.0
1000 VA	50.0	15.0	15.0	12.0	12.0	12.0	12.0	12.0	12.0	12.0
1500 VA	—	25.0	20.0	20.0	20.0	20.0	20.0	15.0	15.0	15.0
2000 VA	—	30.0	30.0	25.0	25.0	25.0	25.0	20.0	20.0	20.0
3000 VA	—	40.0	40.0	40.0	40.0	35.0	35.0	30.0	30.0	30.0
5000 VA	—	70.0	70.0	60.0	60.0	60.0	60.0	50.0	50.0	50.0

^① Fuse size based on time delay class CC fuses.

NOTE: Bold lines indicate changes in the percent of rated current used to calculate fuse sizes in accordance with article 450 of the NEC.

NEW

TB Series Secondary Fuse Kits

Type PL79924, PL79930, & PL79931: Use Dual Element Slow-Blow Fuse

Catalog Number	VA	Type
PL79924*	50-1000	1/4" x 1-1/4"
PL79930	50-350	13/32" x 1-1/2"
PL79931	500-1000	13/32" x 1-1/2"

- Mount secondary fuse clips on terminals X1 and F or F1 using the screws supplied with the transformer.
- Connect secondary load lines to terminals X2 and F or F2. Use Jumper Link to connect F1 and F2.
- Use dual-element slow-blowing fuses such as Bussmann MFG., Fusetron Type FNM, Littelfuse or Ferraz Shawmut (not supplied with fuse kits).

* PL79924: Use fuse kit on all transformers except 750 & 1000 VA with 24 volt secondary.

Secondary Fuse Kit

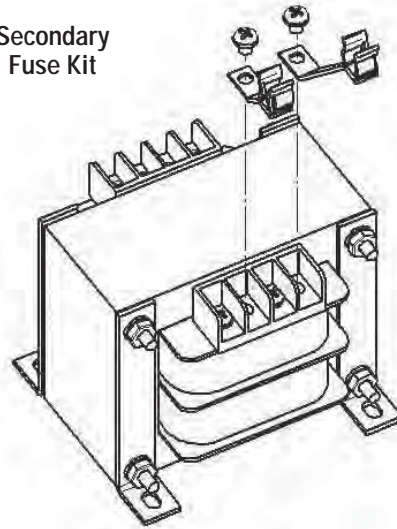

Instructions for TB Series Secondary Fuse Kit

Type PL112603: use dual element slow-blow fuse 13/32" x 1-1/2" (1.0 x 3.8 cm)

1. To attach secondary fuse kit PL 112603 to primary fuse kits PL112700 thru PL112705 snap the secondary single pole fuse block onto the unlabeled side of the primary double pole fuse block. (See Figure 1)
2. Install the fuse kits as instructed under the primary fuse kit instructions on page 70.
3. Select the appropriate pair of jumpers for making the connections between the secondary fuse block and the secondary (X-side) of the transformer.
4. Connect the female quick-connect of the jumpers supplied to one of the male quick-connects of the secondary fuse block—one jumper to each end of the fuse block. (See Figure 2)
5. Connect the ring terminal of the jumpers supplied to screw terminals X1 and F or F1 on the secondary (X-side) of the transformer.
6. Connect secondary load lines to terminals X2 and F or F2.

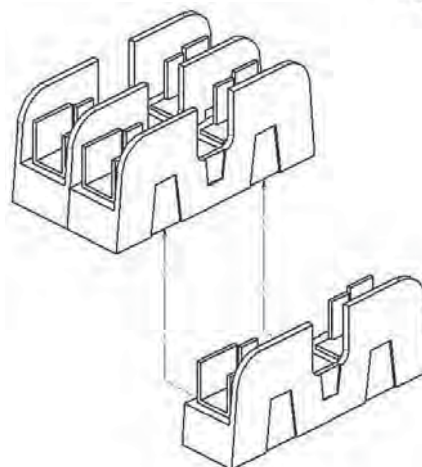

Figure 1

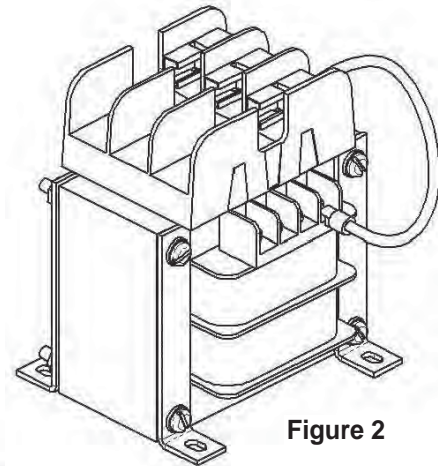

Figure 2

SELECTION CHARTS

NEW

GROUP A



120 X 240 PRIMARY VOLTS—12/24 SECONDARY VOLTS—1Ø, 50/60 Hz

CATALOG NO. ②	VA RATING	OUTPUT AMPS	APPROX. DIMENSIONS Inches (Cm.)						APPROX. SHIP WEIGHT Lbs. (Kg.)	PRIMARY FUSE BLOCK PART NO.	SECONDARY FUSE SIZE 24 VOLTS
			A	B	C	D	E	F			
TB181141 ②	50	2.08	4.23 (10.7)	3.00 (7.6)	2.70 (6.8)	2.50 (6.4)	2.13 (5.4)	.22 x .50 (0.6 x 1.3)	4 (1.8)	PL112700	3 ² / ₁₀ amps
TB181142 ②	75	3.13	4.74 (12.0)	3.00 (7.6)	2.70 (6.8)	2.50 (6.4)	2.61 (6.6)	.22 x .50 (0.6 x 1.3)	4 (1.8)	PL112700	5 amps
TB181143 ②	100	4.17	4.90 (12.4)	3.00 (7.6)	2.70 (6.8)	2.50 (6.4)	2.81 (7.1)	.22 x .50 (0.6 x 1.3)	4 (1.8)	PL112700	6 ¹ / ₄ amps
TB181144 ②	150	6.25	4.78 (12.1)	3.75 (9.5)	3.40 (8.6)	3.13 (8.0)	2.63 (6.7)	.22 x .50 (0.6 x 1.3)	6 (2.7)	PL112701	10 amps
TB181146 ②	250	10.42	5.08 (12.9)	4.50 (11.4)	3.84 (9.8)	3.75 (9.5)	3.05 (7.7)	.22 x .50 (0.6 x 1.3)	9 (4.1)	PL112702	15 amps
TB181148 ②	350	14.58	6.12 (15.5)	4.50 (11.4)	3.84 (9.8)	3.75 (9.5)	4.06 (10.3)	.22 x .50 (0.6 x 1.3)	13 (5.9)	PL112702	20 amps
TB181149 ②	500	20.83	5.90 (15.0)	5.25 (13.3)	4.47 (11.4)	4.38 (11.1)	4.19 (10.6)	.31 x .50 (0.8 x 1.3)	16 (7.3)	PL112704	30 amps
TB181150	750	31.25	7.53 (19.1)	5.25 (13.3)	4.47 (11.4)	4.38 (11.1)	5.25 (13.3)	.31 x .50 (0.8 x 1.3)	24 (10.9)	PL112704	—
TB181151	1000	41.67	7.43 (18.9)	6.75 (17.1)	5.72 (14.5)	5.75 (14.6)	3.81 (9.7)	.31 x .50 (0.8 x 1.3)	26 (11.8)	PL112705	—

GROUP B

240 X 480, 230 X 460, 220 X 440 PRIMARY VOLTS—120/115/110 SECONDARY VOLTS—1Ø, 50/60 Hz

CATALOG NO. ②	VA RATING	OUTPUT AMPS @ 120V	APPROX. DIMENSIONS INCHES (CM.)						APPROX. SHIP WEIGHT LBS. (KG.)	PRIMARY FUSE BLOCK PART NO.	SECONDARY FUSE KIT ① PART NO.	SECONDARY FUSE SIZE 120 VOLTS
			A	B	C	D	E	F				
TB81210 ②	50	0.42	4.23 (10.7)	3.00 (7.6)	2.70 (6.8)	2.50 (6.4)	2.13 (5.4)	.22 x .50 (0.6 x 1.3)	4 (1.8)	PL112700	*	6 ¹ / ₁₀ amp
TB81201 ②	75	0.63	4.74 (12.0)	3.00 (7.6)	2.70 (6.8)	2.50 (6.4)	2.61 (6.6)	.22 x .50 (0.6 x 1.3)	4 (1.8)	PL112700	*	1 amp
TB81211 ②	100	0.83	4.90 (12.4)	3.00 (7.6)	2.70 (6.8)	2.50 (6.4)	2.81 (7.1)	.22 x .50 (0.6 x 1.3)	4 (1.8)	PL112700	*	1 ¹ / ₄ amps
TB81212 ②	150	1.25	5.00 (12.7)	3.75 (9.5)	3.40 (8.6)	3.13 (8.0)	2.81 (7.1)	.22 x .50 (0.6 x 1.3)	6 (2.7)	PL112701	*	2 amps
TB81213 ②	250	2.08	5.57 (14.1)	4.50 (11.4)	3.84 (9.8)	3.75 (9.5)	3.13 (8.0)	.22 x .50 (0.6 x 1.3)	9 (4.1)	PL112702	*	3 ² / ₁₀ amps
TB81200 ②	300	2.50	5.57 (14.1)	4.50 (11.4)	3.84 (9.8)	3.75 (9.5)	3.13 (8.0)	.22 x .50 (0.6 x 1.3)	10 (4.5)	PL112702	*	4 amps
TB81214 ②	350	2.92	6.32 (16.1)	4.50 (11.4)	3.84 (9.8)	3.75 (9.5)	3.83 (9.7)	.22 x .50 (0.6 x 1.3)	12 (5.4)	PL112702	*	4 ¹ / ₂ amps
TB81215 ②	500	4.17	6.30 (16.0)	5.25 (13.3)	4.47 (11.4)	4.06 (10.3)	3.81 (9.7)	.22 x .50 (0.6 x 1.3)	15 (6.8)	PL112704	*	6 ¹ / ₄ amps
TB81216 ②	750	6.25	6.65 (16.9)	5.25 (13.3)	4.47 (11.4)	4.38 (11.1)	5.13 (13.0)	.31 x .50 (0.8 x 1.3)	23 (10.4)	PL112704	*	10 amps
TB81217 ②	1000	8.33	7.58 (19.3)	6.75 (17.1)	5.78 (14.7)	5.75 (14.6)	3.69 (9.4)	.31 x .50 (0.8 x 1.3)	25 (11.3)	PL112705	*	12 amps

① Secondary Fuse Kit PL112603 may be substituted for PL112600 thru PL112602 when Primary Fuse Kit is used. See page 62.

② See chart for integrally mounted fuse block catalog number suffix.

GROUP B

(CONTINUED)



240 X 480, 230 X 460, 220 X 440 PRIMARY VOLTS—120/115/110 SECONDARY VOLTS—1Ø, 50/60 Hz

CATALOG NO. ②	VA RATING	OUTPUT AMPS @ 120V	APPROX. DIMENSIONS INCHES (CM.)						APPROX. SHIP WEIGHT LBS. (KG.)	PRIMARY FUSE BLOCK PART NO.	SECONDARY FUSE KIT ① PART NO.	SECONDARY FUSE SIZE 120 VOLTS
			A	B	C	D	E	F				
TA2-81218	1500	12.50	8.80 (22.4)	6.75 (17.1)	5.72 (14.5)	5.75 (14.6)	5.75 (14.6)	.31 x .50 (0.8 x 1.3)	43 (19.5)	PL112705	PL112601	15 amps
TA2-81219	2000	16.67	9.25 (23.5)	6.75 (17.1)	5.72 (14.5)	5.75 (14.6)	6.38 (16.2)	.31 x .50 (0.8 x 1.3)	49 (22.2)	PL112705	PL112601	20 amps
TA2-81220	3000	25.00	8.81 (22.4)	7.50 (19.1)	8.34 (21.2)	6.50 (16.5)	7.52 (19.1)	.41 x .81 (1.0 x 2.1)	70 (31.8)	PL112706	—	—
TA281221	5000	41.67	7.52 (19.1)	11.92 (30.3)	9.49 (24.1)	6.75 (17.1)	6.25 (15.9)	.41 x .81 (1.0 x 2.1)	125 (56.7)	PL112707	—	—

* See fusing chart for secondary fuse kits.

Integrally Mounted Fuse Blocks Available:
(See Chart)

GROUP 'A' THROUGH 500 VA

GROUP 'B' THROUGH 1000 VA

ADD SUFFIX TO CATALOG NO.	CONFIGURATION
F2	Factory installed integrally mounted 2-pole primary block
F3	Factory installed integrally mounted 3-pole primary and secondary block (100 VA & larger)
F4	Factory installed 2-pole primary block and secondary fuse clips (50 & 75 VA)

Consult factory for other sizes available.

GROUP C

240/480/600, 230/460/575, 220/440/550 PRIMARY VOLTS—120/100, 115/95, 110/90 SECONDARY VOLTS—1Ø, 50/60 Hz

CATALOG NO.	VA RATING	OUTPUT AMPS @ 120V	APPROX. DIMENSIONS INCHES (CM.)						APPROX. SHIP WEIGHT LBS. (KG.)	PRIMARY FUSE BLOCK PART NO.	SECONDARY FUSE KIT ① PART NO.	SECONDARY FUSE SIZE 120 VOLTS
			A	B	C	D	E	F				
TB81000	50	0.42	4.56 (11.6)	3.00 (7.6)	2.70 (6.8)	2.50 (6.4)	2.61 (6.6)	.22 x .50 (0.6 x 1.3)	4 (1.8)	PL112700	✱	⁶ / ₁₀ amp
TB81009	75	0.63	4.90 (12.4)	3.00 (7.6)	2.70 (6.8)	2.50 (6.4)	2.81 (7.1)	.22 x .50 (0.6 x 1.3)	4 (1.8)	PL112700	✱	1 amp
TB81001	100	0.83	5.36 (13.6)	3.00 (7.6)	2.70 (6.8)	2.50 (6.4)	3.26 (8.3)	.22 x .50 (0.6 x 1.3)	5 (2.3)	PL112700	✱	1 ¹ / ₄ amps
TB81002	150	1.25	5.00 (12.7)	3.75 (9.5)	3.40 (8.6)	3.13 (8.0)	3.06 (7.8)	.22 x .50 (0.6 x 1.3)	7 (3.2)	PL112701	✱	2 amps
TB81003	250	2.08	5.57 (14.1)	4.50 (11.4)	3.84 (9.8)	3.75 (9.5)	3.50 (8.9)	.22 x .50 (0.6 x 1.3)	11 (5.0)	PL112702	✱	3 ² / ₁₀ amps
TB81020	300	2.50	6.48 (16.5)	4.65 (11.8)	4.15 (10.5)	4.06 (10.3)	4.06 (10.3)	.22 x .50 (0.6 x 1.3)	15 (6.8)	PL112702	✱	4 amps
TB81004	350	2.92	6.48 (16.5)	4.65 (11.8)	4.15 (10.5)	4.06 (10.3)	4.06 (10.3)	.22 x .50 (0.6 x 1.3)	15 (6.8)	PL112702	✱	4 ¹ / ₂ amps
TB81005	500	4.17	6.43 (16.3)	5.25 (13.3)	4.47 (11.4)	4.38 (11.1)	4.56 (11.6)	.31 x .50 (0.8 x 1.3)	21 (9.5)	PL112704	✱	6 ¹ / ₄ amps
TB81006	750	6.25	7.19 (18.3)	6.75 (17.1)	5.78 (14.7)	5.75 (14.6)	3.81 (9.7)	.31 x .50 (0.8 x 1.3)	25 (11.3)	PL112705	✱	10 amps
TB81007	1000	8.33	7.96 (20.2)	6.75 (17.1)	5.78 (14.7)	5.75 (14.6)	4.63 (11.8)	.31 x .50 (0.8 x 1.3)	32 (14.5)	PL112705	✱	12 amps
TA281008	1500	12.50	9.46 (24.0)	6.75 (17.1)	5.72 (14.5)	5.75 (14.6)	6.38 (16.2)	.31 x .50 (0.8 x 1.3)	47 (21.3)	PL112705	PL112601	15 amps
TA253929	2000	16.67	7.90 (20.1)	7.50 (19.1)	7.66 (19.5)	6.50 (16.5)	6.57 (16.7)	.41 x .81 (1.0 x 2.1)	55 (24.9)	PL112706	PL112601	20 amps
TA253930	3000	25.00	7.02 (17.8)	11.92 (30.3)	8.83 (22.4)	6.75 (17.1)	5.75 (14.6)	.41 x .81 (1.0 x 2.1)	75 (34.0)	PL112707	—	—
TA253931	5000	41.67	7.52 (19.1)	11.92 (30.3)	9.49 (24.1)	6.75 (17.1)	6.25 (15.9)	.41 x .81 (1.0 x 2.1)	110 (49.9)	PL112707	—	—

* See fusing chart for secondary fuse kits.

① Secondary Fuse Kit PL-112603 may be substituted for PL112600 thru PL112602 when Primary Fuse Kit is used. See page 62.

② See chart for integrally mounted fuse block catalog number suffix.

GROUP D



208/240/277/380/480 PRIMARY VOLTS—24 SECONDARY VOLTS—1Ø, 50/60 Hz

CATALOG NO.	VA RATING	OUTPUT AMPS	APPROX. DIMENSIONS INCHES (CM.)						APPROX. SHIP WEIGHT LBS. (KG.)	PRIMARY FUSE BLOCK PART NO.	SECONDARY FUSE KIT ① PART NO.	SECONDARY FUSE SIZE 24 VOLTS
			A	B	C	D	E	F				
TB81321	50	2.08	4.08 (10.4)	3.75 (9.5)	3.40 (8.6)	3.13 (8.0)	2.19 (5.6)	.22 x .50 (0.6 x 1.3)	4 (1.8)	PL112701	*	3 ² / ₁₀ amp
TB81322	75	3.13	4.31 (10.9)	3.75 (9.5)	3.40 (8.6)	3.13 (8.0)	2.31 (5.9)	.22 x .50 (0.6 x 1.3)	5 (2.3)	PL112701	*	5 amps
TB81323	100	4.17	4.52 (11.5)	3.75 (9.5)	3.40 (8.6)	3.13 (8.0)	2.63 (6.7)	.22 x .50 (0.6 x 1.3)	5 (2.3)	PL112701	*	6 ¹ / ₄ amps
TB81324	150	6.25	4.75 (12.1)	4.50 (11.4)	3.84 (9.8)	3.75 (9.5)	3.05 (7.7)	.22 x .50 (0.6 x 1.3)	9 (4.1)	PL112702	*	10 amps
TB81325	250	10.42	5.24 (13.3)	4.65 (11.8)	4.15 (10.5)	4.06 (10.3)	3.25 (8.3)	.22 x .50 (0.6 x 1.3)	11 (5.0)	PL112702	*	15 amps
TB81326	350	14.58	6.02 (15.3)	5.25 (13.3)	4.47 (11.4)	4.38 (11.1)	4.00 (10.2)	.31 x .50 (0.8 x 1.3)	18 (8.2)	PL112704	*	20 amps
TB81327	500	20.83	6.51 (16.5)	5.25 (13.3)	4.47 (11.4)	4.38 (11.1)	4.19 (10.6)	.31 x .50 (0.8 x 1.3)	19 (8.6)	PL112704	*	30 amps
TB81328	750	31.25	7.08 (18.0)	6.75 (17.1)	5.78 (14.7)	5.75 (14.6)	3.81 (9.7)	.31 x .50 (0.8 x 1.3)	26 (11.8)	PL112705	*	— 33 amps
TB81329	1000	41.67	8.10 (20.6)	6.75 (17.1)	5.72 (14.5)	5.75 (14.6)	4.63 (11.8)	.31 x .50 (0.8 x 1.3)	33 (15.0)	PL112705	*	—

* See fusing chart for secondary fuse kits.

GROUP E

208/277/380 PRIMARY VOLTS—115/95 SECONDARY VOLTS—1Ø, 50/60 Hz

CATALOG NO.	VA RATING	OUTPUT AMPS @ 115V	APPROX. DIMENSIONS INCHES (CM.)						APPROX. SHIP WEIGHT LBS. (KG.)	PRIMARY FUSE BLOCK PART NO.	SECONDARY FUSE KIT ① PART NO.	SECONDARY FUSE SIZE 115 VOLTS
			A	B	C	D	E	F				
TB81301	50	0.43	4.35 (11.0)	3.00 (7.6)	2.70 (6.8)	2.50 (6.4)	2.61 (6.6)	.22 x .50 (0.6 x 1.3)	4 (1.8)	PL112700	*	6 ¹ / ₁₀ amp
TB81302	75	0.65	4.74 (12.0)	3.00 (7.6)	2.70 (6.8)	2.50 (6.4)	2.81 (7.1)	.22 x .50 (0.6 x 1.3)	4 (1.8)	PL112700	*	1 amp
TB81303	100	0.87	4.45 (11.3)	3.75 (9.5)	3.40 (8.6)	3.13 (8.0)	2.44 (6.2)	.22 x .50 (0.6 x 1.3)	5 (2.3)	PL112701	*	1 ¹ / ₄ amps
TB81304	150	1.30	5.00 (12.7)	3.75 (9.5)	3.84 (9.8)	3.13 (8.0)	3.06 (7.8)	.22 x .50 (0.6 x 1.3)	5 (2.3)	PL112701	*	2 amps
TB81305	250	2.17	5.68 (14.4)	4.50 (11.4)	3.84 (9.8)	3.75 (9.5)	4.06 (10.3)	.22 x .50 (0.6 x 1.3)	13 (5.9)	PL112702	*	3 ¹ / ₂ amps
TB81306	350	3.04	6.30 (16.0)	4.65 (11.8)	4.15 (10.5)	4.06 (10.3)	4.75 (12.1)	.22 x .50 (0.6 x 1.3)	18 (8.2)	PL112702	*	5 amps
TB81307	500	4.35	6.22 (15.8)	5.25 (13.3)	4.47 (11.4)	4.38 (11.1)	4.56 (11.6)	.22 x .50 (0.6 x 1.3)	20 (9.1)	PL112704	*	7 amps
TB81308	750	6.52	6.82 (17.3)	6.75 (17.1)	5.78 (14.7)	5.75 (14.6)	3.69 (9.4)	.31 x .50 (0.8 x 1.3)	24 (10.9)	PL112705	*	10 amps
TB81309	1000	8.70	7.96 (20.2)	6.75 (17.1)	5.72 (14.5)	5.75 (14.6)	4.44 (11.3)	.31 x .50 (0.8 x 1.3)	31 (14.1)	PL112705	*	12 amps

* See fusing chart for secondary fuse kits.

① Secondary Fuse Kit PL112603 may be substituted for PL112600 thru PL112602 when Primary Fuse Kit is used. See page 62.

② See chart for integrally mounted fuse block catalog number suffix.

GROUP F



380/440/550/600 PRIMARY VOLTS—115/230 SECONDARY VOLTS—1Ø, 50/60 Hz

CATALOG NO.	VA RATING	OUTPUT AMPS @ 115V	APPROX. DIMENSIONS INCHES (CM.)						APPROX. SHIP WEIGHT LBS. (KG.)	PRIMARY FUSE BLOCK PART NO.	SECONDARY FUSE SIZE ② 115 VOLTS
			A	B	C	D	E	F			
TA254535	50	0.43	4.12 (10.5)	3.75 (9.5)	3.21 (8.2)	3.13 (8.0)	2.19 (5.6)	.22 x .50 (0.6 x 1.3)	4 (1.8)	PL112701	6/10 amp
TA254536	100	0.87	4.56 (11.6)	3.75 (9.5)	3.21 (8.2)	3.13 (8.0)	2.31 (5.9)	.22 x .50 (0.6 x 1.3)	5 (2.3)	PL112701	1 1/4 amps
TA254537	150	1.30	5.00 (12.7)	3.75 (9.5)	3.21 (8.2)	3.13 (8.0)	3.06 (7.8)	.22 x .50 (0.6 x 1.3)	10 (4.5)	PL112701	2 amps
TA254538	250	2.17	5.49 (13.9)	4.50 (11.4)	3.84 (9.8)	3.75 (9.5)	3.50 (8.9)	.22 x .50 (0.6 x 1.3)	11 (5.0)	PL112702	3 1/2 amps
TA281197	350	3.04	6.03 (15.3)	4.88 (12.4)	4.15 (10.5)	4.06 (10.3)	4.38 (11.1)	.22 x .50 (0.6 x 1.3)	17 (7.7)	PL112703	5 amps
TA254539	500	4.35	6.76 (17.1)	4.88 (12.4)	4.15 (10.5)	4.06 (10.3)	5.75 (14.6)	.22 x .50 (0.6 x 1.3)	23 (10.4)	PL112703	7 amps
TA281240	750	6.52	7.19 (18.3)	6.75 (17.1)	5.72 (14.5)	5.75 (14.6)	3.69 (9.4)	.31 x .50 (0.8 x 1.3)	25 (11.3)	PL112705	10 amps
TA281241	1000	8.70	7.77 (19.7)	6.75 (17.1)	5.72 (14.5)	5.75 (14.6)	4.44 (11.3)	.31 x .50 (0.8 x 1.3)	30 (13.6)	PL112705	12 amps

GROUP G

240/416/480/600; 230/400/460/575; 220/380/440/550; 208/500 PRIMARY VOLTS

99/120/130; 95/115/125; 91/110/120; 85/100/110 SECONDARY VOLTS —1Ø, 50/60 Hz

CATALOG NO.	VA RATING @ 130V	OUTPUT AMPS	APPROX. DIMENSIONS INCHES (CM.)						APPROX. SHIP WEIGHT LBS. (KG.)	PRIMARY FUSE BLOCK PART NO.	SECONDARY FUSE KIT PART NO.	SECONDARY FUSE SIZE 130 VOLTS
			A	B	C	D	E	F				
TB32403	50	0.38	4.08 (10.4)	3.75 (9.5)	3.40 (8.6)	3.13 (8.0)	2.31 (5.9)	.22 x .50 (0.6 x 1.3)	5 (2.3)	PL112701	NA	6/10 amp
TB32404	150	1.15	4.75 (12.1)	4.50 (11.4)	3.84 (9.8)	3.75 (9.5)	3.05 (7.7)	.22 x .50 (0.6 x 1.3)	10 (4.5)	PL112702	NA	1 6/10 amps
TB32405	250	1.92	5.58 (14.2)	4.65 (11.8)	4.15 (10.5)	4.06 (10.3)	4.06 (10.3)	.22 x .50 (0.6 x 1.3)	16 (7.3)	PL112702	NA	3 2/10 amps
TB32669	350	2.69	6.23 (15.8)	4.65 (11.8)	4.15 (10.5)	4.06 (10.3)	5.50 (14.0)	.22 x .50 (0.6 x 1.3)	22 (10.0)	PL112702	NA	4 amps
TB32406	500	3.85	6.40 (16.3)	6.75 (17.1)	5.78 (14.7)	5.75 (14.6)	3.69 (9.4)	.22 x .50 (0.6 x 1.3)	23 (10.4)	PL112705	NA	6 1/4 amps
TB54523	750	5.77	7.08 (18.0)	6.75 (17.1)	5.78 (14.7)	5.75 (14.6)	4.13 (10.5)	.31 x .50 (0.8 x 1.3)	29 (13.2)	PL112705	NA	9 amps
TB54524	1000	7.69	8.56 (21.7)	6.75 (17.1)	5.78 (14.7)	5.75 (14.6)	4.88 (12.4)	.31 x .50 (0.8 x 1.3)	35 (15.9)	PL112705	NA	12 amps
TA254525	1500	11.54	6.75 (17.1)	7.50 (19.1)	7.66 (19.5)	6.50 (16.5)	5.42 (13.8)	.41 x .81 (1.0 x 2.1)	55 (24.9)	PL112706	PL-112601	20 amps
TA281202	2000	15.39	7.45 (18.9)	7.50 (19.1)	7.66 (19.5)	6.50 (16.5)	6.12 (15.5)	.41 x .81 (1.0 x 2.1)	55 (24.9)	PL112706	PL-112601	25 amps
TA281203	3000	23.08	7.02 (17.8)	11.92 (30.3)	8.83 (22.4)	6.75 (17.1)	5.75 (14.6)	.41 x .81 (1.0 x 2.1)	70 (31.8)	PL112707	—	—
TA281205	5000	38.46	7.52 (19.1)	11.92 (30.3)	9.49 (24.1)	6.75 (17.1)	6.25 (15.9)	.41 x .81 (1.0 x 2.1)	110 (49.9)	PL112707	—	—

① Secondary Fuse Kit PL112603 may be substituted for PL112600 thru PL112602 when Primary Fuse Kit is used. See page 62.

② Secondary fuse kit application for 115V only.



CONNECTION DETAILS FOR GROUP G

CONNECT TO LINE FOR RESPECTIVE VOLTAGE				OUTPUT VOLTS		
H1-H2	H1-H3	H1-H4	H1-H5	X1-X2	X1-X3	X1-X4
208	--	--	500	85	100	110
220	380	440	550	91	110	120
230	400	460	575	95	115	125
240	416	480	600	99	120	130

GROUP H

208/230/460 PRIMARY VOLTS—115 SECONDARY VOLTS—1Ø, 50/60 Hz

CATALOG NO.	VA RATING	OUTPUT AMPS	APPROX. DIMENSIONS INCHES (CM.)						APPROX. SHIP WEIGHT LBS. (KG.)	PRIMARY FUSE BLOCK PART NO.	SECONDARY FUSE KIT ① PART NO.	SECONDARY FUSE SIZE 115 VOLTS
			A	B	C	D	E	F				
TB69300	50	0.43	4.44 (11.3)	3.00 (7.6)	2.70 (6.8)	2.50 (6.4)	2.61 (6.6)	.22 x .50 (0.6 x 1.3)	4 (1.8)	PL112700	*	6/10 amp
TB69301	100	0.87	5.21 (13.2)	3.00 (7.6)	2.70 (6.8)	2.50 (6.4)	3.26 (8.3)	.22 x .50 (0.6 x 1.3)	4 (1.8)	PL112700	*	1 ⁴ / ₁₀ amps
TB69302	150	1.30	5.10 (13.0)	3.75 (9.5)	3.40 (8.6)	3.13 (8.0)	3.06 (7.8)	.22 x .50 (0.6 x 1.3)	7 (3.2)	PL112701	*	2 amps
TB69303	250	2.17	5.38 (13.7)	4.50 (11.4)	3.84 (9.8)	3.75 (9.5)	3.50 (8.9)	.22 x .50 (0.6 x 1.3)	11 (5.0)	PL112702	*	3 ¹ / ₂ amps
TB69304	350	3.04	5.90 (15.0)	4.65 (11.8)	4.15 (10.5)	4.06 (10.3)	3.81 (9.7)	.22 x .50 (0.6 x 1.3)	15 (6.8)	PL112702	*	5 amps
TB69305	500	4.35	6.22 (15.8)	5.25 (13.3)	4.47 (11.4)	4.38 (11.1)	4.56 (11.6)	.31 x .50 (0.8 x 1.3)	20 (9.1)	PL112704	*	7 amps
TB69306	750	6.52	6.82 (17.3)	6.75 (17.1)	5.78 (14.7)	5.75 (14.6)	3.81 (9.7)	.31 x .50 (0.8 x 1.3)	26 (11.8)	PL112705	*	10 amps
TB69307	1000	8.70	7.96 (20.2)	6.75 (17.1)	5.78 (14.7)	5.75 (14.6)	4.63 (11.8)	.31 x .50 (0.8 x 1.3)	33 (15.0)	PL112705	*	12 amps

* See fusing chart for secondary fuse kits.

GROUP I

600 PRIMARY VOLTS—12/24 SECONDARY VOLTS—1Ø, 60 Hz

CATALOG NO.	VA RATING	OUTPUT AMPS @ 12V	APPROX. DIMENSIONS INCHES (CM.)						APPROX. SHIP WEIGHT LBS. (KG.)	PRIMARY FUSE BLOCK PART NO.
			A	B	C	D	E	F		
TA83300	50	4.17	4.13 (10.5)	3.00 (7.6)	2.59 (6.6)	2.50 (6.4)	2.30 (5.8)	.22 x .50 (0.6 x 1.3)	4 (1.8)	PL112700
TA83301	100	8.33	4.90 (12.4)	3.00 (7.6)	2.59 (6.6)	2.50 (6.4)	3.35 (8.5)	.22 x .50 (0.6 x 1.3)	4 (1.8)	PL112700
TA83302	150	12.50	4.92 (12.5)	3.75 (9.5)	3.21 (8.2)	3.13 (8.0)	2.81 (7.1)	.22 x .50 (0.6 x 1.3)	6 (2.7)	PL112701
TA83303	250	20.83	5.38 (13.7)	4.50 (11.4)	3.84 (9.8)	3.75 (9.5)	3.05 (7.7)	.22 x .50 (0.6 x 1.3)	9 (4.1)	PL112702
TA83304	500	41.67	6.06 (15.4)	4.88 (12.4)	4.15 (10.5)	4.06 (10.3)	4.06 (10.3)	.22 x .50 (0.6 x 1.3)	13 (5.9)	PL112703
TA83305	750	62.50	6.43 (16.3)	5.25 (13.3)	4.47 (11.4)	4.38 (11.1)	4.00 (10.2)	.31 x .50 (0.8 x 1.3)	21 (9.5)	PL112704
TA83306	1000	83.33	7.30 (18.5)	6.75 (17.1)	5.72 (14.5)	5.75 (14.6)	3.69 (9.4)	.31 x .50 (0.8 x 1.3)	24 (10.9)	PL112705

① Secondary Fuse Kit PL112603 may be substituted for PL112600 thru PL112602 when Primary Fuse Kit is used. See page 62.

GROUP J

240 X 480 PRIMARY VOLTS—120/240 SECONDARY VOLTS—1Ø, 60 Hz

CATALOG NO.	VA RATING	OUTPUT AMPS @ 120V	APPROX. DIMENSIONS INCHES (CM.)						APPROX. SHIP WEIGHT LBS. (KG.)	PRIMARY FUSE BLOCK PART NO.
			A	B	C	D	E	F		
TB83210	50	0.42	4.13 (10.5)	3.00 (7.6)	2.70 (6.8)	2.50 (6.4)	2.30 (5.8)	.22 x .50 (0.6 x 1.3)	4 (1.8)	PL112700
TB83212	100	0.83	4.90 (12.4)	3.00 (7.6)	2.70 (6.8)	2.50 (6.4)	3.35 (8.5)	.22 x .50 (0.6 x 1.3)	4 (1.8)	PL112700
TB83213	150	1.25	4.92 (12.5)	3.75 (9.5)	3.40 (8.6)	3.13 (8.0)	2.81 (7.1)	.22 x .50 (0.6 x 1.3)	6 (2.7)	PL112701
TB83215	250	2.08	5.38 (13.7)	4.50 (11.4)	3.84 (9.8)	3.75 (9.5)	3.05 (7.7)	.22 x .50 (0.6 x 1.3)	9 (4.1)	PL112702
TB83218	500	4.17	6.06 (15.4)	5.25 (13.3)	4.47 (11.4)	4.06 (10.3)	4.06 (10.3)	.22 x .50 (0.6 x 1.3)	13 (5.9)	PL112704
TB83219	750	6.25	6.43 (16.3)	5.25 (13.3)	4.47 (11.4)	4.38 (11.1)	5.30 (13.0)	.31 x .50 (0.8 x 1.3)	21 (9.5)	PL112704
TB83220	1000	8.33	7.34 (18.6)	6.75 (17.1)	5.78 (14.7)	5.75 (14.6)	3.69 (9.4)	.31 x .50 (0.8 x 1.3)	24 (10.9)	PL112705
TA83221	1500	12.50	8.80 (22.4)	6.75 (17.1)	5.72 (14.5)	5.75 (14.6)	5.02 (12.8)	.31 x .50 (0.8 x 1.3)	43 (19.5)	PL112705
TA83222	2000	16.67	9.15 (23.2)	6.75 (17.1)	5.72 (14.5)	5.75 (14.6)	5.42 (13.8)	.31 x .50 (0.8 x 1.3)	48 (21.8)	PL112705
TA83223	3000	25.00	7.00 (17.8)	7.50 (19.1)	7.66 (19.5)	6.50 (16.5)	5.55 (14.1)	.41 x .81 (1.0 x 2.1)	51 (23.1)	PL112706
TA83224	5000	41.67	7.06 (17.9)	11.92 (30.3)	8.75 (22.2)	6.75 (17.1)	5.75 (14.6)	.41 x .81 (1.0 x 2.1)	90 (40.8)	PL112707

GROUP K

600 PRIMARY VOLTS—120/240 SECONDARY VOLTS—1Ø, 60 Hz

CATALOG NO.	VA RATING	OUTPUT AMPS @ 120V	APPROX. DIMENSIONS INCHES (CM.)						APPROX. SHIP WEIGHT LBS. (KG.)	PRIMARY FUSE BLOCK PART NO.
			A	B	C	D	E	F		
TA-3310	50	0.42	4.13 (10.5)	3.00 (7.6)	2.59 (6.6)	2.50 (6.4)	2.30 (5.8)	.22 x .50 (0.6 x 1.3)	4 (1.8)	PL112700
TA83311	100	0.83	4.90 (12.4)	3.00 (7.6)	2.59 (6.6)	2.50 (6.4)	3.35 (8.5)	.22 x .50 (0.6 x 1.3)	4 (1.8)	PL112700
TA83312	150	1.25	4.92 (12.5)	3.75 (9.5)	3.21 (8.2)	3.13 (8.0)	2.81 (7.1)	.22 x .50 (0.6 x 1.3)	6 (2.7)	PL112701
TA83313	250	2.08	5.38 (13.7)	4.50 (11.4)	3.84 (9.8)	3.75 (9.5)	3.05 (7.7)	.22 x .50 (0.6 x 1.3)	9 (4.1)	PL112702
TA83314	500	4.17	6.06 (15.4)	4.88 (12.4)	4.15 (10.5)	4.06 (10.3)	4.06 (10.3)	.22 x .50 (0.6 x 1.3)	13 (5.9)	PL112703
TA83315	750	6.25	6.43 (16.3)	5.25 (13.3)	4.47 (11.4)	4.38 (11.1)	4.00 (10.2)	.31 x .50 (0.8 x 1.3)	21 (9.5)	PL112704
TA83316	1000	8.33	7.34 (18.6)	6.75 (17.1)	5.72 (14.5)	5.75 (14.6)	3.69 (9.4)	.31 x .50 (0.8 x 1.3)	24 (10.9)	PL112705

* See fusing chart for secondary fuse kits.

TA & TB SERIES PROTECTIVE DEVICES – Primary Fuse Kits

FUSES ARE NOT INCLUDED. CONSULT CATALOG FOR PROPER FUSE SELECTION.

CATALOG NO.	APPROX. SHIP WEIGHT Lbs. (Kg.)
PL112700	1 (0.5)
PL112701	1 (0.5)
PL112702	1 (0.5)
PL112703	1 (0.5)
PL112704	1 (0.5)
PL112705	1 (0.5)
PL112706	1 (0.5)
PL112707	1 (0.5)

TA SERIES PROTECTIVE DEVICES – Secondary Fuse Kits

FOR USE WITH INDUSTRIAL CONTROL TRANSFORMERS THROUGH 1500 VA.

CATALOG NO.	APPROX. SHIP WEIGHT Lbs. (Kg.)
PL112600	0.5 (0.2)
PL112601	0.5 (0.2)
PL112602	1 (0.5)
PL112603	1 (0.5)

TB SERIES PROTECTIVE DEVICES – Secondary Fuse Kits

CATALOG NO.	VA	DESCRIPTION	APPROX. SHIPPING WT. (LBS./KG.)
PL79924		Fuse Kit: Secondary Fuse 1/4" x 1-1/4" w/ARM	1.0 (0.5)
PL79928	50 – 350	Link: Small Jumper Links (Qty. 2)	1.0 (0.5)
PL79929	500 & 750	Link: Large Jumper Links (Qty. 2)	1.0 (0.5)
PL79930	50 – 350	Fuse Kit: Secondary Fuse Midget w/ARM	1.0 (0.5)
PL79931	500 & 1000	Fuse Kit: Secondary Fuse Midget w/ARM	1.0 (0.5)

TA Series Open Core & Coil Wiring Diagrams

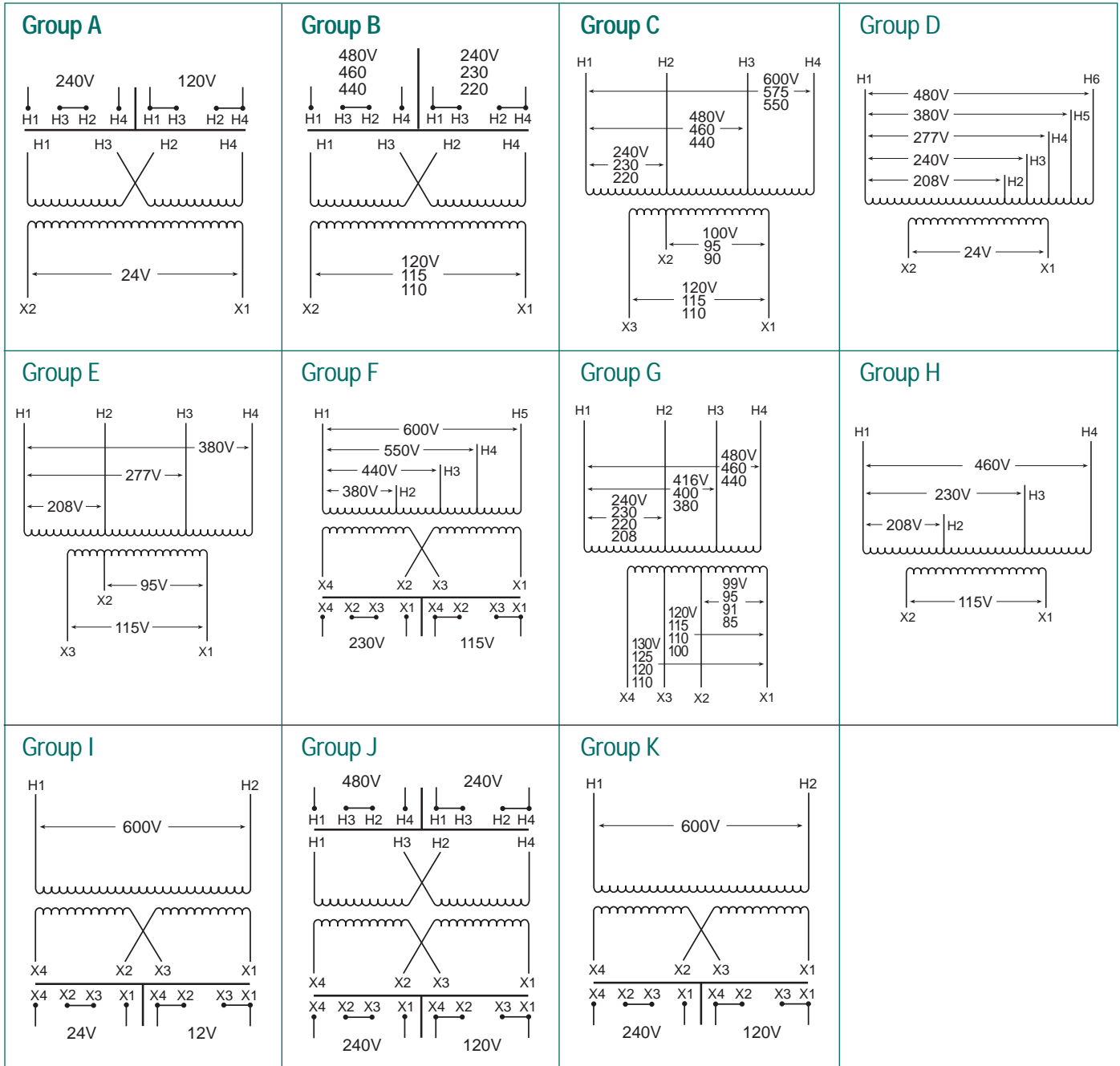

TA Series Open Core & Coil Dimensional Drawings

50 VA Thru 2 kVA

3 & 5 kVA

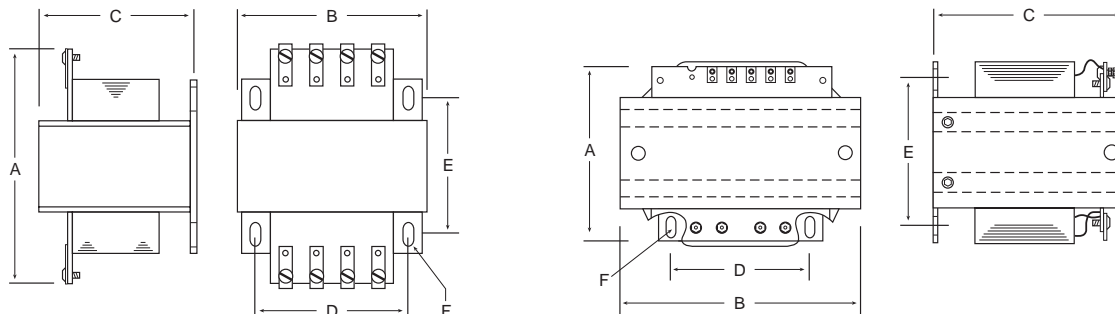

TB Series Open Core & Coil Wiring Diagrams

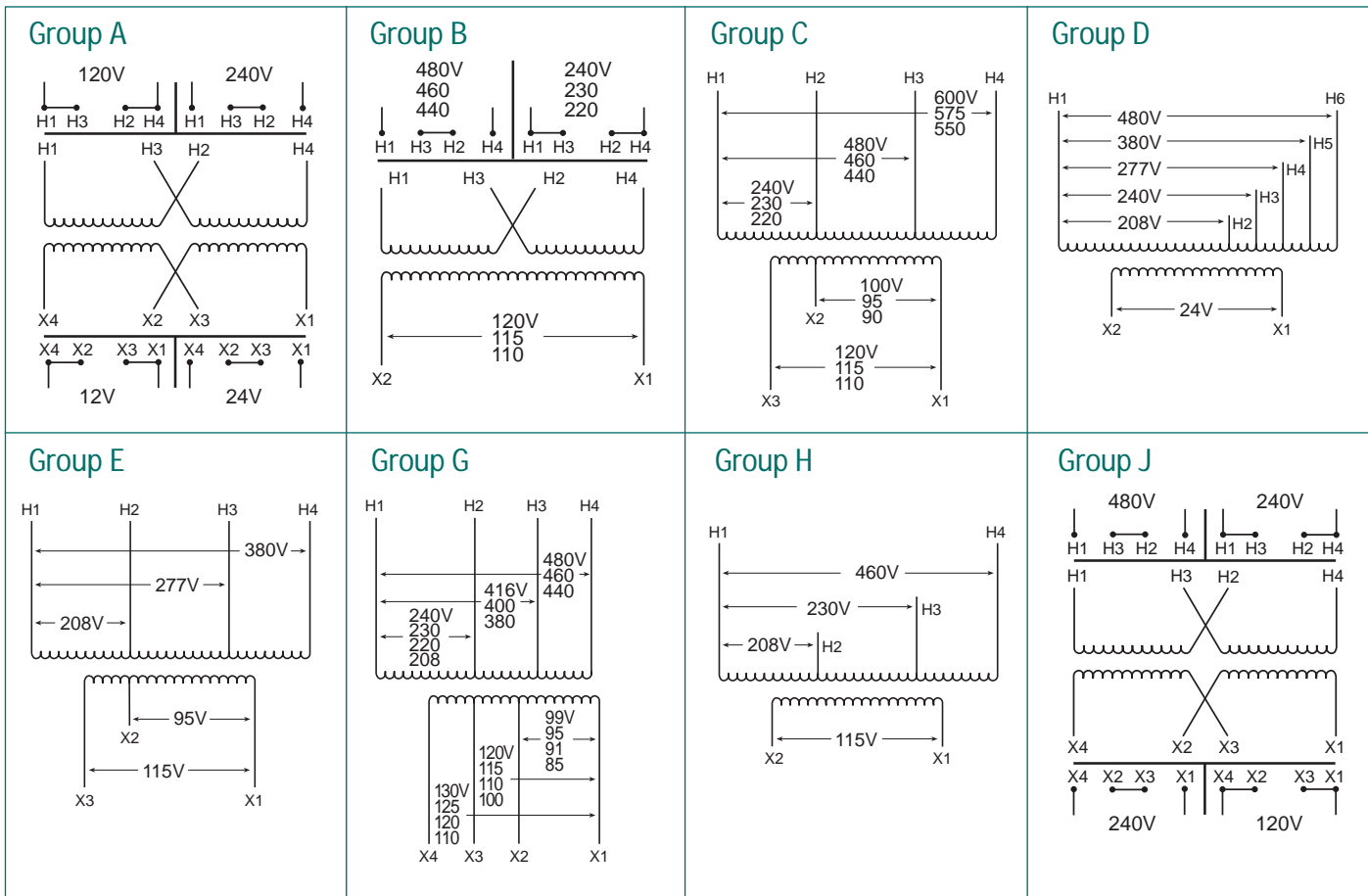

TB Series Open Core & Coil Dimensional Drawings

