

PART NUMBER	ENGINEERING NUMBER	MOUNT OPTION	PLATING	MAT'L.
39-31-1032	5569-03A4-BL	4	BLANK	BL
39-30-3031	5569-03A3	3	BLANK	BLANK
39-30-4039	5569-03A3GS2	3	15 GOLD	
39-30-3033	5569-03A3G	3	30 GOLD	
39-30-3035	5569-03A4	4	BLANK	
39-30-4033	5569-03A4GS2	4	15 GOLD	
39-30-3037	5569-03A4G	4	30 GOLD	BLANK
39-30-3032	5569-03A3-210	3	BLANK	210
39-30-5030	5569-03A3GS2-210	3	15 GOLD	
39-30-3034	5569-03A3G-210	3	30 GOLD	
39-30-3036	5569-03A4-210	4	BLANK	
39-30-4030	5569-03A4G2-210	4	15 GOLD	
39-30-3038	5569-03A4G-210	4	30 GOLD	210
NO E.D.P.	5569-03A5G	5	30 GOLD	BLANK
NO E.D.P.	5569-03A5MS	5	TIN/NICKEL	BLANK
NO E.D.P.	5569-03A5G-210	5	30 GOLD	210
39-34-3037	5569-03A5MS-210	5	TIN/NICKEL	210

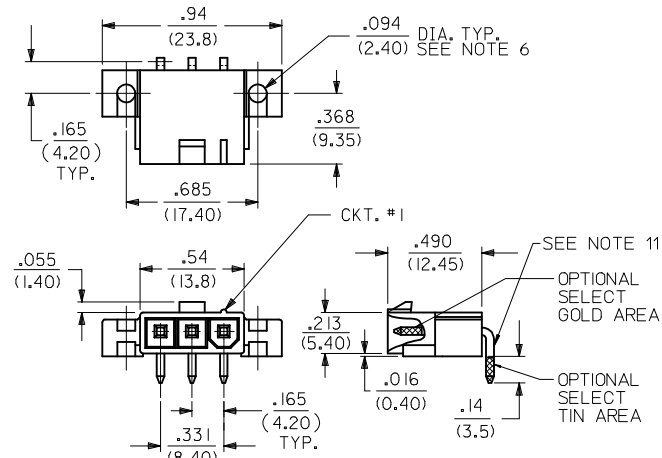

RIGHT ANGLE HEADER
(SCREW MOUNT)

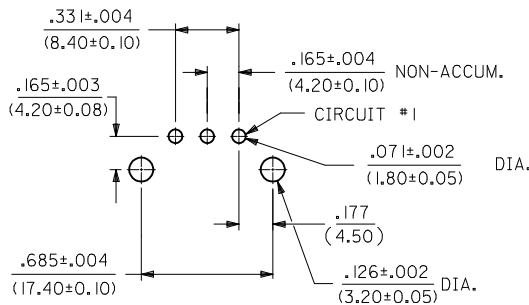

RECOMMENDED HOLE LAYOUT FOR
.070/(1.78) MAX. THICK P.C. BOARD
VIEWED FROM COMPONENT SIDE

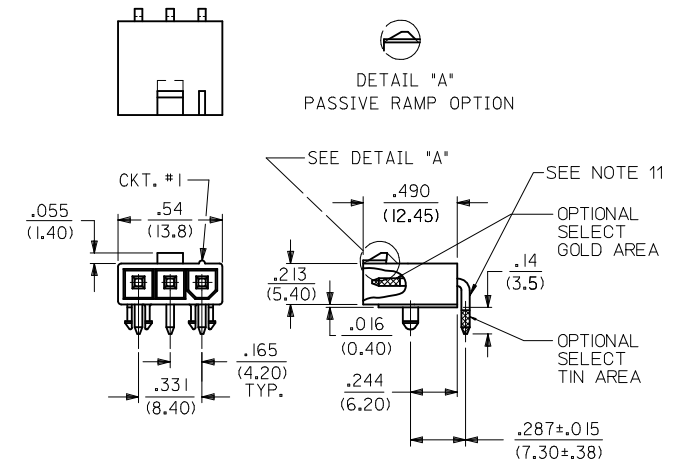

RIGHT ANGLE HEADER
(PEG MOUNT)

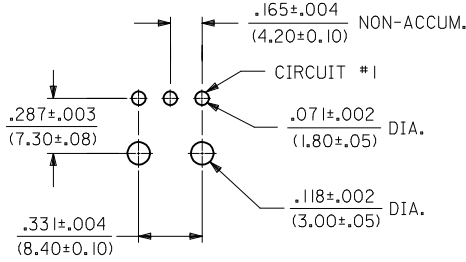

RECOMMENDED HOLE LAYOUT FOR
.070/(1.78) MAX. THICK P.C. BOARD
VIEWED FROM COMPONENT SIDE

NOTES:

- HOUSING MATERIAL:
"BLANK" = NYLON 6/6, U.L. 94V-2, COLOR: NATURAL.
210 = NYLON 6/6, U.L. 94V-0, COLOR: NATURAL.
BL = NYLON 6/6, U.L. 94V-2, COLOR: BLACK.
TERMINAL MATERIAL: BRASS, ALLOY
- TERMINAL PLATING:
"BLANK", MS - .000100/(0.00254) MIN. MATTE TIN OVER
.000050/(0.00127) MIN. NICKEL
G - .000030/(.00076) MIN. SELECT GOLD, .000100/(.00254) MIN. SELECT MATTE TIN OVER .000050/(.00127) MIN. NICKEL OVERALL.
G2,GS2 - .000015/(.00038) MIN. SELECT GOLD, .000100/(.00254) MIN. SELECT MATTE TIN OVER .000050/(.00127) MIN. NICKEL OVERALL.
- PRODUCT SPECIFICATION: PS-5556-001
- PACKAGING SPECIFICATION: PK-5569-002
- PART MATES WITH MOLEX RECEPTACLE #5557.
- PART IS DESIGNED FOR USE WITH #4 OR M3 SELF TAPPING SCREWS.
- DISCOLORATION IN THE BANDOLIER CARRIER AREA OF THE PIN IS INHERENT TO THE PLATING PROCESS AND IS DUE TO THE MASKING EFFECT OF THE CARRIER. THIS DISCOLORATION IS IN A NON-FUNCTIONAL AREA OF THE PIN AND WILL NOT AFFECT THE PERFORMANCE OF THE HEADER ASSEMBLY.
- CONNECTORS ARE NOT BE MATED OR UNMATED WHILE CIRCUITS ARE LIVE.
- PARTS ARE NOT DESIGNED FOR CURRENT SHARING.
- PART CONFORMS TO CLASS "B" REQUIREMENTS OF "COSMETIC SPECIFICATION PS-45499-002."
- FORMING MARKS ON PINS ARE ACCEPTABLE

LEGEND

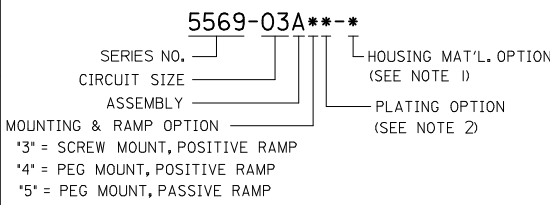

CHG DIM 3.6 TO 3.5 EC NO: UCP2013-4208 DRW: NANGUYEN 2014/04/11 CHKD: JIBELL 2014/04/11 APPR: FSM/TH 2014/05/16 REV: S3	QUALITY SYMBOLS	GENERAL TOLERANCES (UNLESS SPECIFIED)	DIMENSION STYLE IN/MM	SCALE METRIC	DESIGN UNITS METRIC	THIRD ANGLE PROJECTION
	▽=0	4 PLACES ± --- ± ---	DRAWN BY GEP	DATE 9/20/90	TITLE RIGHT ANGLE HEADER ASSY, 3 CKT., SINGLE ROW, MINI-FIT JR. SERIES	molex DOCUMENT NO. SDA-5569-03A** SHEET NO. 1 OF 1
	▽=0	3 PLACES ± --- ± .010	CHECKED BY RJF	DATE 9/20/90		
	▽=0	2 PLACES ± 0.25 ± .015	APPROVED BY FSM/TH	DATE 2014/05/16		
▽=0	1 PLACE ± 0.38 ± ---	0 PLACE ± --- ± ---	MATERIAL NO. SEE CHART SIZE C			
DRAFT WHERE APPLICABLE MUST REMAIN WITHIN DIMENSIONS		ANGULAR ± 3°				