

# Direct Air Operated 2 Port Valve Series VXA21/22

For Air, Water, Oil

VX2  
VXK  
VXD  
VXZ  
VXS  
VXE  
VXP  
VXR  
VXH  
VXF2  
VX3  
VXA



## Single Unit

Normally closed (N.C.)

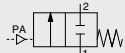

Normally open (N.O.)

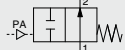

### Valve

### Pilot port (Free take off direction)

Port size — Rc $\frac{1}{8}$

Pilot pressure — 0.25 to 0.7 MPa

### Material

Body — Brass (C37), Stainless steel  
Seal — NBR, FKM, EPDM

### Model

Model	Port size Rc	Orifice dia. (mmø)
VXA212 $\frac{2}{8}$	1/8, 1/4	3
VXA213 $\frac{3}{8}$	1/8, 1/4	4.5
VXA223 $\frac{3}{8}$	1/4, 3/8	4.5
VXA224 $\frac{4}{8}$	1/4, 3/8	6
VXA225 $\frac{5}{8}$	1/4, 3/8	8
VXA226 $\frac{6}{8}$	1/4, 3/8, 1/2	10



## Manifold

Normally closed (N.C.)

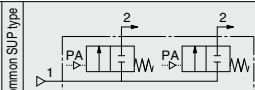

Normally open (N.O.)

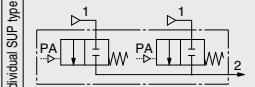

### Valve

### Material

Base — AL  
Body — Zn  
Seal — NBR, FKM, EPDM

Normally open (N.O.)

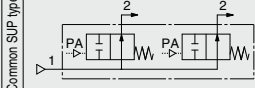

### Manifold

Manifold system — B mount  
Manifold station — 2 to 10 station

### Model

Manifold base	Individual port Rc	Common port Rc
VVXA211-station	1/8	3/8
VVXA212-station	1/4	
VVXA221-station	1/8	3/8
VVXA222-station	1/4	

# Common Specifications

## Standard Specifications

Valve specifications	Type		Single Unit	Manifold
	Valve construction		Pilot operated poppet	
	Withstand pressure	MPa	1.5	
	Body material		Brass (C37), Stainless steel	Zn
	Seal material		NBR, FKM, EPDM	NBR, FKM, EPDM

## Contents

For Air /Single Unit .....	P.338
For Air /Manifold .....	P.340
For Water /Single Unit .....	P.342
For Oil /Single Unit .....	P.344
For Oil /Manifold .....	P.346
Construction: Single Unit .....	P.348
Construction: Manifold .....	P.349
Dimensions: Single Unit .....	P.350
Dimensions: Manifold .....	P.351

# Direct Air Operated 2 Port Valve

## Series VXA21/22

# Applicable Fluid Check List

**All Options (Single Unit)** Refer to page for specifications and models.

VXA2   <sup>0</sup>/<sub>2</sub>  -   - 1 -

Option symbol

Fluid and application	Option symbol	Seal material	Body material	Holder material (drive part)
Air	Nil	NBR	Brass (C37)	PPS
	G		Stainless steel	
Medium vacuum (0.1 Pa-abs), Non-leak <sup>Note 1)</sup>	V <sup>Note 2)</sup>	FKM	Brass (C37)	
	M <sup>Note 2)</sup>		Stainless steel	
Water	Nil	NBR	Brass (C37)	
	G		Stainless steel	
Oil <sup>Note 3)</sup>	A	FKM	Brass (C37)	
	H		Stainless steel	
Other combination	B	EPDM	Brass (C37)	
	J		Stainless steel	



VX2

VXK

VXD

VXZ

VXS

VXE

VXP

VXR

VXH

VXF2

VX3

VXA

**All Options (Manifold)** Refer to pages 210 and 216 for specifications and models.

VXA2   <sup>1</sup>/<sub>3</sub>  - 00 - 1

Option symbol

Fluid and application	Option symbol	Seal material	Body material	Holder material (drive part)
Air	Nil	NBR	Zn	PPS
Medium vacuum, Non-leak <sup>Note 1)</sup>	V <sup>Note 2)</sup>	FKM		
Oil <sup>Note 3)</sup>	A	FKM		
Other combination	B	EPDM		

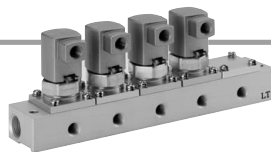

Note 1) The leakage amount (10<sup>-4</sup> Pa·m<sup>3</sup>/s) of "V" options are values when differential pressure is 0.1 MPa.

Note 2) Use grease for vacuums on sliding parts. Use silicon grease elsewhere.

Note 3) The dynamic viscosity of the fluid must not exceed 50 mm<sup>2</sup>/s or less.

\* If using for other fluids, please consult with SMC.

\* Oil-free specification: Oil-free specification cannot be manufactured since the sliding parts in contact with fluid have a seal construction.

## For Air /Single Unit

(Inert gas, Non-leak, Medium vacuum)

### Model/Valve Specifications

N.C.

N.O.

Symbol

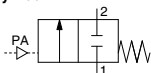

Symbol

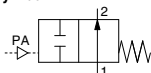

### Model/Valve

Port size	Orifice diameter (mm)	Model	Max. operating pressure differential (MPa)	Pilot pressure (MPa)	Flow characteristics			Max. system pressure (MPa)	Proof pressure (MPa)	Weight (g)
					Air					
					C[dm <sup>3</sup> /(s·bar)]	b	Cv			
1/8 (6A)	3	VXA212 $\frac{3}{2}$	1.0	0.25 to 0.7	1.3	0.50	0.38	1.0	1.5	170
	4.5	VXA213 $\frac{3}{2}$	0.5		2.3	0.45	0.70			
1/4 (8A)	3	VXA212 $\frac{3}{2}$	1.0		1.3	0.50	0.38			
	4.5	VXA213 $\frac{3}{2}$	0.5		2.5	0.45	0.75			
	6	VXA224 $\frac{3}{2}$	1.0		3.3	0.50	1.1			
	8	VXA225 $\frac{3}{2}$	0.2		6.4	0.40	1.8			
	10	VXA226 $\frac{3}{2}$	0.1		8.8	0.40	2.3			
	4.5	VXA223 $\frac{3}{2}$	1.0		2.5	0.45	0.75			
3/8 (10A)	6	VXA224 $\frac{3}{2}$	0.6		3.3	0.50	1.1	1.0	250	340
	8	VXA225 $\frac{3}{2}$	0.2		6.4	0.40	1.8			
	10	VXA226 $\frac{3}{2}$	0.1		11.0	0.38	2.8	0.4	340	
	1/2 (15A)	10	VXA226 $\frac{3}{2}$		0.1	11.0	0.38			2.8

• Refer to "Glossary of Terms" on page 241 for details on the max. operating pressure differential and the max. system pressure.

### Fluid and Ambient Temperature

Fluid temperature (°C)		Ambient temperature (°C)
Valve option symbol		
Nil, Others	V, M	
-5 <sup>Note</sup> to 60	-5 <sup>Note</sup> to 40	-5 to 40

Note) Dew point temperature: -5°C or less

### Valve Leakage Rate

#### Internal Leakage

Seal material	Leakage rate	
	Air	Non-leak <sup>Note</sup> Medium vacuum
NBR, EPDM, FKM	1 cm <sup>3</sup> /min or less	10 <sup>-6</sup> Pa·m <sup>3</sup> /sec or less

#### External Leakage

Seal material	Leakage rate	
	Air	Non-leak <sup>Note</sup> Medium vacuum
NBR, EPDM, FKM	1 cm <sup>3</sup> /min or less	10 <sup>-6</sup> Pa·m <sup>3</sup> /sec or less

Note) Value for option "V", "M" (Non-leak, Medium vacuum)

### How to Order (Single Unit)

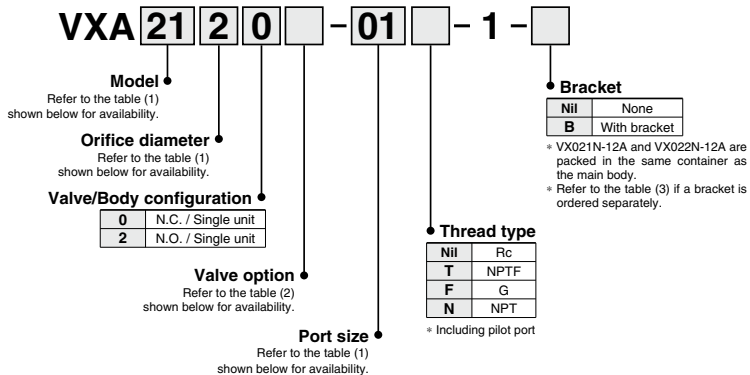

**Table (1) Model/Orifice Diameter/Port Size**

Solenoid valve (Port size)		Orifice symbol (Diameter)					
Model	VXA21	VXA22	2 (3 mmø)	3 (4.5 mmø)	4 (6 mmø)	5 (8 mmø)	6 (10 mmø)
Port no. (Port size)	01 (1/8)	—	●	●	—	—	—
	02 (1/4)	—	●	●	—	—	—
	—	02 (1/4)	—	●	●	●	●
	—	03 (3/8)	—	●	●	●	●
	—	04 (1/2)	—	—	—	—	●

**Table (2) Valve Option**

Option symbol	Seal material	Body material	Holder material	Note
Nil	NBR	Brass (C37)	PPS	—
G		Stainless steel		
V (Note)	FKM	Brass (C37)		
M (Note)		Stainless steel		

Note) Use grease for vacuums on sliding parts. Use silicon grease elsewhere.

**Table (3) Bracket Part No.**

Model	Part no.
VXA21 <sup>20</sup> <sub>32</sub>	VX021N-12A
VXA22 <sup>32</sup> <sub>62</sub>	VX022N-12A
VXA22 <sup>50</sup> <sub>62</sub>	VX023N-12A-L

VX2  
VXK  
VXD  
VXZ  
VXS  
VXE  
VXP  
VXR  
VXH  
VXF2  
VX3  
VXA

# Series VVXA21/22

## For Air /Manifold

(Inert gas, Non-leak, Medium vacuum)

### Model for Manifold/Valve Specifications

N.C.

Symbol

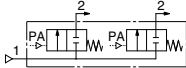

Common SUP type

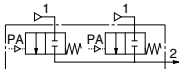

Individual SUP type

N.O.

Symbol

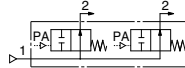

Common SUP type

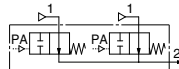

Individual SUP type



### Model for Manifold/Valve Specifications

Orifice diameter (mm)	Model	Max. operating pressure differential (MPa)	Pilot pressure (MPa)	Flow characteristics			Max. system pressure (MPa)	Proof pressure (MPa)	Weight (g) <sup>Note)</sup>
				Air					
				C <sub>d</sub> [dm <sup>3</sup> /(s·bar)]	b	C <sub>v</sub>			
3	VXA212 $\frac{1}{2}$ -00	1.0	0.25 to 0.7	1.3	0.50	0.38	1.0	1.5	120
	VXA213 $\frac{1}{2}$ -00	0.5		2.3	0.45	0.70			
4.5	VXA223 $\frac{1}{2}$ -00	1.0		3.3	0.50	1.1			
6	VXA224 $\frac{1}{2}$ -00	0.6							

• Refer to "Glossary of Terms" on page 241 for details on the max. operating pressure differential and the max. system pressure.

### Fluid and Ambient Temperature

Fluid temperature (°C)		Ambient temperature (°C)
Solenoid valve option symbol		
NII, A, B	V	
-5 <sup>Note)</sup> to 60	-5 <sup>Note)</sup> to 40	-5 to 40

Note) Dew point temperature: -5°C or less

### Valve Leakage Rate

#### Internal Leakage

Seal material	Leakage rate	
	Air	Non-leak <sup>Note)</sup> Medium vacuum
NBR, EPDM, FKM	1 cm <sup>3</sup> /min or less	10 <sup>-6</sup> Pa·m <sup>3</sup> /sec or less

#### External Leakage

Seal material	Leakage rate	
	Air	Non-leak <sup>Note)</sup> Medium vacuum
NBR, EPDM, FKM	1 cm <sup>3</sup> /min or less	10 <sup>-6</sup> Pa·m <sup>3</sup> /sec or less

Note) Value for option "V" (Non-leak, Medium vacuum)

### How to Order (Valve for Manifold)

VXA **21** **2** **1**  - **00** - **1**

- Model**  
Refer to the table (1) shown below for availability.
- Orifice diameter**  
Refer to the table (1) shown below for availability.
- Valve option**  
Refer to the table (2) shown below for availability.
- Valve/Body configuration**

1	N.C. (For manifold)
3	N.O. (For manifold)

### How to Order Manifold Bases

VVXA21  
VVXA22 **1**  - **07** - **1**

- Port size (Individual port)**
- Number of manifolds**
- Base**
- Manifold base**

1	Rc 1/8
2	Rc 1/4

\* All IN ports are Rc 3/8.

02	2 stations
:	:
10	10 stations

Nil	Common SUP type
V	Individual SUP type

**Table (1) Model/Orifice Diameter**

Solenoid valve	Orifice symbol (Diameter)		
	2 (3 mmφ)	3 (4.5 mmφ)	4 (6 mmφ)
VXA21	●	●	—
VXA22	—	●	●

**Table (2) Valve Option**

Option symbol	Body material	Base material	Seal material	Holder material	Note
Nil	Zn	AL	NBR	PPS	—
A			FKM		
B			EPDM		
V <sup>(Note)</sup>			FKM		
					Non-leak (10 <sup>-6</sup> Pam <sup>3</sup> /sec), Medium vacuum (0.1 Pa.abs)

Note) Use grease for vacuums on sliding parts. Use silicon grease elsewhere.

● Blanking plate part no.

For VXA21: VX011-001   
 For VXA22: VX011-006

● Seal material

N	NBR
F	FKM
E	EPDM

### How to Order Manifold

■ Write both the base part number and the solenoid valve to be mounted or blanking plate part number.  
 (Example) 7 stations of VXA21 common pressure, individual port Rc 1/8.

(Base) VVXA211-07-1 ..... 1 pc.  
 (Valve) \* VXA2121-00-1 ..... 6 pcs.  
 (Blanking plate) \* VX011-001N ..... 1 pc.

\*" is the symbol for mounting. When shipping mounted on a base, add an "\*" in front of the valve and blanking plate model.

■ Arrangement of solenoid valves

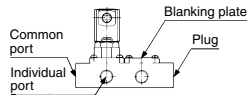

The standard arrangement of manifolds should be placed on an individual port on this side, each solenoid valve from the left side and a blank plate in the right side. The right side of the common port provides plug.

- VX2
- VXK
- VXD
- VXZ
- VXS
- VXE
- VXP
- VXR
- VXH
- VXF2
- VX3
- VXA

# Series VXA21/22

## For Water /Single Unit

### Model/Valve Specifications

N.C.

N.O.

Symbol

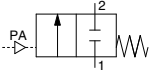

Symbol

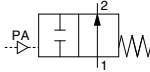

### Model/Valve Specifications

Port size	Orifice diameter (mm)	Model	Pilot pressure (MPa)	Max. operating pressure differential (MPa)	Flow characteristics		Max. system pressure (MPa)	Proof pressure (MPa)	Weight (g)			
					Water							
					Av x 10 <sup>-6</sup> m <sup>2</sup>	Cv converted						
1/8 (6A)	3	VXA212 $\frac{1}{2}$	0.25 to 0.7	1.0	7.9	0.33	1.0	1.5	170			
	4.5	VXA213 $\frac{1}{2}$		0.5	15	0.61						
1/4 (8A)	3	VXA212 $\frac{1}{2}$		1.0	7.9	0.33				0.4	1.5	250
	4.5	VXA213 $\frac{1}{2}$		0.5	15	0.61						
	6	VXA224 $\frac{1}{2}$		0.6	26	1.1						
	8	VXA225 $\frac{1}{2}$		0.2	41	1.7						
	10	VXA226 $\frac{1}{2}$		0.1	46	1.9						
	4.5	VXA223 $\frac{1}{2}$		1.0	15	0.61						
3/8 (10A)	6	VXA224 $\frac{1}{2}$		0.6	26	1.1	1.0	1.5	250			
	8	VXA225 $\frac{1}{2}$		0.2	41	1.7						
	10	VXA226 $\frac{1}{2}$		0.1	58	2.4						
	1/2 (15A)	10		VXA226 $\frac{1}{2}$	0.1	58				2.4	0.4	1.5
								420				

• Refer to "Glossary of Terms" on page 241 for details on the max. operating pressure differential and the max. system pressure.

### Fluid and Ambient Temperature

Fluid temperature (°C)	Ambient temperature (°C)
Valve option symbol	
<b>N, G, B, J</b>	
1 to 40	-5 to 40

Note) With no freezing

### Valve Leakage Rate

#### Internal Leakage

Seal material	Leakage rate (Water)
NBR, EPDM	0.1 cm <sup>3</sup> /min or less

#### External Leakage

Seal material	Leakage rate (Water)
NBR, EPDM	0.1 cm <sup>3</sup> /min or less



### How to Order (Single Unit)

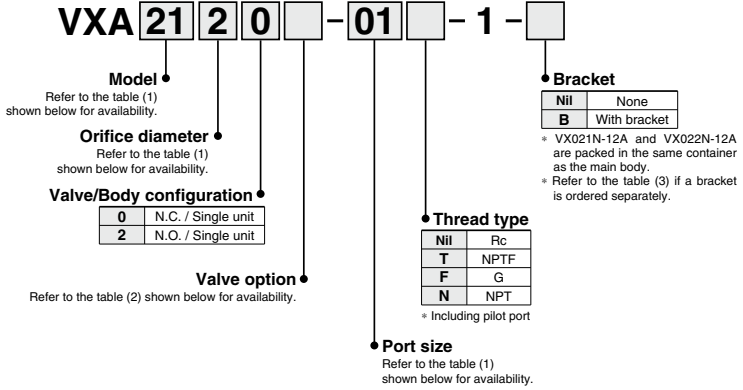

**Table (1) Model/Orifice Diameter/Port Size**

Model	Valve (Port size)		Orifice symbol (Diameter)				
	VX21	VX22	2 (3 mmø)	3 (4.5 mmø)	4 (6 mmø)	5 (8 mmø)	6 (10 mmø)
Port no. (Port size)	01 (1/8)	—	●	●	—	—	—
	—	—	●	●	—	—	—
	—	02 (1/4)	—	●	●	●	●
	—	03 (3/8)	—	●	●	●	●
	—	04 (1/2)	—	—	—	—	●

**Table (2) Valve Option**

Option symbol	Seal material	Body material	Holder material	Note
Nil	NBR	Brass (C37)	PPS	—
G		Stainless steel		
B	EPDM	Brass (C37)		
J		Stainless steel		

**Table (3) Bracket Part No.**

Model	Part no.
VX21 <sup>20</sup> <sub>32</sub>	VX021N-12A
VX22 <sup>30</sup> <sub>42</sub>	VX022N-12A
VX22 <sup>50</sup> <sub>62</sub>	VX023N-12A-L

- VX2
- VXK
- VXD
- VXZ
- VXS
- VXE
- VXP
- VXR
- VXH
- VXF2
- VX3
- VXA

# Series VXA21/22

## For Oil /Single Unit

### Model/Valve Specifications

N.C.

N.O.

Symbol

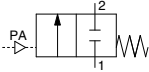

Symbol

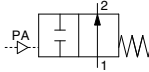

**⚠ When the fluid is oil.**

The dynamic viscosity of the fluid must not exceed 500 mm<sup>2</sup>/s.



### Model/Valve Specifications

Port size	Orifice diameter (mm)	Model	Max. operating pressure differential (MPa)	Pilot pressure (MPa)	Flow characteristics		Max. system pressure (MPa)	Proof pressure (MPa)	Weight (g)
					Oil				
					Av x 10 <sup>-6</sup> m <sup>2</sup>	Cv converted			
1/8 (6A)	3	VXA212 $\frac{1}{2}$	1.0	0.25 to 0.7	7.9	0.33	1.0	1.5	170
	4.5	VXA213 $\frac{1}{2}$	0.5		15	0.61			
1/4 (8A)	3	VXA212 $\frac{1}{2}$	1.0		7.9	0.33			
	4.5	VXA213 $\frac{1}{2}$	0.5		15	0.61			
	6	VXA224 $\frac{1}{2}$	0.6		26	1.1			
	8	VXA225 $\frac{1}{2}$	0.2		41	1.7			
	10	VXA226 $\frac{1}{2}$	0.1		46	1.9			
	4.5	VXA223 $\frac{1}{2}$	1.0		15	0.61			
3/8 (10A)	6	VXA224 $\frac{1}{2}$	0.6		26	1.1	0.4	1.5	250
	8	VXA225 $\frac{1}{2}$	0.2		41	1.7			
	10	VXA226 $\frac{1}{2}$	0.1		58	2.4			
1/2 (15A)	10	VXA226 $\frac{1}{2}$	0.1		58	2.4	0.4	1.5	340

• Refer to "Glossary of Terms" on page 241 for details on the max. operating pressure differential and the max. system pressure.

### Fluid and Ambient Temperature

Fluid temperature (°C)	Ambient temperature (°C)
Valve option symbol	
<b>A, H</b>	
-5 <sup>Note1</sup> to 40	-5 to 40

Note) Dynamic viscosity: 500 mm<sup>2</sup>/s or less

### Valve Leakage Rate

#### Internal Leakage

Seal material	Leakage rate (Oil)
FKM	0.1 cm <sup>3</sup> /min or less

#### External Leakage

Seal material	Leakage rate (Oil)
FKM	0.1 cm <sup>3</sup> /min or less

### How to Order (Single Unit)

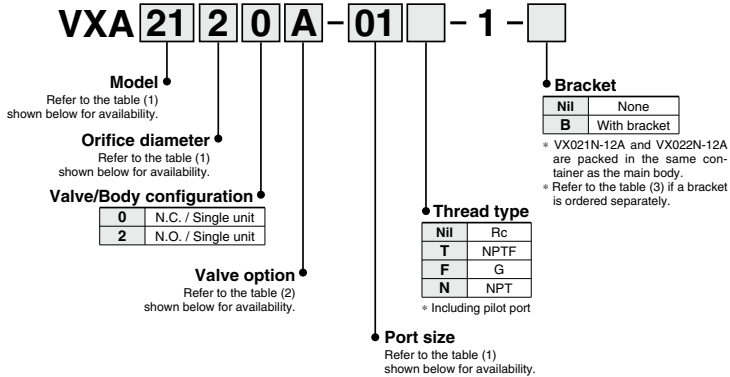

**Table (1) Model/Orifice Diameter/Port Size**

Solenoid valve (Port size)		Orifice symbol (Diameter)					
Model	VX21	VX22	2 (3 mmø)	3 (4.5 mmø)	4 (6 mmø)	5 (8 mmø)	6 (10 mmø)
Port no. (Port size)	01 (1/8)	—	●	●	—	—	—
	02 (1/4)	—	●	●	—	—	—
	—	02 (1/4)	—	●	●	●	●
	—	03 (3/8)	—	●	●	●	●
	—	04 (1/2)	—	—	—	—	●

**Table (2) Valve Option**

Option symbol	Seal material	Body material	Holder material
A	FKM	Brass (C37)	PPS
H		Stainless steel	

The additives contained in oil are different depending on the type and manufacturers, so the durability of seal materials will vary. For details, please consult with SMC.

**Table (3) Bracket Part No.**

Model	Part no.
VX21 <sup>20</sup> / <sub>32</sub>	VX021N-12A
VX22 <sup>30</sup> / <sub>42</sub>	VX022N-12A
VX22 <sup>30</sup> / <sub>62</sub>	VX023N-12A-L

# Series VVXA21/22

## For Oil /Manifold

### Valve for Manifold/Valve Specifications

N.C.

Symbol

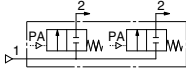

Common SUP type

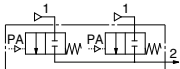

Individual SUP type

### Valve for Manifold/Valve Specifications

Orifice diameter (mm)	Model	Max. operating pressure differential (MPa)	Pilot pressure (MPa)	Flow characteristics		Max. system pressure (MPa)	Proof pressure (MPa)	Weight (g) <small>(Note)</small>
				Air				
				$Av \times 10^{-6} \text{ m}^3/\text{Cv converted}$				
3	VXA2123-00	1.0	0.25 to 0.7	7.9	0.33	1.0	1.5	120
	VXA2133-00	0.5		15	0.61			
4.5	VXA2233-00	1.0		26	1.1			
6	VXA2243-00	0.6						

• Refer to "Glossary of Terms" on page 241 for details on the max. operating pressure differential and the max. system pressure.

### Fluid and Ambient Temperature

Fluid temperature (°C)	Ambient temperature (°C)
Valve option symbol	
<b>A</b>	
-5 <small>(Note)</small> to 40	-5 to 40

Note) Dynamic viscosity: 500 mm<sup>2</sup>/s or less

**⚠ When the fluid is oil.**

The dynamic viscosity of the fluid must not exceed 500 mm<sup>2</sup>/s.

N.O.

Symbol

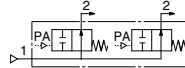

Common SUP type

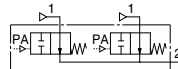

Individual SUP type



### Valve Leakage Rate

#### Internal Leakage

Seal material	Leakage rate
FKM	0.1 cm <sup>3</sup> /min or less

#### External Leakage

Seal material	Leakage rate
FKM	0.1 cm <sup>3</sup> /min or less

### How to Order (Valve for Manifold)

VXA **21** **2** **1** **A** - 00 - 1

- Model**  
Refer to the table (1) shown below for availability.
- Orifice diameter**  
Refer to the table (1) shown below for availability.
- Valve option**  
Refer to the table (2) shown below for availability.
- Valve/Body configuration**

1	N.C. (For manifold)
3	N.O. (For manifold)

### How to Order Manifold Bases

VVXA21  
VVXA22

- 1** **2** - **07** - 1
- Port size (Individual port)**

1	Rc 1/8
2	Rc 1/4

\* All IN ports are Rc 3/8.
  - Number of manifolds**

02	2 stations
:	:
10	10 stations
  - Base**

Nil	Common SUP type
V	individual SUP type

Table (1) Model/Orifice Diameter

Solenoid valve	Orifice symbol (Diameter)		
	2 (3 mmø)	3 (4.5 mmø)	4 (6 mmø)
VXA21	●	●	—
VXA22	—	●	●

Table (2) Valve Option

Option symbol	Body, Base material	Seal material	Holder material	Note
A	Aluminum	FKM	PPS	—

Manifold base

Blanking plate part no.

For VXA21: VX011-001 F  
For VXA22: VX011-006 F

- Seal material**

F	FKM
---	-----

### How to Order Manifold

Write both the base part number and the solenoid valve to be mounted or blanking plate part number.  
(Example) 7 stations of VXA21 common pressure, individual port Rc 1/8.

(Base) VVXA211-07-1 ..... 1 pc.  
(Valve) = VXA2121-00-1 ..... 6 pcs.  
(Blanking plate) = VX011-001F ..... 1 pc.

"s" is the symbol for mounting. When shipping mounted on a base, add an "s" in front of the valve and blanking plate model.

Arrangement of solenoid valves

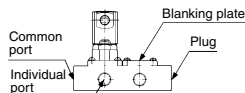

The standard arrangement of manifolds should be placed on an individual port on this side, each solenoid valve from the left side and a blank plate on the right side. The right side of the common port provides plug.

- VX2
- VXK
- VXD
- VXZ
- VXS
- VXE
- VXP
- VXR
- VXH
- VXF2
- VX3
- VXA

# Series VXA21/22

For Air, Water, Oil

## Construction: Single Unit

Normally closed (N.C.)

Body material: Brass (C37), Stainless steel

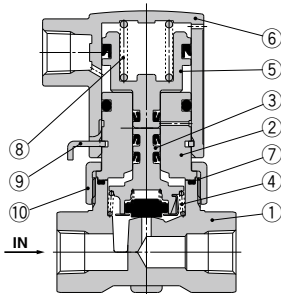

### Component Parts

No.	Description	Material	
		Body material Brass (C37) specification	Body material stainless steel specification
1	Body	Brass (C37)	Stainless steel
2	Adapter	C36	Stainless steel
3	Holder assembly	(NBR, FKM, EPDM), Stainless steel, PPS	
4	Return spring	Stainless steel	
5	Piston assembly	(NBR), Polyacetal	
6	Pilot cover	ADC12	
7	O-ring	(NBR, FKM, EPDM)	
8	Piston spring	Stainless steel	
9	Retainer	Stainless steel	
10	Nut	Brass (C37)	Brass (C37), Ni plated

The materials in parentheses are the seal materials.

Normally open (N.O.)

Body material: Brass (C37), Stainless steel

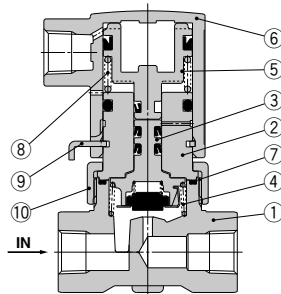

### Component Parts

No.	Description	Material	
		Body material Brass (C37) specification	Body material stainless steel specification
1	Body	Brass (C37)	Stainless steel
2	Adapter	C36	Stainless steel
3	Holder assembly	(NBR, FKM, EPDM), Stainless steel, PPS	
4	Return spring	Stainless steel	
5	Piston assembly	(NBR), Polyacetal	
6	Pilot cover	ADC12	
7	O-ring	(NBR, FKM, EPDM)	
8	Piston spring	Stainless steel	
9	Retainer	Stainless steel	
10	Nut	Brass (C37)	Brass (C37), Ni plated

The materials in parentheses are the seal materials.

### Construction: Manifold

**Normally closed (N.C.)**

**Body material: Zn**

**Base material: AL**

**Normally open (N.O.)**

**Body material: Zn**

**Base material: AL**

Common SUP type

Individual SUP type

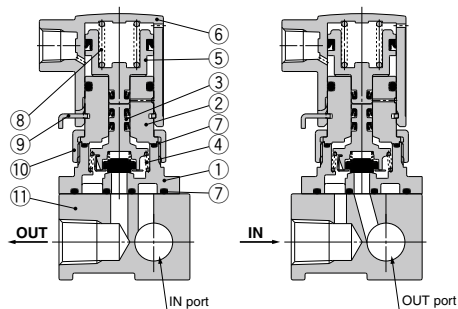

Common SUP type

Individual SUP type

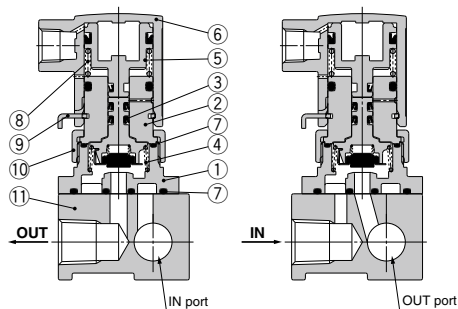

#### Component Parts

No.	Description	Material
1	Body	Zn
2	Adapter	C36
3	Holder assembly	(NBR, FKM, EPDM), Stainless steel, PPS
4	Return spring	Stainless steel
5	Piston assembly	NBR, Polyacetal
6	Pilot cover	ADC12
7	O-ring	(NBR, FKM, EPDM)
8	Piston spring	Stainless steel
9	Retainer	Stainless steel
10	Nut	Brass (C37)
11	Base	Aluminum

The materials in parentheses are the seal materials.

#### Component Parts

No.	Description	Material
1	Body	Zn
2	Adapter	C36
3	Holder assembly	(NBR, FKM, EPDM), Stainless steel, PPS
4	Return spring	Stainless steel
5	Piston assembly	NBR, Polyacetal
6	Pilot cover	ADC12
7	O-ring	(NBR, FKM, EPDM)
8	Piston spring	Stainless steel
9	Retainer	Stainless steel
10	Nut	Brass (C37)
11	Base	Aluminum

The materials in parentheses are the seal materials.

VX2

VXK

VXD

VXZ

VXS

VXE

VXP

VXR

VXH

VXF2

VX3

VXA

# Series VXA21/22

For Air, Vacuum, Water, Oil

## Dimensions: Single Unit/Body Material: Brass (C37), Stainless Steel

Normally closed (N.C.): VXA21□0/VXA22□0

Normally open (N.O.): VXA21□2/VXA22□2

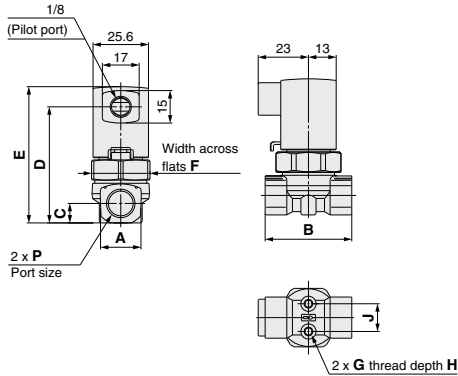

Model		Orifice diameter	Port size P	A	B	C	D	E	F	G	H	J
N.C.	N.O.											
VXA21□0	VXA21□2	ø3, ø4.5	1/8, 1/4	19	40	9	54	63	27	M4	6	12.8
VXA22(3,4)0	VXA22(3,4)2	ø4.5, ø6	1/4, 3/8	22	45	10.5	60	69	32	M5	8	19
VXA22(5,6)0	VXA22(5,6)2	ø8, ø10	1/4, 3/8, 1/2	29	50	14	66	76	32	M5	8	23

(mm)

### Specifications with bracket

Orifice ø3, ø4.5, ø6

Orifice ø8, ø10

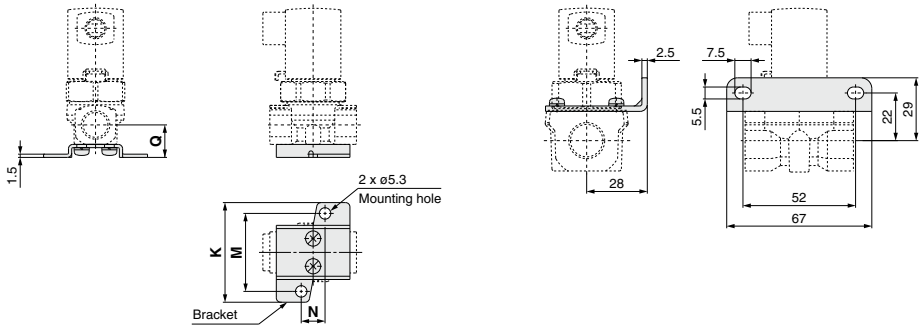

Model		Orifice diameter	Port size P	Bracket mounting			
N.C.	N.O.			K	M	N	Q
VXA21□0	VXA21□2	ø3, ø4.5	1/8, 1/4	46	36	11	15
VXA22(3,4)0	VXA22(3,4)2	ø4.5, ø6	1/4, 3/8	56	46	13	17.5

(mm)



**Dimensions: Manifold/Body Material: Zn**

Normally closed (N.C.): VVXA21/VVXA22  
 Normally open (N.O.): VVXA21/VVXA22

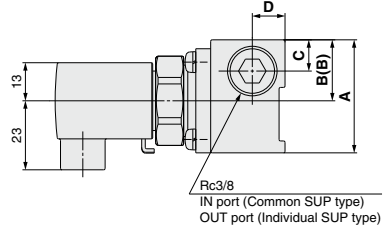
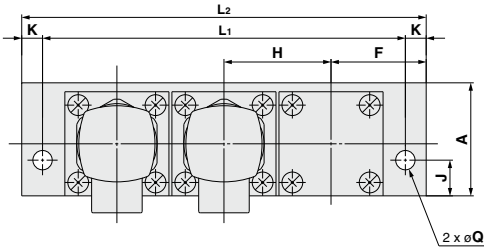

D side Stations ① ② ③ ... ① n U side

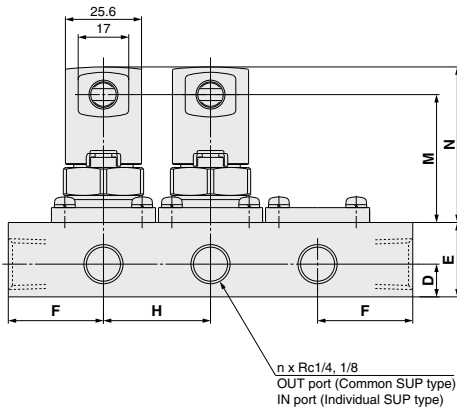

- VX2
- VXK
- VXD
- VXZ
- VXS
- VXE
- VXP
- VXR
- VXH
- VXF2
- VX3
- VXA

(mm)

Model	Dimension	n (Stations)									
		2	3	4	5	6	7	8	9	10	
VVXA21	L <sub>1</sub>	86	122	158	194	230	266	302	338	374	
	L <sub>2</sub>	100	136	172	208	244	280	316	352	388	
VVXA22	L <sub>1</sub>	108	154	200	246	292	338	384	430	476	
	L <sub>2</sub>	126	172	218	264	310	356	402	448	494	

(mm)

Model	A	B	(B) Individual SUP type	C	D	E	F	H	J	K	M	N	Q
VVXA21	38	20.5	17.5	10.5	11	25	32	36	12	7	43	52	6.5
VVXA22	49	26.5	22.5	13	13	30	40	46	15	9	48	57	8.5