



Floorcare & Specialty Motors

Model: 119440-00

DESCRIPTION

- One stage
- 230volts
- 5.1"/130 mm diameter
- Double ball bearings
- Single speed
- Thru-flow discharge
- Thermoset fan end bracket
- Thermoset bracket

DESIGN APPLICATION

- Equipment operating in environments not requiring separation of working air from motor ventilating air
- Designed to handle clean, dry, filtered air only

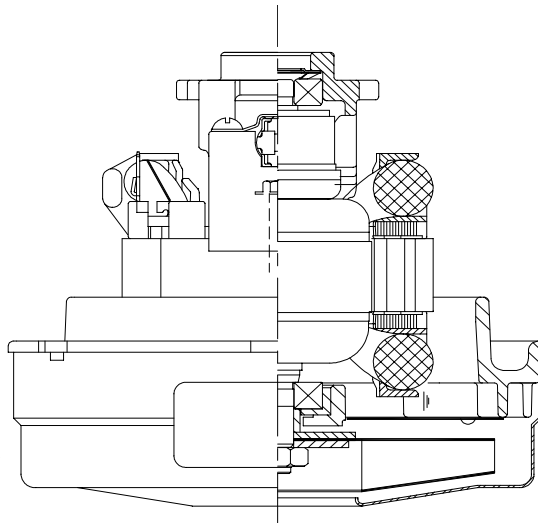

SPECIAL FEATURES

- Suitable for 230 volt AC operation, 50/ 60 Hz
- UL recognized, category PRGY2 (E47185)
- CSA certified, class 1611 01 (LR31393)
- Thermal Device
- Provision for grounding
- Thermoset frame design
- Tapered fan system
- High airflow fan system
- The Lamb Electric vacuum motor line offers a wide range of performance levels to meet design needs

TYPICAL MOTOR PERFORMANCE.*

(At 230 volts, 60Hz, test data is corrected to standard conditions of 29.92 Hg, 68° F.)

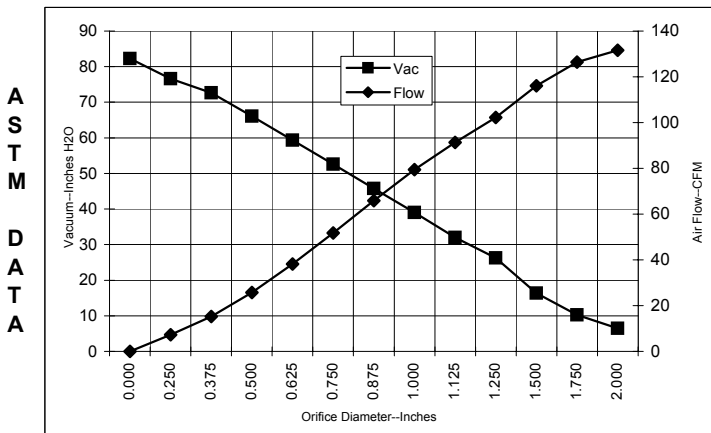

Orifice (Inches)	Amps	Watts (In)	RPM	Vac (In.H2O)	Flow (CFM)	Air Watts
2.000	4.7	1033	25720	6.4	131.7	100
1.750	4.7	1039	25565	10.2	126.4	152
1.500	4.7	1046	25500	16.3	116.0	223
1.250	4.7	1038	25675	26.3	102.2	316
1.125	4.6	1015	25890	32.0	91.4	344
1.000	4.5	989	26370	39.0	79.5	365
0.875	4.3	946	27100	45.8	65.9	355
0.750	4.0	892	28045	52.6	51.8	321
0.625	3.7	818	29200	59.3	38.1	266
0.500	3.3	741	30680	66.1	25.7	200
0.375	3.0	668	32180	72.7	15.3	131
0.250	2.7	609	33420	76.6	7.3	66
0.000	2.5	573	34340	82.3	0.0	0

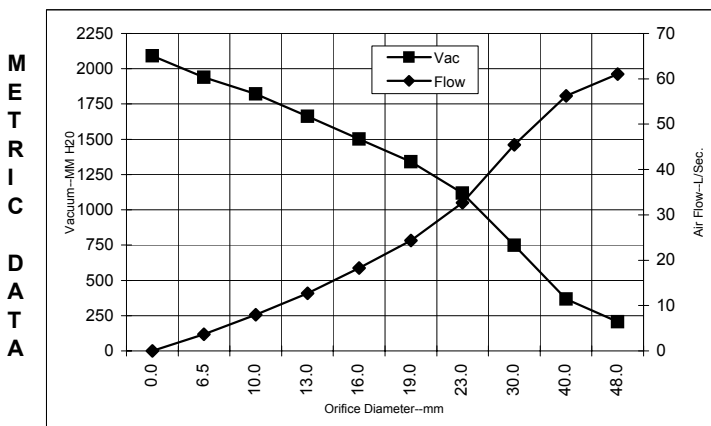

Orifice (mm)	Amps	Watts (In)	RPM	Vac (mm H2O)	Flow (L/Sec)	Air Watts
48.0	4.7	1035	25652	206	61.0	123
40.0	4.7	1044	25520	368	56.2	202
30.0	4.6	1025	25793	748	45.4	331
23.0	4.3	956	26918	1119	32.7	357
19.0	4.0	891	28068	1340	24.3	320
16.0	3.7	821	29154	1500	18.3	268
13.0	3.3	749	30532	1662	12.7	206
10.0	3.0	679	31955	1821	8.0	141
6.5	2.7	611	33358	1940	3.6	69
0.0	2.5	573	34340	2090	0.0	0

Note: Metric performance data is calculated from the ASTM data above.

* Data represents performance of a typical motor sampled from a large production quantity. Individual motor data may vary due to normal manufacturing variations.

Test Specs: 230 volts	Minimum Sealed Vacuum: 76"	ORIFICE: 7/8 "	Minimum Vacuum: 41"	Maximum Watts: 956
------------------------------	-----------------------------------	-----------------------	----------------------------	---------------------------

DIMENSIONS

NOTES:

1. MOTOR IDENTIFICATION: MANUFACTURER'S NAME, MODEL NUMBER, VOLTAGE, FREQUENCY, INSPECTORS CODE, DATE OF MANUFACTURE, AGENCY RECOGNITION CODE, PLANT LOCATION CODE AND MADE IN USA.
2. MOUNTING MUST NOT RESTRICT THIS DIAMETER.
3. GROUND LEAD: 18 GAUGE TINNED; COLOR TO BE GREEN W/YELLOW STRIPE

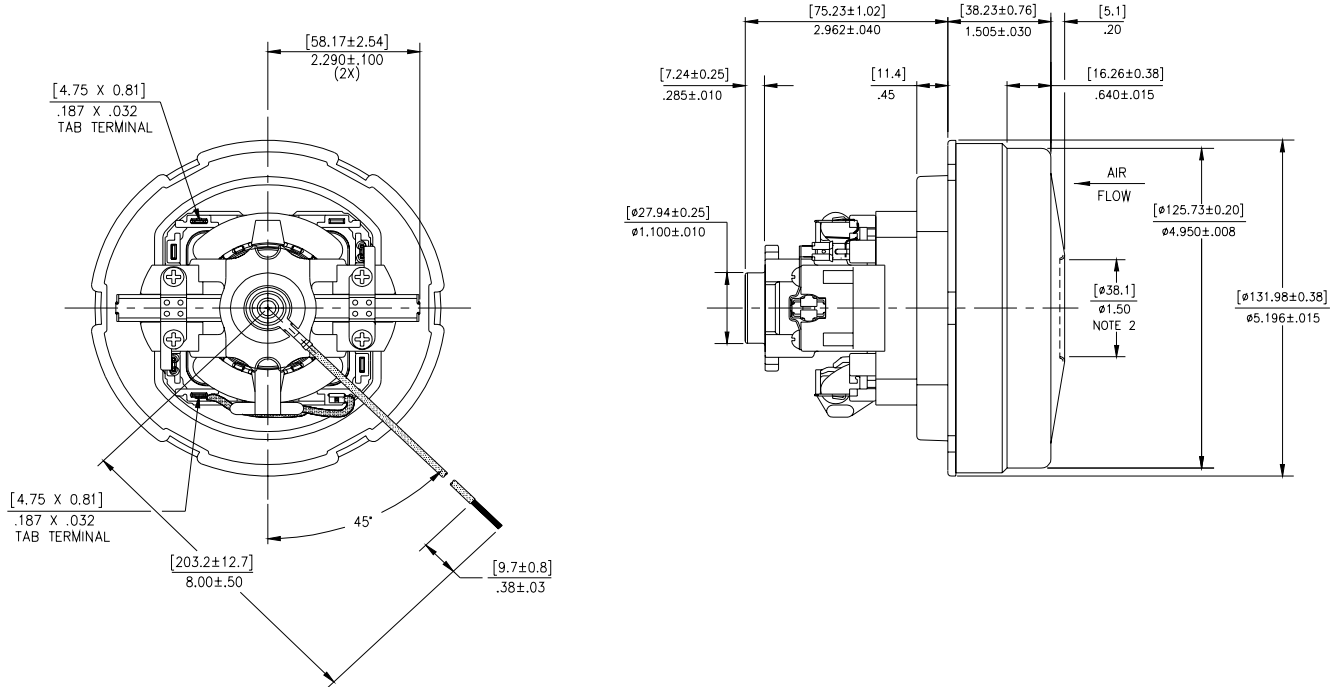

IMPORTANT NOTE: Pictorial and dimensional data are subject to change without notice. Contact factory for current revision levels.

WARNING - AMETEK Lamb Electric thru-flow vacuum motors must never be used in applications in which wet or moist conditions are involved, where dry chemicals or other volatile materials are present, or where airflow may be restricted or blocked. Such motors are designed to permit the vacuumed air to pass over the electrical winding to cool it. Thus any foam, liquid (including water), dry chemical, or other foreign substance coming in contact with electrical conductors could cause combustion (depending on volatility) or electrical shock. Failure to observe these precautions could result in property damage and severe personal injury, including death in extreme cases. All applications incorporating Lamb Electric motors should be submitted to Underwriters Laboratories Inc. or other appropriate organizations or agencies for testing specifically related to the safety of your equipment.

AMETEK/Floorcare & Specialty Motors
www.ametekfsm.com