

LAMB ELECTRIC

Model: 116549-00
116549-13*

DESCRIPTION

- Two stage
- 240 volts
- 5.7"/145 mm diameter
- Double ball bearing construction
- Single speed
- ACUSTEK® low-noise peripheral bypass discharge
- Thermoset fan end bracket
- Aluminum commutator bracket

DESIGN APPLICATION

- Equipment operating in environments requiring separation of working air from motor ventilating air
- Designed to handle clean, dry, filtered air only

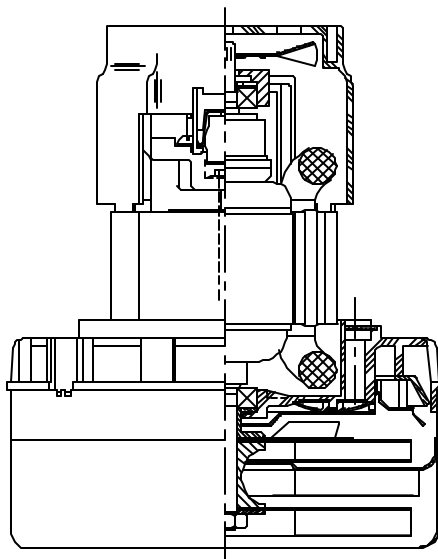

SPECIAL FEATURES

- Suitable for 240 volt operation, 50 or 60 Hz
- UL Recognized, category PGRY2 (E47185)
- Provision for grounding
- Skeleton-frame construction
- ACUSTEK® low-noise design, U.S. Patent #1,417,200
- The Lamb Electric vacuum motor line offers a wide range of performance levels to meet design needs

***Model 116549-13 features patented air seal bearing construction. U.S. Patent #4,088,424 and epoxy painted fan case**

TYPICAL MOTOR PERFORMANCE.*

(At 240 volts, 60Hz, test data is corrected to standard conditions of 29.92 Hg, 68° F.)

ASTM DATA

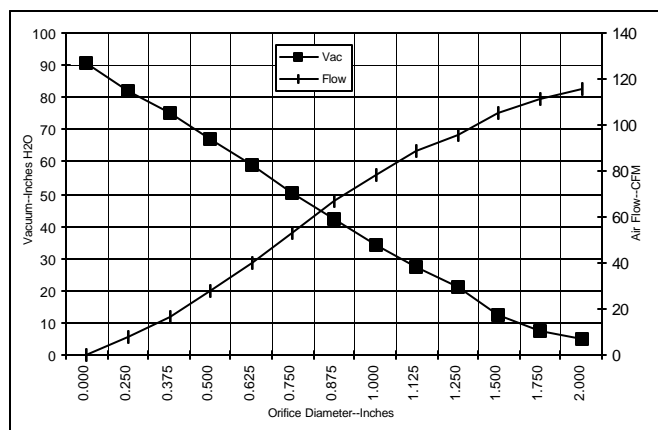

Orifice (Inches)	Amps	Watts (In)	RPM	Vac (In.H2O)	Flow (CFM)	Air Watts
2.000	5.9	1315	17741	4.7	116.0	64
1.750	5.9	1318	17714	7.5	111.6	98
1.500	5.8	1316	17730	12.3	105.2	151
1.250	5.8	1301	17850	21.1	95.9	238
1.125	5.7	1281	18044	27.3	88.3	283
1.000	5.5	1242	18413	34.3	78.2	315
0.875	5.3	1200	18813	42.5	66.6	332
0.750	5.1	1141	19357	50.5	53.4	316
0.625	4.7	1074	20041	58.8	40.0	276
0.500	4.3	985	21082	67.3	27.4	216
0.375	3.9	900	22109	75.3	16.3	114
0.250	3.6	818	23072	82.2	7.6	73
0.000	3.3	765	12855	90.6	0.0	0

METRIC DATA

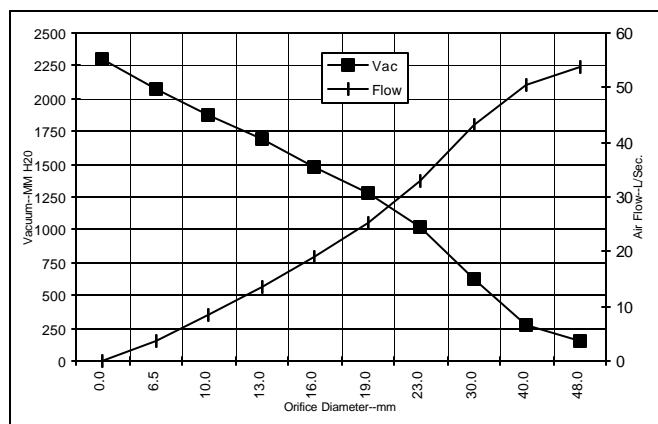

Orifice (mm)	Amps	Watts (In)	RPM	Vac (mm H2O)	Flow (L/Sec)	Air Watts
48.0	5.9	1316	17729	150	53.8	79
40.0	5.8	1317	17725	275	50.6	135
30.0	5.7	1290	17957	623	43.3	263
23.0	5.4	1211	18713	1027	32.8	328
19.0	5.1	1140	19371	1287	25.1	316
16.0	4.7	1077	20014	1486	19.1	278
13.0	4.4	994	20978	1688	13.5	222
10.0	4.0	913	21955	1882	8.5	129
6.5	3.6	822	23024	2079	3.8	75
0.0	3.3	765	12855	2301	0.0	0

Note: Metric performance data is calculated from the ASTM data above.

* Data represents performance of a typical motor sampled from a large production quantity. Individual motor data may vary due to normal manufacturing variati

Test Specs:	240 volts	Minimum Sealed Vacuum:	90.0"	ORIFICE:	13mm	Minimum Vacuum:	65.0"	Maximum Watts:	1200
-------------	-----------	------------------------	-------	----------	------	-----------------	-------	----------------	------

DIMENSIONS

NOTES

1. LEADS: 18GA STRANDED, LEADS CAN BE ANY COLOR EXCEPT GREEN OR GREEN WITH YELLOW STRIPE.
2. GROUNDING OR EARTHING PROVISIONS: USE HOLES AS INDICATED FOR GROUNDING OR EARTHING. REFER TO APPROPRIATE LISTING OR REGULATORY AGENCY FOR PROPER METHOD OF GROUNDING OR EARTHING.
3. RECOMMENDED SCREW SIZE 10-16 TYPE BT OR 25 THREAD CUTTING SCREW. MAXIMUM PENETRATION 17.40/.685

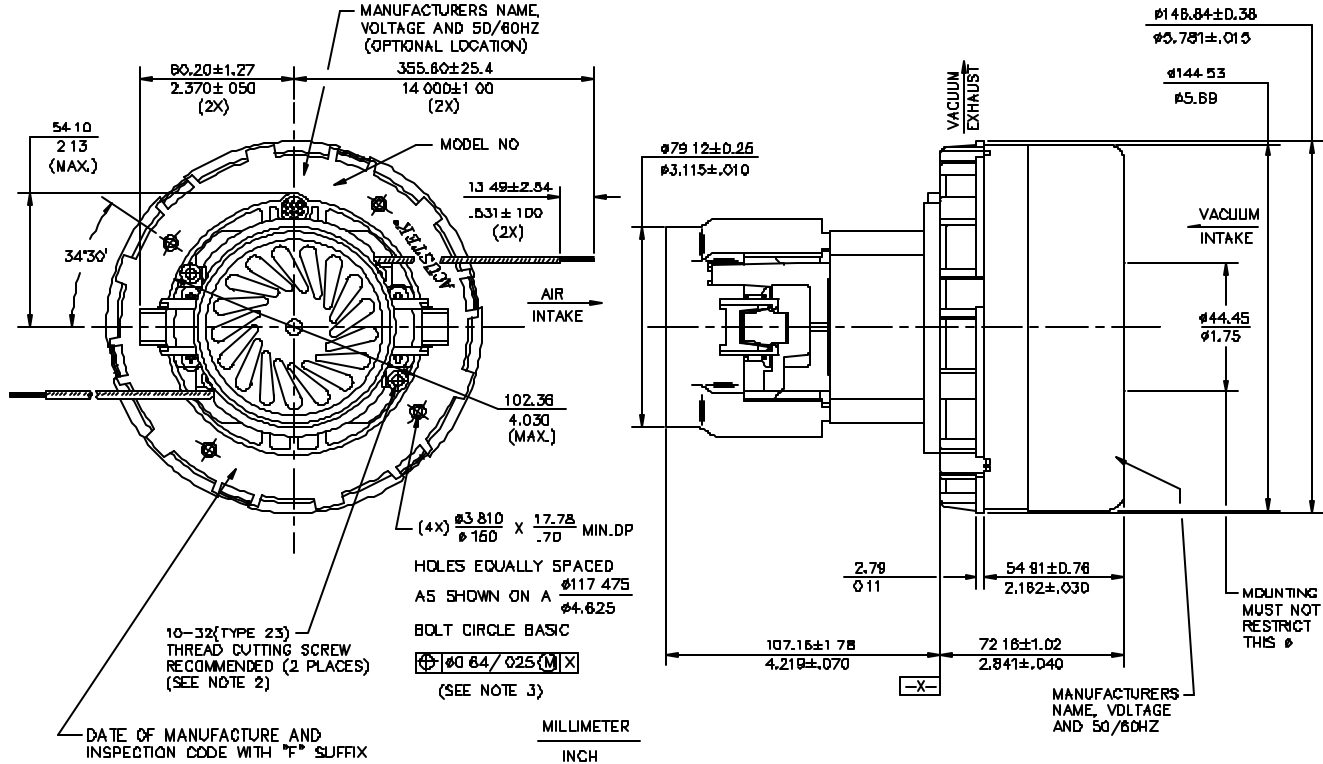

IMPORTANT NOTE: Pictorial and dimensional data are subject to change without notice. Contact factory for current revision levels.

WARNING - When using AMETEK Lamb Electric bypass motors in machines that come in contact with foam, liquid (including water), or other foreign substances, the machine must be designed and constructed to prevent those substances from reaching the fan system, motor housing, and electrical components. Lamb Electric vacuum motors other than hazardous duty models should not be applied in machines that come in contact with dry chemicals or other volatile materials. Failure to observe these precautions could cause flashing (depending on volatility) or electrical shock which could result in property damage and severe bodily injury, including death in extreme cases. All applications incorporating Lamb Electric motors should be submitted to appropriate organizations or agencies for testing specifically related to the safety of your equipment.

AMETEK/Lamb Electric Division
 627 Lake Street
 Kent, Ohio 44240
 U.S.A.
 Tel: (330) 673-3451
 Fax: (330) 673-8994

Ametek GmbH
 Weillimdorfer Str. 47
 D-70825 Korntal-Munchingen
 Germany
 Phone: + 49-711-838-7876
 Fax: + 49-711-838-7862

AMETEK/Singapore Private Limited
 10 Ang Mo Kio Street 65
 # 05-12 Techpoint
 Singapore 2056
 Tel: + 65-484-2388
 Fax: + 65-481-6588