

**69802-432LF - PLCC :**  
**Surface Mount Type Sockets**

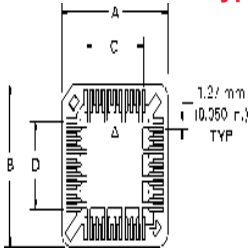

[www.fci.com](http://www.fci.com)

**Specifications**

<b>General</b>	
Location Peg	No
Number of contacts	32
Product Style	PLCC
<b>Electrical</b>	
Current rating	1 amp
Resistance (Contact)	20 m ohms max.
Resistance (Insulation)	1000 M ohms min.
Voltage rating	120V AC/DC
<b>Mechanical</b>	
Durability (Mating cycles)	25 Cycles
Insertion force	15 lbs max.
Withdrawal Force	1.5 lbs max.
<b>Mounting</b>	
Mounting style	Surface Mount
<b>Physical</b>	
Color (Housing)	Brown
Material (Contact)	Copper Alloy
Material (Housing)	PPS, UL94V-0
Plating (Inner clip / Contact)	150µ" Pure Tin
Underplating (Contact)	40µ" Nickel
Temperature (Range)	-55°C to 125°C
<b>Approvals / Certifications</b>	
Approvals / Certifications	UL Approved
<b>Other Features</b>	
Packaging (Type)	Tape and Reel



Copyright FCI.

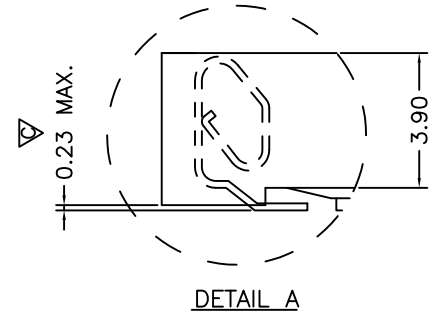
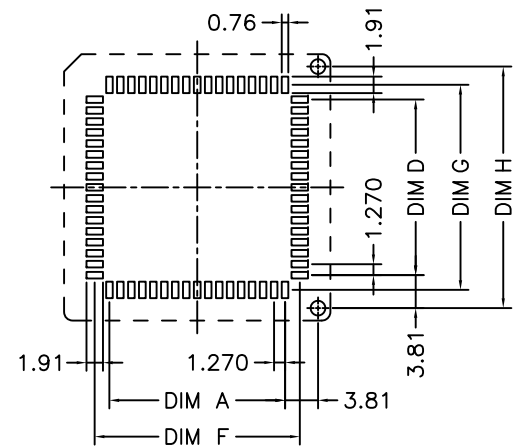
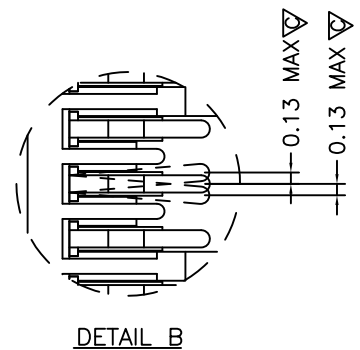
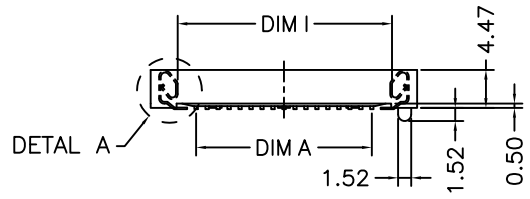
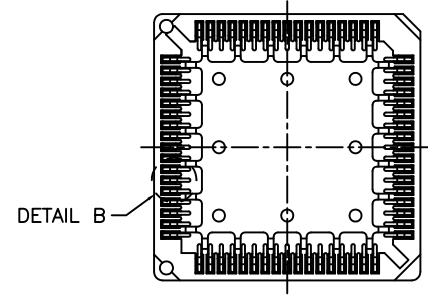
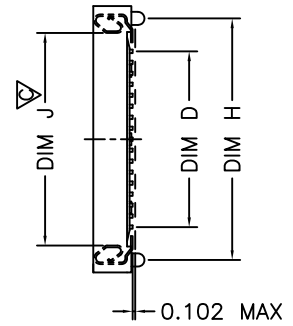
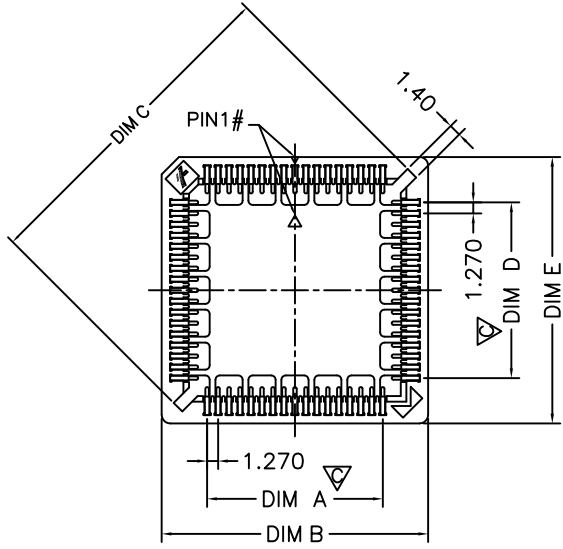

NOTE: DIMENSIONAL MARK  $\nabla$  TO BE CHECKED BY OQC.

rev	ecn no	dr	date
Y	T10136	JH	3/18/01
AA	T03-0452	JH	10/15/03
AB	T05-0017	JH	1/24/05
AC	T05-0114	JH	5/9/05
AD	T05-0212	JH	9/21/05
AE	T06-0070	JH	5/8/06
AF	T11-0002	JH	1/11/11

www.fciconnect.com			surface <input checked="" type="checkbox"/> tolerance std	projection <input checked="" type="checkbox"/>	MM
			TOLERANCES UNLESS OTHERWISE SPECIFIED		
Dr	Jason Hsu	1/11/11	ANGULAR	LINEAR	size A4
Eng	Jason Hsu	1/11/11	0.X	±0.25	Scale N/A
Chr	Gary Hsieh	1/11/11	0.XX	±0.15	
Appr	Joseph Hsia	1/11/11	0.XXX	±0.10	ECN T11-0002
			Product family		Spec ref
title PLCC SMT Socket			dng no 69802		Rev. AF
catalog no -			CUSTOMER		sheet 1 of 5

REV F - 2006-04-17

TABLE I

NO. OF CONTACTS	DIM. A ±0.20	DIM. B ±0.20	DIM. C ±0.20	DIM. D ±0.20	DIM. E MAX.	DIM. F ±0.10	DIM. G ±0.10	DIM. H ±0.20	DIM. I ±0.20	DIM. J ±0.20
20	5.08	15.24	16.70	5.08	15.24	8.48	8.48	12.70	9.40	
28	7.62	17.78	20.30	7.62	17.78	11.02	11.02	15.24	11.94	
32	7.62	17.78	22.50	10.16	20.32	11.02	13.56	17.78	11.94	14.48
44	12.70	22.86	27.50	12.70	22.86	16.10	16.10	20.32	17.02	
52	15.24	25.40	31.10	15.24	25.40	18.64	18.64	22.86	19.56	
68	20.32	30.82	38.30	20.32	30.82	23.72	23.72	27.94	24.64	
84	25.40	35.90	45.50	25.40	35.90	28.80	28.80	33.02	29.72	

TABLE II

PART NO.	WITH POLARIZING PEGS	PACKAGING BY PVC TUBE	PACKAGING BY TAPE & REEL	MCK PART NO.
69802-0XX	✓	✓		PLCC-XXP-T-SMT-P
69802-1XX		✓		PLCC-XXP-T-SMT
69802-4XX			✓	PLCC-XXP-T-SMT-TR
69802-0XXPT	✓	✓		PLCC-XXP-T-SMT-P-PT
69802-1XXPT		✓		PLCC-XXP-T-SMT-PT
69802-4XXPT			✓	PLCC-XXP-T-SMT-TR-PT
69802-0XXLF	✓	✓		PLCC-XXP-T-SMT-P-LF
69802-1XXLF		✓		PLCC-XXP-T-SMT-LF
69802-4XXLF			✓	PLCC-XXP-T-SMT-TR-LF

NOTE:

ORDERING DATA: 69802 - X XX XX

LF: LEAD FREE  
 PT: PURE TIN PLATED.  
 BLANK; TIN/LEAD PLATED.  
 NO OF CONTACTS  
 SEE TABLE II



Copyright FCI.

www.fciconnect.com			surface - <input checked="" type="checkbox"/>	tolerance std	projection	MM	
			TOLERANCES UNLESS OTHERWISE SPECIFIED				
Dr	Jason Hsu	1/11/11	ANGULAR	LINEAR	0.X ± 0.25	size A4	Scale N/A
Eng	Jason Hsu	1/11/11	0° ± 5°		0.XX ± 0.15	ECN	T11-0002
Chr	Gary Hsieh	1/11/11			0.XXX ± 0.10	Spec ref	
Appr	Joseph Hsia	1/11/11	Product family				
			title PLCC SMT Socket		dwg no 69802	Rev. AF	
			catalog no -		CUSTOMER	sheet 2 of 5	

A

A

NOTES:

1. MATERIAL:

1-1 HOUSING : PPS GB8411,UL94V-0 COLOR IN BROWN.  
 PLATING : 150u" TIN/LEAD OR PURE TIN MIN. OVER 40u" NICKEL MIN.  
 CONTACT : PHOSPHOR BRONZE C5212RH.

2. THE "FCI" LOGO IS LOCATED AS SHOWN.

3. RECOMMEND PCB LAYOUT IS SHOWN IN FIG.1.

4. COPLANARITY REQUIREMENT;

A. CONTACT MUST BE BELOW HOUSING BOTTOM SURFACE WITHIN 0.23MM.  
 B. CONTACT SEATING LINE MUST BE WITHIN 0.102MM.

5. THE POSITION OF PIN#1 IN THE CENTER PAD IS AS SHOWN.  
 20P, 28P NOT MOLDED ON THE EMBOSSED ARROW.

6. THE PACKAGING INFORMATION SHOWS ON SHEET 4 &5.

7. PRODUCT SPECIFICATION; GES-12-158.

8. MANUFACTURING PROCESS COMPATIBILITY: THE HOUSING WILL WITHSTAND EXPOSURE  
 TO 245°C PEAK TEMPERATURE FOR 5 SECOND IN A IR REFLOW APPLICATION.

B

B

C

C



Copyright FCI.

D

D

www.fciconnect.com			surface <input checked="" type="checkbox"/>		tolerance std		projection		MM		
			TOLERANCES UNLESS OTHERWISE SPECIFIED								
Dr	Jason Hsu	1/11/11	ANGULAR	LINEAR	0.X	± 0.25	size	A4	Scale		
Eng	Jason Hsu	1/11/11			0.XX	± 0.15			N/A		
Chr	Gary Hsieh	1/11/11	0°	±5°	0.XXX	± 0.10	ECN		T11-0002		
Appr	Joseph Hsia	1/11/11	Product family				Spec ref				
			title PLCC SMT Socket				dwg no 69802		Rev. AF		
			catalog no -				CUSTOMER		sheet 3 of 5		

A  
B  
C  
D

A  
B  
C  
D

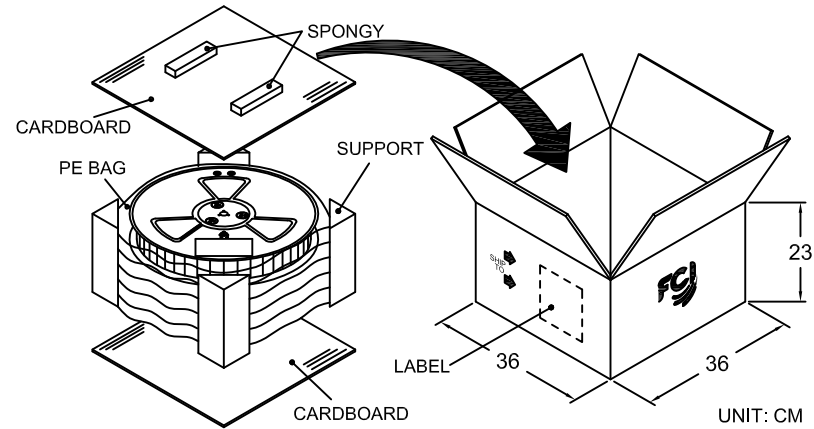
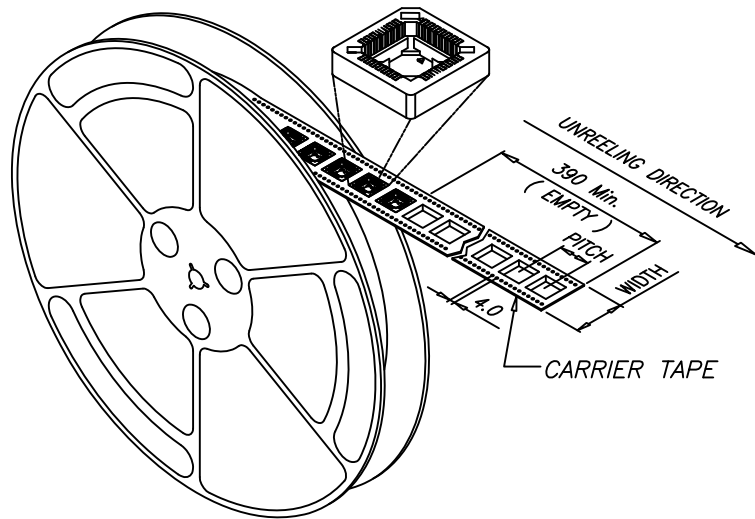

PACKING FOR 20P,28P,52P,680 & 84P

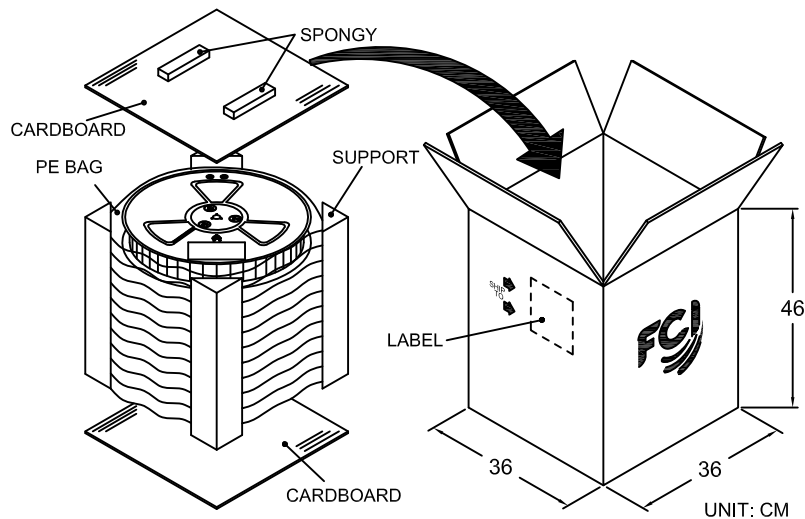

PACKING FOR 32P & 44P

TABLE III

NO. OF PIN.	WIDTH	PITCH	PCS/REEL	REEL/CARTON	TOTAL (PCS)
20P	24.0	24.00	470	6	2820
28P	32.0	24.00	390	5	1950
32P	32.0	24.00	390	10	3900
44P	44.0	32.00	250	8	2000
52P	44.0	32.00	250	4	1000
68P	44.0	36.00	220	4	880
84P	56.0	40.00	200	3	600

\*REEL DIAMETER:  $\varnothing$ 13 in"



Copyright FCI.

www.fciconnect.com		surface <input checked="" type="checkbox"/>	tolerance std	projection	MM
		TOLERANCES UNLESS OTHERWISE SPECIFIED			
Dr	Jason Hsu	1/11/11	ANGULAR	size	A4
Eng	Jason Hsu	1/11/11	LINEAR	0.X ±0.25	Scale N/A
Chr	Gary Hsieh	1/11/11	0° ±5°	0.XX ±0.15	
Appr	Joseph Hsia	1/11/11	Product family	0.XXX ±0.10	ECN T11-0002
title PLCC SMT Socket		dwg no 69802		Rev. AF	
catalog no -		CUSTOMER		sheet 4 of 5	

TABLE IV

A / P PART NO.	69802-X20X	69802-X28X	69802-X32X	69802-X44X	69802-X52X	69802-X68X	69802-X84X
DESCRIPTION	20P	28P	32P	44P	52P	68P	84P
PCS / TUBE	37	32	28	25	23	18	16
PCS / INNER BOX	1110	832	728	500	460	270	224
INNER BOX / CARTON ( WITH SOCKET )	3	4	10	10	4	5	5
INNER BOX / CARTON ( W / O SOCKET )	2	1	0	0	1	0	0
TOTAL (PCS)	3330	3328	7280	5000	1840	1350	1120
N.W.	3.2 KG	4.2 KG	10.0 KG	8.5 KG	3.2 KG	3.75 KG	3.5 KG
G.W.	6.5 KG	8.0 KG	18.0 KG	17.0 KG	7.0 KG	8.3 KG	8.0 KG

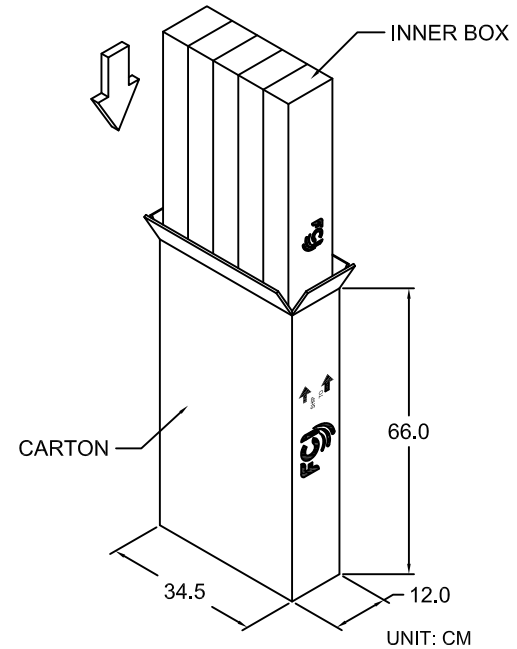

PACKING FOR 20P,28P,52P,680 & 84P

UNIT: CM

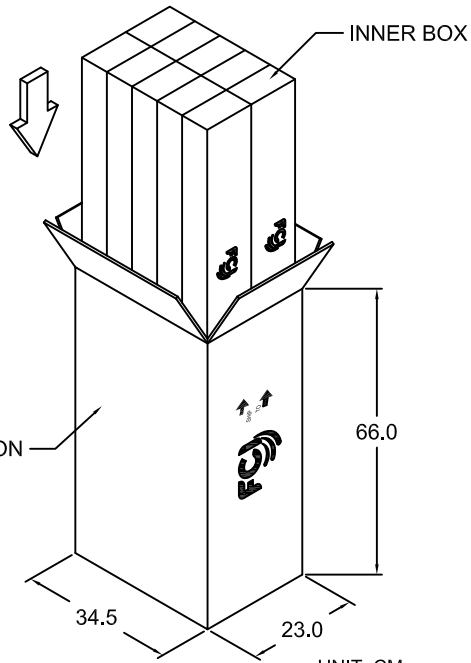

PACKING FOR 32P & 44P

UNIT: CM

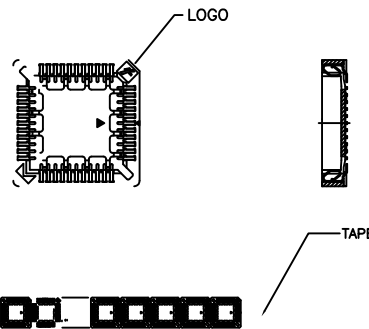

PACKAGING DIRECTION FOR PVC TUBE



Copyright FCI.

www.fciconnect.com			surface <input checked="" type="checkbox"/>	tolerance std	projection	MM	
			TOLERANCES UNLESS OTHERWISE SPECIFIED				
Dr	Jason Hsu	1/11/11	ANGULAR	0.X	± 0.25	size	Scale
Eng	Jason Hsu	1/11/11	LINEAR	0.XX	± 0.15	A4	N/A
Chr	Gary Hsieh	1/11/11	0° ± 5°	0.XXX	± 0.10	ECN	T11-0002
Appr	Joseph Hsia	1/11/11	Product family		Spec ref		
			title PLCC SMT Socket		dwg no	69802	Rev. AF
			catalog no		-	CUSTOMER	sheet 5 of 5