

PHASE BARRIERS INCREASED CREEPPAGES AND CLEARANCES

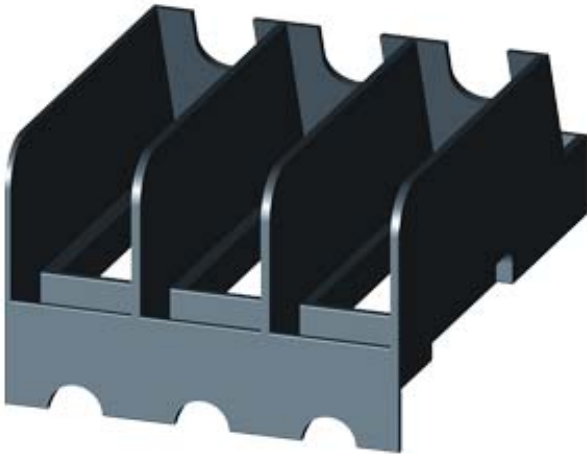

General technical data:

product brand name		SIRIUS
product designation		phase barrier
Design of the product		phase barrier for 3RV2
Ambient temperature		
• during operating	°C	-20 ... +70
• during storage	°C	-50 ... +80

Installation/mounting/dimensions:

Width	mm	44.8
Height	mm	29.3
Depth	mm	60.6

Certificates/approvals:

Verification of suitability		CE / UL / CSA / CCC
------------------------------------	--	---------------------

General Product Approval	Declaration of Conformity	Test Certificates	
--------------------------	---------------------------	-------------------	--



[Special Test Certificate](#)

[Type Test Certificates/Test Report](#)

Shipping Approval



Shipping Approval

other



[other](#)

Further information:

Information- and Downloadcenter (Catalogs, Brochures,...)

<http://www.siemens.com/industrial-controls/catalogs>

Industry Mall (Online ordering system)

<http://www.siemens.com/industrial-controls/mall>

CAX-Online-Generator

<http://www.siemens.com/cax>

Service&Support (Manuals, Certificates, Characteristics, FAQs,...)

<http://support.automation.siemens.com/WW/view/en/3RV2928-1K/all>

Image database (product images, 2D dimension drawings, 3D models, device circuit diagrams, ...)

http://www.automation.siemens.com/bilddb/cax_en.aspx?mlfb=3RV2928-1K

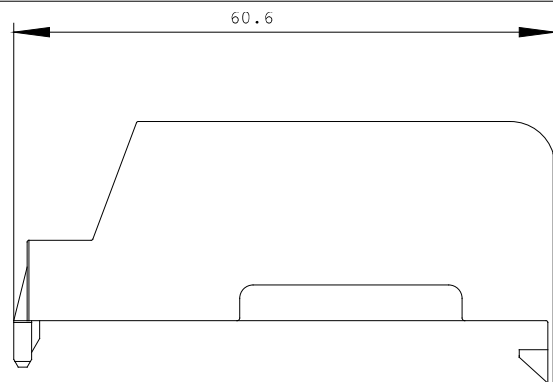
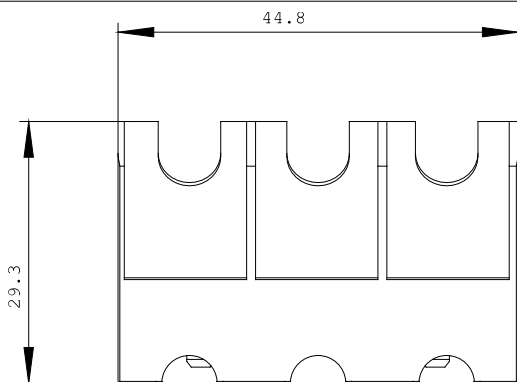

last change:

Jun 5, 2012