

**DILB16P-223TLF - DIP : DIP
Socket, Stamped and Formed**

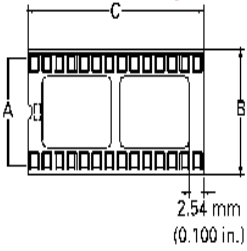

www.fci.com

Specifications

General	
Contact type	SAF
Number of contacts	16
Number of contacts (per row)	8
Number of rows	2
Product Style	DIP, Stamped and Formed
Frame Type Style	Open
Gender (Contact)	Socket
Insulator Type	Standard
Dimensional	
Length (Tail)	3.2 mm (0.126 in.)
Dim D (in)	0.3 in.
Dim D (mm)	7.62 mm
Spacing (Contact)	2.54 mm (0.1 in.) Pitch
Dim A (in)	0.8 in.
Dim A (mm)	20.32 mm
Dim B (in)	0.7 in.
Dim B (mm)	17.78 mm
Dim C (in)	0.4 in.
Dim C (mm)	10.16 mm
Spacing (Row to row)	7.62 mm (0.3 in.)
Electrical	
Withstanding Voltage	1000V AC RMS min.
Current rating	1 amps max.
Resistance (Contact)	30 M ohms max. at 6V DC
Resistance (Insulation)	1000 M ohms min. at 500V DC
Voltage rating	200V AC
Mechanical	
Durability (Mating cycles)	25 Cycles
Insertion force	340.2g/Contact max.
Withdrawal Force	14.5g/Contact min.
Mounting	

Mounting style	Through Hole
Physical	
Color (Housing)	Black
Material (Contact)	Copper Alloy
Plating (Inner clip / Contact)	100μ" min. Pure Tin over 50μ" Nickel
Material (Inner clip / Contact)	Copper Alloy
Material (Insulator)	Polyester, UL 94V-0
Temperature (use - continuous)	-55°C to 105°C
Approvals / Certifications	
Approvals / Certifications	UL/CSA Pending
Other Features	
Packaging (Type)	Tube



CATALOG NO	NO.OF CONTACTS	TABLE OF DIMENSIONS		
		A±0.30	BE0.25	CE0.30I D±0.20
DILB8P-2231XX	8P	10.16	7.62	
DILB14P-2231XX	14P	17.78	15.24	
DILB16P-2231XX	16P	20.32	17.78	10.16
DILB18P-2231XX	18P	22.86	20.32	7.62
DILB20P-2231XX	20P	25.40	22.86	
DILB24P-2241XX	24P	30.48	27.94	
DILB24P-2231XX	24P	30.48	27.94	
DILB28P-2231XX	28P	35.56	33.02	
DILB32P-2231XX	32P	40.64	38.10	17.78
DILB40P-2231XX	40P	50.80	48.26	
DILB42P-2231XX	42P	53.34	50.80	15.24

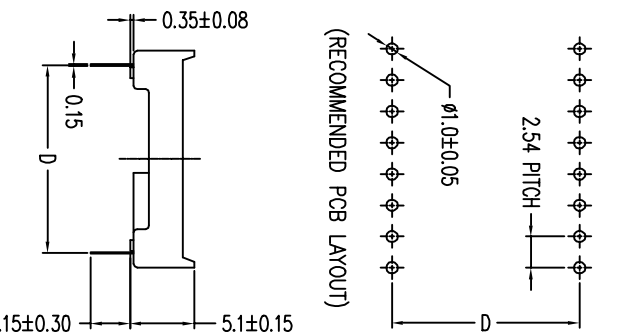
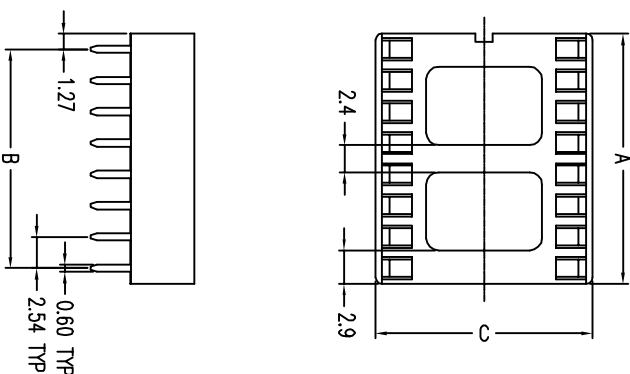

NOTES

- MATERIALS
HOUSING: POLYAMIDE, UL94V-0 COLOR IN BLACK.
CONTACT: COPPER ALLOY.
- FINISH
100µ" MIN. MATTE OR BRIGHT TIN OVER 50µ" MIN. NICKEL.
- PERFORMANCE CHARACTERISTICS
 - OPERATING VOLTAGE: 200VAC;
 - CONTACT RESISTANCE: 30 MILLIOHMS MAX. AT 6 VDC;
 - CURRENT RATING: 1 AMP. MAX.;
 - OPERING TEMPERATURE: CONTINUOUS, -55C TO 105C;
 - INSULATION RESISTANCE: 1000 MEGOHMS MIN AT 500 VDC;
 - DIELECTRIC WITHSTANDING VOLTAGE: 1000 VAC RMS MIN.;
 - DURABILITY: NO ELECTRICAL DEGRADATION AFTER 25 CYCLES;
 - THERMAL SHOCK: NO PHYSICAL OR ELECTRICAL DEGRADATION PER MIL-STD-1344, METHOD 1003, COND A;
 - MOISTURE RESISTANCE: 300 MEGOHMS MIN PER MIL-STD-202, METHOD 106, OMIT STEPS 7a AND 7b;
 - VIBRATION: NO ELECTRICAL INTERRUPTION GREATER THAN 1 MICROSECOND PER MIL-STD-1344, METHOD 2005 COND III;
 - MECHANICAL SHOCK: NO ELECTRICAL INTERRUPTION GREATER THAN 1 MICROSECOND WHEN 17.64 oz (500g) IS APPLIED FOR 0.75 MILLISECOND;
 - FLAMABILITY: UL94 V-0;
 - INSERTION FORCE 340.2g /CONTACT MAX.; WITHDRAWAL FORCE: 14.5g/CONTACT MIN.;
- DILBXXP-2231XX: THE HOUSING WILL WITHSTAND EXPOSURE TO 260° PER PERK TEMPERATURE FOR 10 SECONDS IN A WAVE SOLDER APPLICATION.

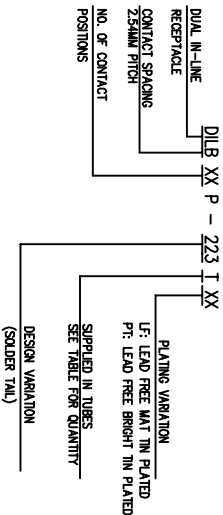

mat'l. code	itr	ecn no.	dr	date	tolerances unless otherwise specified	CUSTOMER COPY	FCI	product family	EDGE CARD	code
A	106-0016	W.L	1/24/05		.XX ± 0.2	projection		DILB ASSEMBLY		TWN
B	106-0053	J.H	3/28/06		.XXX ± 0.05					10052485
C	106-0068	J.H	7/7/06		0° ± 2°					1 of 2
sheet	revision	C	C	C	dr	WADE LUV	01/05/05	product family	EDGE CARD	code
index	sheet	1	2		engr	WADE LUV	01/05/05	size	dwg no	sheet
					appr	STERLING LIN	01/08/05	scale		1 of 2
								1:1		

ACAD

cgge code
22526

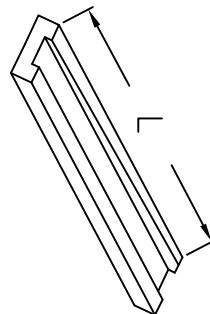

L	635	635
W	136	136
H	116	116

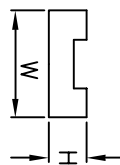

Tube

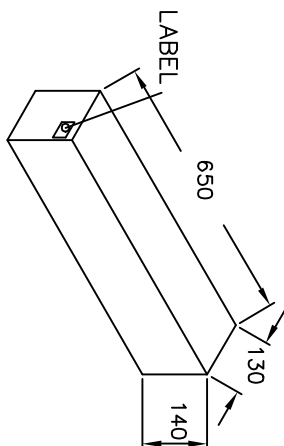

Box

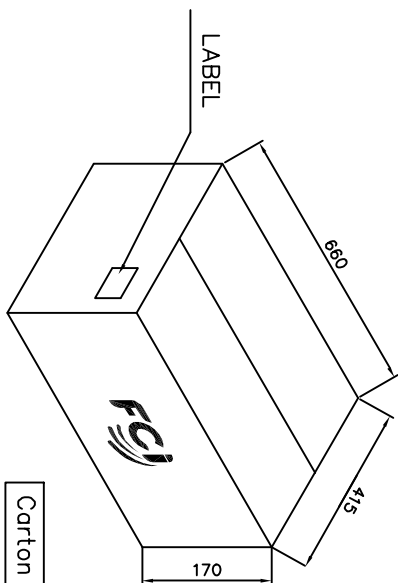

Carton

DILB PACKING LIST FOR TUBE

	CONTACTS	Pcs/TUBE	TUBE /INNER BOX	PCS / INNER BOX	INNER BOX	OUTER BOX	PCS / OUTER BOX
DILB8P-223TX	8P	60	100	6000	3	3	18000
DILB14P-223TX	14P	34	100	3400	3	3	10200
DILB16P-223TX	16P	30	100	3000	3	3	9000
DILB18P-223TX	18P	26	100	2600	3	3	7800
DILB20P-223TX	20P	24	100	2400	3	3	7200
DILB24P-224TX	24P	20	100	2000	3	3	6000
DILB24P-223TX	24P	20	60	1200	3	3	3600
DILB28P-223TX	28P	17	60	1020	3	3	3060
DILB32P-223TX	32P	15	60	900	3	3	2700
DILB40P-223TX	40P	12	60	720	3	3	2160
DILB42P-223TX	42P	11	60	660	3	3	1980

mat'l code		tolerances unless otherwise specified		CUSTOMER COPY		FCI		title		product family		EDGE CARD		code	
itr	ecn no	dr	date	linear	.XX ± 0.3	projection				MM	product family	EDGE CARD	code	TWIN	
C				.XXX ± 0.05	0' ± 2"				1:1	scale	10052485		sheet	2 of 2	
				angles									sheet	2 of 2	
sheet	revision	C	C	dr	WADE LIU	01/05/05									
index	sheet	1	2	chr	WADE LIU	01/05/05									
				appd	STERLING LIN	01/08/05									

ACAD

code code
22526