

MODEL 25

True RMS 3-Phase Monitor



- User selectable relay operation options
- Low or High Trip with independent delays or disabled
- User programmable
- Can be restored to factory settings or calibrated in the field using a True RMS Voltmeter
- Model 25SG has silver with gold flash contacts for low current.



DESCRIPTION

Model 25 True RMS 3-Phase Monitor has a display that shows the voltage with an accuracy of +/- 0.5%. The display is updated every second and re-initialized every 30 seconds.

This unit has a user selectable relay option for High-Low or DPDT. It can also be user-selected to energize on fault or de-energize on fault. The user can select automatic or manual restart on the Model 25. The SG version of the Model 25 has silver with gold flash contacts for low current applications.

Model 25 True RMS 3-Phase Monitor can be either calibrated using a True RMS Voltmeter or can be restored to factory defaults in the field.

UL SPECIFICATIONS*

Model	25 and 25SG
Input	
Voltage (VAC)	80-550 Volts
Amps	1mA
Frequency	50/60Hz (400Hz optional with jumper)
DC Power	24 Volts, 2 watts
Output	240V AC, 10A, Resistive 120V AC, 4A, General Use 240V AC, 2A, General Use C300, Pilot Duty

OTHER SPECIFICATIONS

Model	25 and 25SG
Start-up Delay	5 secs. Min. or Automatic reset delay setting (to allow for solid lock)
Repeat Accuracy	± 0.5 % (fixed conditions)
Reset Type	Manual or Automatic
Expected Relay Life	Mech: 10 million operations Elec: 100,000 min. at rated load
Operating Temp	-20°F to +130°F
Humidity Tolerance	0-97% w/o condensation
Enclosure Material	Lexan 920 Polycarbonate UL 94 V-0 1.5 mm UL E45329
Mounting	DIN Rail 35mm
Weight	8.5 oz.

* R/C or Listed (Type 1 or Type 2) UL 1449 overvoltage control devices with a Voltage Protection Rating of 6KV max.

* For use in a Pollution Degree 2 Environment.

Telephone: Main - (918) 438-1220

Sales - (800) 862-2875

Fax: (918) 437-7584

E-mail: sales@time-mark.com

Internet: http://www.time-mark.com



TIME MARK
CORPORATION

11440 East Pine Street
Tulsa, Oklahoma 74116

Page 1 of 4 06/2013

© 2013 TIME MARK CORPORATION

TIME MARK is a division of AEMT, Inc.

MODEL 25

True RMS 3-Phase Monitor

READ ALL INSTRUCTIONS BEFORE INSTALLING, OPERATING OR SERVICING THIS DEVICE.
KEEP THIS DATA SHEET FOR FUTURE REFERENCE.

GENERAL SAFETY

POTENTIALLY HAZARDOUS VOLTAGES ARE PRESENT AT THE TERMINALS OF THE MODEL 25.
ALL ELECTRICAL POWER SHOULD BE REMOVED WHEN CONNECTING OR DISCONNECTING WIRING.
THIS DEVICE SHOULD BE INSTALLED AND SERVICED BY QUALIFIED PERSONNEL.

Installation Instructions

INSTALLATION AND SETUP

Controls:

Rotary encoder with switch. Pressing the encoder switch will display the set points. Pressing the encoder switch for more than 5 seconds will enter the setup mode. Pressing switch displays the next menu item. Holding down the switch during setup mode will sequence through menus with 1 second intervals. Rotating the knob clockwise increases the value and counter-clockwise will decrease value.

For non-value options, rotating the knob either way will change the options on the display.

Setup Options:

(Press encoder for at least 5 seconds to enter setup)

High Voltage: (Factory—Enabled, Set point = 550V, Delay = 5S)

Enable/Disable:

(*If disabled set point and delay are skipped)

Set Point Range:

Low setpoint + 1% to 550V in 0.5V steps

High Trip Delay:

0 to 20.0 seconds in 0.1Sec steps

Low Voltage: (Factory—Enabled, Set point = 80V, Delay = 5S)

Enable/Disable:

(*If disabled set point and delay are skipped)

Set Point Range:

80 to High Setpoint -1% in 0.5V steps

Low Trip Delay:

0 to 20.0 seconds in 0.1Sec steps

TYPICAL APPLICATION—MONITOR AND CONTROL

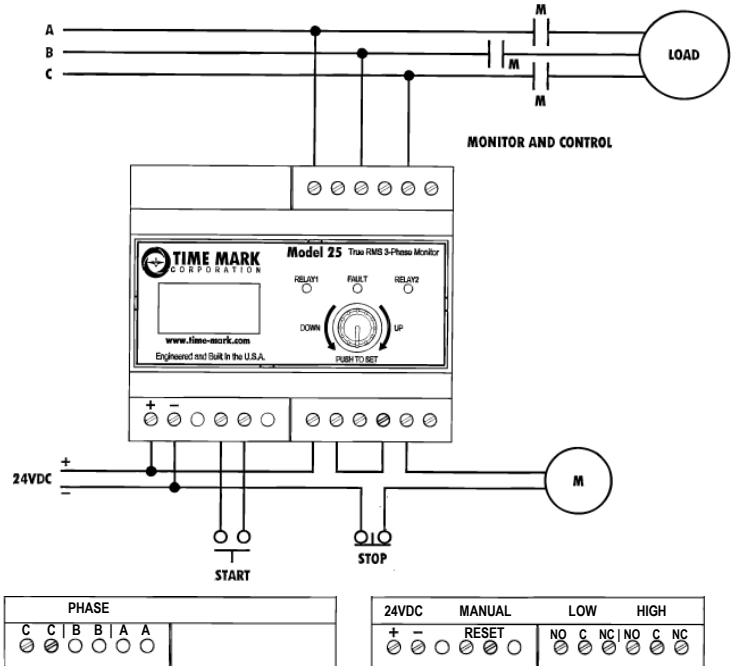

TYPICAL APPLICATION—MONITOR AND ALARMS

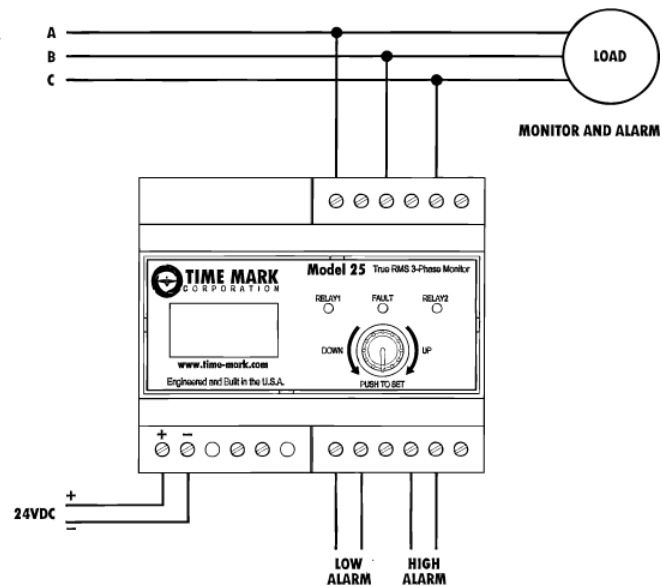

Telephone: Main - (918) 438-1220

Sales - (800) 862-2875

Fax: (918) 437-7584

E-mail: sales@time-mark.com

Internet: http://www.time-mark.com



TIME MARK
CORPORATION

11440 East Pine Street
Tulsa, Oklahoma 74116

Page 2 of 4 06/2013

© 2013 TIME MARK CORPORATION

TIME MARK is a division of AEMT, Inc.

READ ALL INSTRUCTIONS BEFORE INSTALLING, OPERATING OR SERVICING THIS DEVICE.
KEEP THIS DATA SHEET FOR FUTURE REFERENCE.

GENERAL SAFETY

POTENTIALLY HAZARDOUS VOLTAGES ARE PRESENT AT THE TERMINALS OF THE MODEL 25.
ALL ELECTRICAL POWER SHOULD BE REMOVED WHEN CONNECTING OR DISCONNECTING WIRING.
THIS DEVICE SHOULD BE INSTALLED AND SERVICED BY QUALIFIED PERSONNEL.

Installation Instructions

INSTALLATION AND SETUP (Continued)

Relay Operation: (Factory = HI-LO)

Voltage High/Low Option:
Separate High/Low Relays
DPDT

Other faults DPDT

Relay Operation on Fault: (Factory - De-energize on fault)

De-energize on fault
Energize on fault
Hysteresis set
Unbalance set
Phase Loss set
Reverse Phase set

Restart: (Factory - Automatic)

Automatic or Manual (in Manual rotating the knob or closing an external switch will reset the unit)

Automatic Restart Delay Range: (Factory - 5S)

0 to 300.0 Seconds in 0.1 Second steps

Exit from Setup Options:

Repeat Setup:
Press encoder to begin setup from beginning.
(High Enable)

Exit & No Save:
Press encoder to exit setup. Any changes have been discarded.

Exit & Save:
Press encoder to exit setup and save changes.
Unit will begin using new settings.

Start Up Delay:

5 Seconds Minimum or Automatic Restart Delay setting (to allow for solid lock).

OPTIONAL 400HZ FREQUENCY SETUP

To change the Model 25 from the factory default 50/60Hz frequency to 400Hz, simply remove the blank cover plate (without holes) and move the jumper from 50/60Hz to 400Hz. Replace the cover plate when completed.

UNIT FIELD RESTORE SETTINGS AND RECALIBRATION

- 1) From a powered down condition, apply the 3-Phase voltage first.
- 2) Press and hold the Encoder switch while applying the DC power to the unit. As soon as the splash screen appears, release the button. After the splash screen ends, the display will show "No Rest Fac". Rotate encoder to change option to "Yes" to restore factory settings. Press the Encoder switch.
- 3) The display will show the phase A-B voltage. Place a meter between phases A and B. Rotate encoder to change the reading on the display to be what is on the meter. When readings match (+/-0.5V), press the Encoder switch.
- 4) The display will show the phase B-C voltage. Place a meter between phases B and C. Rotate encoder to change the reading on the display to be what is on the meter. When readings match (+/-0.5V), press the Encoder switch.
- 5) The display will show the phase C-A voltage. Place a meter between phases C and A. Rotate encoder to change the reading on the display to be what is on the meter. When readings match (+/-0.5V), press the Encoder switch.
- 6) The unit will return to normal operation.

Telephone: Main - (918) 438-1220

Sales - (800) 862-2875

Fax: (918) 437-7584

E-mail: sales@time-mark.com

Internet: http://www.time-mark.com



TIME MARK
CORPORATION

11440 East Pine Street
Tulsa, Oklahoma 74116

Page 3 of 4 06/2013
© 2013 TIME MARK CORPORATION

TIME MARK is a division of  AEMT, Inc.

MODEL 25

True RMS 3-Phase Monitor

READ ALL INSTRUCTIONS BEFORE INSTALLING, OPERATING OR SERVICING THIS DEVICE.
KEEP THIS DATA SHEET FOR FUTURE REFERENCE.

GENERAL SAFETY

POTENTIALLY HAZARDOUS VOLTAGES ARE PRESENT AT THE TERMINALS OF THE MODEL 25.
ALL ELECTRICAL POWER SHOULD BE REMOVED WHEN CONNECTING OR DISCONNECTING WIRING.
THIS DEVICE SHOULD BE INSTALLED AND SERVICED BY QUALIFIED PERSONNEL.

Installation Instructions

DIMENSIONS

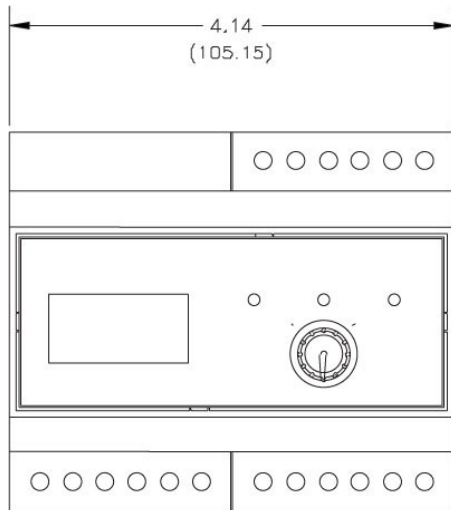
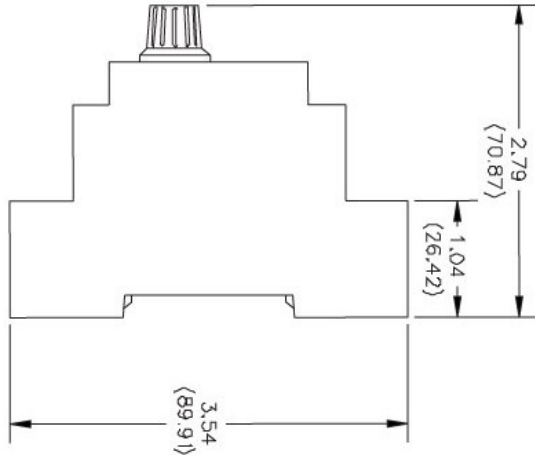

WARRANTY

This product is warranted to be free from defects in materials and workmanship, and is covered by our exclusive **5-year Unconditional Warranty**. Should this device fail to operate for any reason, we will repair it for five years from the date of manufacture. For complete warranty details, see the *Terms and Conditions of Sales* page in the front section of the Time Mark catalog or contact Time Mark at 1-800-862-2875.

Telephone: Main - (918) 438-1220
Sales - (800) 862-2875
Fax: (918) 437-7584

E-mail: sales@time-mark.com
Internet: http://www.time-mark.com



TIME MARK
CORPORATION

11440 East Pine Street
Tulsa, Oklahoma 74116

Page 4 of 4 06/2013
© 2013 TIME MARK CORPORATION

TIME MARK is a division of  AEMT, Inc.