

OPERATION

FOUR CONTROL SWITCHING: Do not remove factory-installed jumper between terminals 2 and 3. The control switches connected to terminals 3 through 6 are labeled OFF (cs2), LEAD (cs3), LAG (cs4) and ALARM (cs5). Under normal operation the lead load energizes when the off and lead control switches close in order. The lag load energizes when the lag closes and the alarm load energizes when the alarm switch closes. When all four switches reopen in the proper order all outputs are de-energized and the lead/lag output designations reverse.

FIVE CONTROL SWITCHING: Remove factory installed jumper between terminals 2 and 3. After the jumper has been removed, the additional control switch is connected to terminal 2. The extra switch functions as an AUXILIARY OFF (cs1) switch. It is used to prevent loads from running continuously if the primary OFF (cs2) switch fails to open properly.

FAULT DETECTION ALGORITHM: If any of the control switches open or close out of order, the alarm output energizes and a fault detection algorithm is used to identify the faulty switch. The faulty switch is then ignored and the OFF, LEAD, and LAG control switch designations are altered to maintain safe operation.

DIMENSIONS (INCHES)

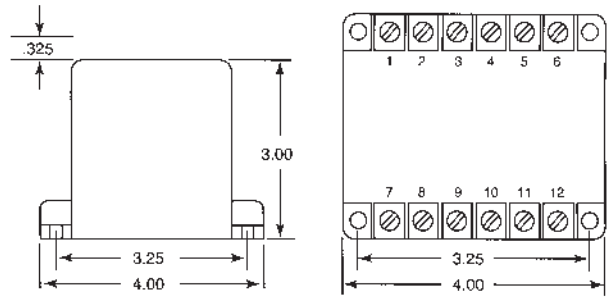

*Panel Mount Cutout

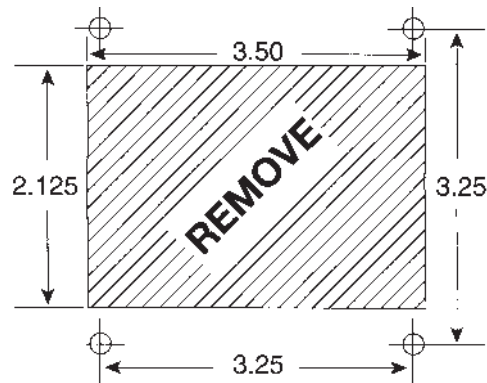

*greenlee punch #60071 or equivalent

WIRING

CONTROL DRAWING 190

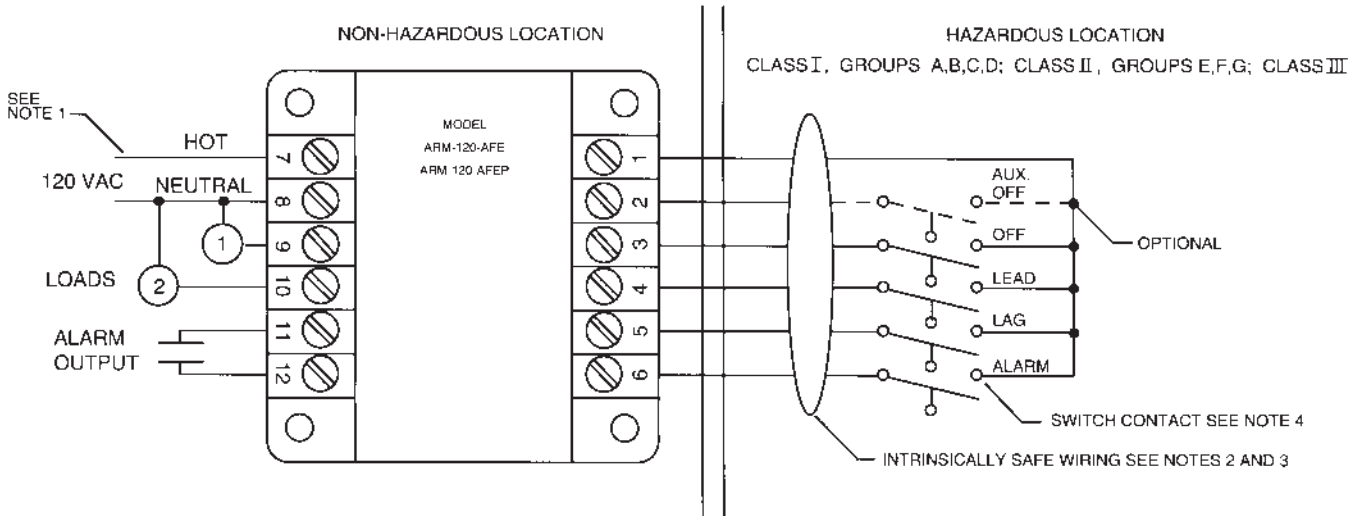

1. To maintain intrinsic safety, connect the Controller's Earth Ground Terminal 8 to the earth ground of the AC Power Supply feeder. The resistance between the Controller's Earth Ground Terminal and Earth Ground shall be less than 1 ohm.
2. Maximum distance between Controller and switch contact is 1000 feet.

3. All intrinsically safe wiring shall be separated from non-intrinsically safe wiring. Refer to article 504 of the National Electrical Code ANSI/NFPA 70 on procedures for intrinsically safe wiring.
4. Switch contact shall be any non-energy storing or generating mechanical switch type device containing no capacitance or inductance.

These **Triplex** and **Quadraplex** Controllers are available with *either* Sequence-On-Simultaneous-Off (SOSO) or First-On-First-Off (FOFO) output logic. The special function models are differentiated by a rotary switch that allows any output to be locked as the lead load or any one load to be omitted while sequencing only the remaining loads. In addition to load omission and lead selection, the expandable model can be set for 2, 3, or 4 load operation with either SOSO or FOFO logic.

All models feature **intrinsically safe inputs** and logic that allows the outputs to operate properly even if one of the inputs fails to open or close. For example: if the off switch fails to close, the lead load will not energize until both the lead and the lag switches close. An inrush delay on all models reduces line sags by preventing multiple loads from energizing simultaneously.

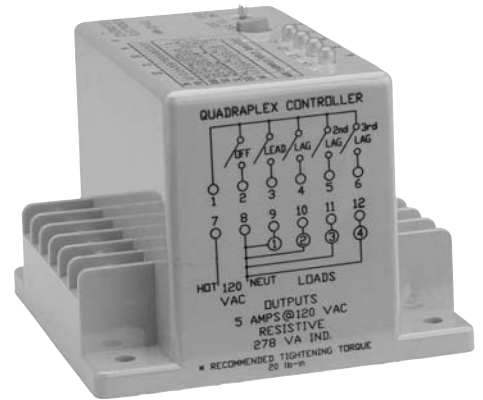

7M26
UL913

Alternating Controllers

DIMENSIONS (INCHES)

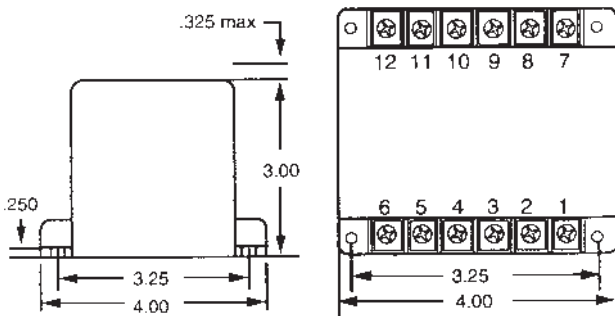

- 3 and 4 Load Output Models
- Intrinsically Safe Inputs
- 2-4 Load Expandable Model

MODEL NUMBER >>>>>>	ARM	E
Control Voltage		
24 VAC	24	
120 VAC	120	
Number of Loads	Output Logic	Special Functions
3	SOSO	none
3	FOFO	none
3	SOSO	Omit/Lead Select
3	FOFO	Omit/Lead Select
4	SOSO	none
4	FOFO	none
Enclosure		
E		
Mount		
No Suffix Surface Mount		
P Suffix Panel Mount		
		P

SPECIFICATIONS

CONTROL VOLTAGE	24 or 120 VAC ±10%, 50/60 Hz	
SWITCH VOLTAGE	5.1 Volts open circuit	
SWITCH CURRENT	10 µAmps short circuit	
POWER REQUIRED	2.5 VA	
SENSITIVITY	100 k ohm	
ISOLATION	2500V Input to Output	
DUTY CYCLE	Continuous	
RESPONSE TIMES	Power Up	< 1 SEC
	Operate	< 25 mSEC (switch closure)
	Inrush	5 SEC
	Release	< 150 mSEC
CONTACT RATING	All channels, SPST-N.O., 5 Amps per channel @ 24 or 120 VAC, Resistive; 278 VA, Inductive	
LED INDICATORS	ON when corresponding output is ON	
LIFE EXPECTANCY	Mechanical	20 Million Operations
	Electrical	50,000 Operations
TEMPERATURE RATING	Operate	-4° to 131°F (-20° to +55°C)
	Storage	-40° to 185°F (-40° to +85°C)
TERMINATIONS	(12) #8-32 Screw terminals with pressure clamps	
ENCLOSURE	Style "E" Surface mount	
WEIGHT	16 oz.	

OPERATION—TRIPLEX CONTROLLERS

Intrinsically safe equipment and wiring is equipment and wiring which is incapable of releasing sufficient electrical or thermal energy under normal or abnormal conditions to cause ignition of a specific hazardous atmospheric mixture in its most ignitable concentration. Intrinsically safe terminations and wiring may be brought into any hazardous location of any group classification for which it is accepted without requiring explosion-proof housing or other means of protection.

Hazardous locations are classified by the National Electrical Code according to the level of hazard that may exist in the area. A hazardous location is designated by its class, group and division. The class and group specify the specific hazardous substances that may exist in the classified location.

- Class I, Groups A through D – Flammable gasses
- Class II, Groups E through G – Combustible dusts
- Class III, Easily ignitable fibers or flyings

The division indicates the conditions under which the hazardous substance may be present.

- Division I—Hazardous substances exist continuously or intermittently under normal operating conditions.
- Division II – Hazardous substances exist within closed containers or systems from which they can escape only in case of accidental rupture or breakdown.

The **ARM-120-AAE** and **ARM-120-ABE** Triplex Controllers have four switch inputs and three load outputs. The inputs are designated off, lead, lag and 2nd lag. If the off switch fails to close, the lead load will not energize until both the lead and lag switches close. De-energization of the loads depends on the output logic of the selected controller.

ARM-120-AAE (SOSO): The **ARM-120-AAE** has sequence-on-simultaneous-off output logic. As the 2nd lag, lag and lead switches open, the loads remain energized. When the off switch opens, all three loads de-energize simultaneously. If any switch fails to open, the loads still de-energize when the off switch opens. The lead advances one position each time the loads de-energize.

ARM-120-ABE (FOFO): The **ARM-120-ABE** has first-on-first-off output logic. When the 2nd lag switch opens, all three loads remain energized. The lag switch opens next, and the lead load de-energizes. When the lead switch opens, the lag load de-energizes. Finally, the off switch opens, and the second lag load de-energizes. At the end of each cycle the lead advances one position for each load energized during the cycle. For example: if loads one and two cycle on and off, the lead will advance two positions. Load three will be the lead load for the next cycle.

The **ARM-120-ACE (SOSO)** and **ARM-120-ADE (FOFO)** Special Function Triplex Controllers have the same features and operations as the ARM-120-AAE and ARM-120-ABE respectively with the addition of an eight-position field selection switch. The switch allows any one load to be omitted from the sequence or locked in the lead position. An automatic test mode is also provided for system verification and troubleshooting.

LOAD OMIT MODE: One load may be omitted from the sequence for general or emergency maintenance while alternating the remaining loads.

LEAD SELECT MODE: The controller may be locked into a desired sequence to equalize motor run time.

AUTOMATIC TEST MODE: The controller energizes the loads one at a time for five second intervals.

WIRING

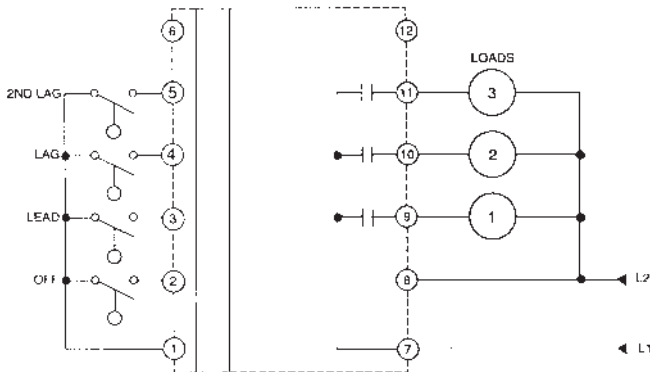

FIELD SELECTION SWITCH

POS.	FUNCTION
0	NORMAL
1	1 2 3
2	2 3 1
3	3 1 2
4	OMIT L1
5	OMIT L2
6	OMIT L3
7	TEST

OPERATION—QUADRAPLEX CONTROLLERS

The **ARM-120-AGE** and **ARM-120-AHE** Quadraplex Controllers have five switch inputs and four load outputs. The inputs are designated off, lead, lag, 2nd lag, and 3rd lag. With the off switch closed, the loads energize in sequence upon closure of the lead, lag, 2nd lag, and 3rd lag inputs. If the off switch fails to close, the lead load will not energize until both the lead and lag switches close. De-energization of the loads depends on the output logic of the selected controller.

ARM-120-AGE (SOSO): The ARM-120-AGE has sequence-on-simultaneous-off output logic. As the 3rd lag, 2nd lag, lag and lead switches open, the loads remain energized. When the off switch opens, all four loads de-energize simultaneously. If any switch fails to open, the loads still de-energize when the off switch opens. The lead advances one position each time the loads de-energize.

ARM-120-AHE (FOFO): The ARM-120-AHE has first-on-first-off output logic. When the 3rd lag switch opens, all four loads remain energized. The 2nd lag switch opens next, and the lead load de-energizes. When the lag switch opens, the lag load de-energizes. Next, the lead switch opens, and the 2nd lag load de-energizes. Finally, the off switch opens, and the 3rd lag load de-energizes. At the end of each cycle the lead advances one position for each load energized during the cycle. For example: if loads one and two cycle on and off, the lead will advance two positions. Load three will be the lead load for the next cycle.

The **ARM-120-AJE** Expandable Controller combines five inputs, four load outputs, and two field selection switches making this our most versatile alternating controller. A toggle switch selects either SOSO or FOFO output logic. A rotary switch enables alternation between two, three or four loads. Combined settings of both switches are used to omit a load or lock the controller into a desired sequence. A manual test mode is provided for system verification and troubleshooting.

MANUAL TEST MODE: The rotary selector switch has two test positions, off and lead. When the lead position is chosen, the lead load energizes. Moving the switch to the off position de-energizes the load and advances the lead one position. Turning the rotary switch between the off and lead positions cycles the controller through all four outputs. Regardless of the number of loads connected, all four outputs are exercised by the test modes.

WIRING

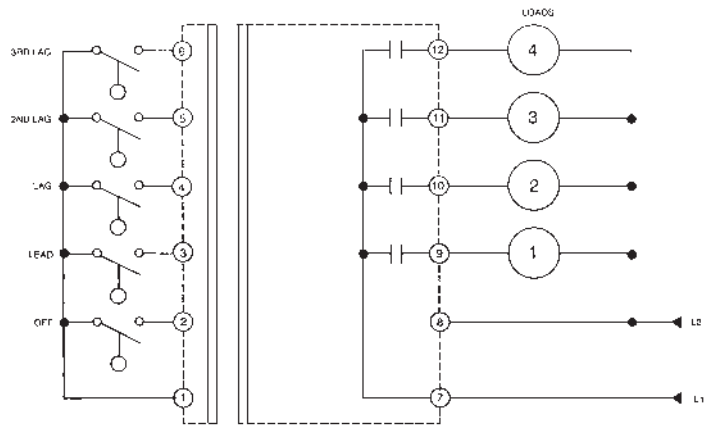

FIELD SELECTION SWITCHES (ARM-120-AJE)

ROTARY SW POS.	Toggle		MODE
	SOSO SEQ SEL	FOFO OMIT	
0	NORMAL		Quadraplex
1	1234	L1	
2	2341	L2	
3	3412	L3	
4	4123	L4	
5	NORMAL		Triplex
6	123	L1	
7	231	L2	
8	321	L3	Duplex
9	NORMAL		
A	12	L1	
B	21	L2	Test
C	OFF		
D	LEAD		
E	UNUSED		
F	OFF		

Alternating Relays & Controllers // ARM Series

SOSO OPERATION

STEP 1

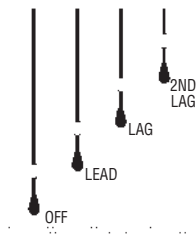

This example illustrates the normal operation of the Triplex Controller in a pump down application with four normally open-dry float switches. The switches are designated off, lead, lag, and 2nd lag. The example begins with all switches open and all loads de-energized.

STEP 2

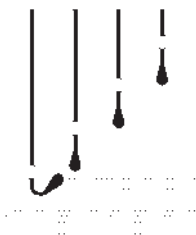

As the fluid level rises, the OFF switch closes, no loads are energized.

STEP 3

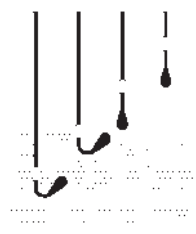

If the fluid level continues to rise, the lead switch closes and load 1 energizes.

STEP 4



As the fluid level continues to rise each successive float switch closure sequentially energizes a corresponding load.

STEP 5

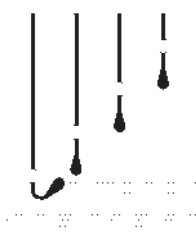

When the fluid level falls and each float switch opens, the loads remain energized so long as the OFF switch remains closed. No external auxiliary contacts are required to accomplish this latch feature.

STEP 6

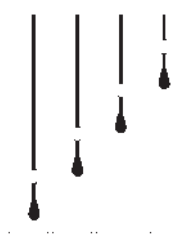

When the fluid level falls below the OFF switch, all loads simultaneously de-energize, and the alternating logic advances one position. The next rise and fall in fluid level and successive operation of load switches will result in the SOSO load operation as follows: 2-3-1, 3-1-2, and back to 1-2-3 as in Step 1.

FOFO OPERATION

STEP 1

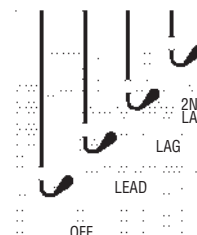

This example continues from SOSO operation step four. With all float switches closed, all loads are energized.

STEP 2



As the fluid level falls, the 2nd lag switch opens. All loads remain energized. Each float switch in descending order acts as the OFF switch for the preceding float.

STEP 3



When the lag switch opens, load 1 de-energizes. Loads 2 and 3 remain energized.

STEP 4

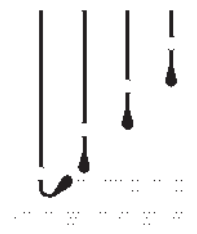

When the lead switch opens, load 2 de-energizes. Load 3 is held on by the OFF switch.

STEP 5















When the OFF switch opens, load 3 de-energizes and the lead advances three positions. At the end of each cycle the lead advances one position for each load energized during the cycle. This particular example reverts back to SOSO OPERATION 1-4 wherein load 1 would again be the lead load.

ISOLATED SWITCHES

INTRINSICALLY SAFE SINGLE & MULTIPLE CHANNEL INPUTS

Hazardous locations are classified by the National Electrical Code according to the level of hazard that may exist in the area. A hazardous location is designated by its class, group and division.

Class and group specify the type of hazardous substance that may exist in the classified location. The division indicates the conditions under which the hazardous substance may be present.

	<p>CLASS I</p> <p>Locations in which flammable gases or vapors may be present in the air in quantities sufficient to produce explosive or ignitable mixtures.</p>		<p>CLASS II</p> <p>Locations which are hazardous because of the presence of combustible dust.</p>
	<p>GROUP A</p> <p>Atmospheres containing acetylene.</p>		<p>GROUP E</p> <p>Atmospheres containing metal dust including aluminum, magnesium and their commercial alloys and other metals of similarly hazardous characteristics.</p>
	<p>GROUP B</p> <p>Atmospheres containing hydrogen, gases or vapors of equivalent hazard, such as manufactured gas.</p>		<p>GROUP F</p> <p>Atmospheres containing carbon black, coal or coke dust.</p>
	<p>GROUP C</p> <p>Atmospheres containing ethyl-ether vapors, ethylene or cyclopropane.</p>		<p>GROUP G</p> <p>Atmospheres containing flour, starch or grain dusts.</p>
	<p>GROUP D</p> <p>Atmospheres containing gasoline, hexane, naphtha, benzine, butane, propane, alcohol, acetone, benzol, lacquer solvent vapors or natural gas.</p>		<p>CLASS III</p> <p>Locations which are hazardous because of the presence of easily ignitable fibers or flyings, but in which such fibers or flyings are not likely to be in suspension in air in quantities sufficient to product ignitable mixtures.</p>
	<p>DIVISION I</p> <p>Locations in which hazardous concentrations in the air exist continuously, intermittently or periodically under normal operating conditions.</p>		<p>DIVISION II</p> <p>Locations in which hazardous concentrations are handled, processed or used but are normally confined within closed containers or closed systems from which they can escape only in case of accidental rupture or breakdown.</p>



The ATC Diversified Electronics series of Isolated Switches have been tested and approved for listing under Underwriters Laboratories (UL) UL913 Intrinsically Safe Apparatus and Associated Apparatus. The input(s) to these switches have been approved for use in all classes, groups and divisions of hazardous locations.

Sold by AA Electric 1-800-237-8274 Lakeland, FL • Lawrenceville, GA • Greensboro, NC • East Rutherford, NJ
 Web : www.A-Aelectric.com Email : njsales@a-aelectric.com