

FF-SRS5935 Dual Channel Emergency Stop Module

FF-SRS5935

FEATURES

- Complies with the Machinery Directive 98/37/EC, IEC 204, EN 60204, DIN VDE 0113 and UL 508
- Output: three NO contacts and one NC contact for AC 250 V
- Gold plated, 5µm contacts allow accurate low current to PLC (PLC is NOT to be used as a safety function)
- Dual channel connection
- Line fault detection and detection of blocked start push-button
- Automatic restart or start/restart interlock modes of operation
- Selectable cross fault detection in emergency stop control circuit
- Operating status display
- LED indicates power and channels one and two (internal relays) status
- Mechanical life up to ten million operations
- Electrical life up to one million operations
- Switching current up to 10A
- Voltage drop protection
- Removable terminal strips for ease of maintenance
- 45 mm (1.77 in.) width

APPLICATIONS

- Two channel emergency stop circuits on machines
- Point-of operation protection
- Door protection
- Perimeter/zone guarding protection
- Conveyors/transfer lines



The FF-SRS5935 Emergency Stop modules are designed to be used in emergency stop circuits when danger to personnel or machinery is present. This device has two safety relays with positive-guided contacts to ensure redundancy.

This module contains two internal switches (S1 and S2) that are used to set various modes of operation. This feature ensures application flexibility. In the **start/restart interlock mode**, the module accepts input from the safety device (light curtain, safety mat, safety switches, etc.) between S11/S12 and S21/S22 after activation of the push-button between S33 and S34; then, the normally open safety contacts (13/14, 23/24, 33/34) will close and the normally closed contact (41/42) will open.

In the **automatic restart mode**, the module accepts immediate input from the safety device (light curtain, mat, safety switches, etc.) between S11/S12 and S21/S22 (S33 and S34 are jumpered if external relay monitoring is not needed); then normally open safety contacts (13/14, 23/24, 33/34) will close and the normally closed contact (41/42) will open.

In either mode, if the safety device is actuated (emergency stop condition occurs), the normally open contact will open immediately and the normally closed contact will close. This emergency stop condition is relayed via the safety contacts of the module to the machine control circuitry to arrest dangerous motion and/or remove power.

Cross fault monitoring must be used when two independent safety inputs are provided to this module to increase the overall safety level of the solution (see typical application examples).

WARNING

MISUSE OF DOCUMENTATION

- The information presented in this product sheet (or catalogue) is for reference only. DO NOT USE this document as system installation information.
- Complete installation, operation and maintenance information is provided in the instructions supplied with each product.

Failure to comply with these instructions could result in death or serious injury.

FF-SRS5935 Dual Channel Emergency Stop Module

SPECIFICATIONS

- Dual channel Emergency Stop circuits



Input	Nominal voltage	120 Vac (-15%, +10%), 230 Vac (-15%, +10%), 24 Vdc (-10%, +20%)
	Nominal power consumption	24 Vdc: 2 W; 230 Vac: 4 VA
	Nominal frequency	50 to 60 Hz
	Start time	Manual START function; 50 ms (-25%, +50%); Automatic START function; 1 s (-25%, +50%)
	Nominal voltage between S11/S12 and S21/S22	24 Vdc with 35 mA current ± 25% (provided by control module)
	Minimum voltage between S11/S12 and S21/S22	21 Vdc when activated
	Cable resistance between S11/S12 and S21/S22	68 Ω (max.)
Output	Contact complement	3 NO contacts, 1 NC contacts
	Response time	After opening of input S12/11 or S21/22): 25 ms; Opening in supply circuit (L1(+)/A1): 50 ms
	Contact type	Safety relay, positive-guided
	Switching Capability	Power factor = 1 with resistive load
	Current Range (min. to max.)	1 mA to 10A (Note 1)
	Voltage Range (min. to max.)	0.1 to 250 Vac/dc
	Switching capability per AC15 (EN 60947-5.1)	NO contact: 5A / 250 Vac - NC contact: 2A / 250 Vac
	Typical Electrical Life Expectancy	Power factor = 1 at 230 Vac (Note 2)
	3A	1,000,000 operations
	5A	500,000 operations
	10A	220,000 operations
	Typical Power Factor (cos φ)	Limitation Factor (Note 3)
	0.3	0.45
	0.5	0.70
	0.7	0.85
	1.0	1.00
	Operating frequency	600 switching cycles/h
	Fuse Rating	6 A time delayed
	Mechanical life	Ten million switching operations
General	Temperature range	-15°C to +55°C (5°F to 131°F) at max. 90% humidity (max.)
	Sealing	Housing IP 40; Terminals IP 20
	Housing material	Thermoplastic
	Vibration resistance	Amplitude 0.35 mm; Frequency 10 to 55 Hz
	Conductor connection	1 x 4 mm ² solid (max.) [12 AWG] or 2 x 1.5 mm ² (max.) [16 AWG] stranded wire with sleeve DIN 46288
	Conductor attachment	Removable block terminals with M 3.5 screws; wire contacts are enclosed to prevent electrical shock
	Mounting	Quick install rail mounting EN 50022-35
	Weight	450 g (0.99 lb.)

ORDERING INFORMATION

FF-SRS5935 □

Voltage:
2 = 24 Vdc
E = 120 Vac
G = 230 Vac

Note 1: To ensure the 1 mA capability during the lifetime of the contact, NEVER exceed 300 mA or 60 V.

Note 2: Install arc suppression device across load to avoid module contact arcing and ensure specified relay life expectancy.

Note 3: Total operations = Operations at power factor 1 multiplied by the limitation factor. If the power factor is 0.5 at 230 Vac, 3A (1,000,000 operations), the limitation factor is 0.70. 1,000,000 x 0.70 = 700,000 total operations.

CONTACT LIFE FOR 100% RESISTIVE LOAD (TYPICAL)

power factor = 1 (cos φ)

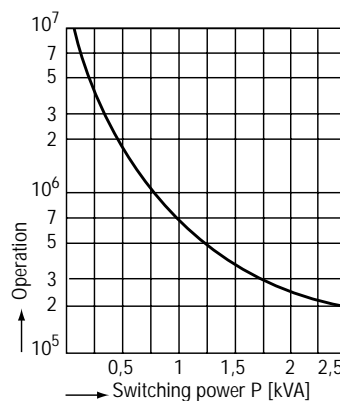

LIMITATION FACTOR FOR INDUCTIVE LOADS

power factor < 1 (cos φ)

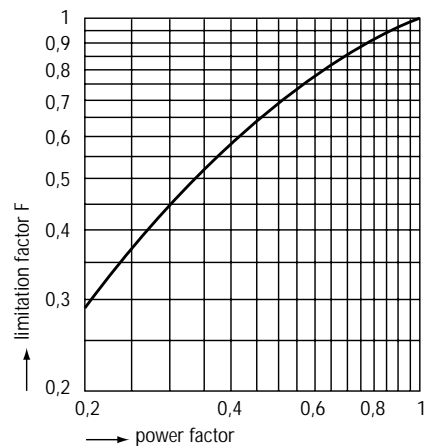

INSTALLATION DIAGRAM

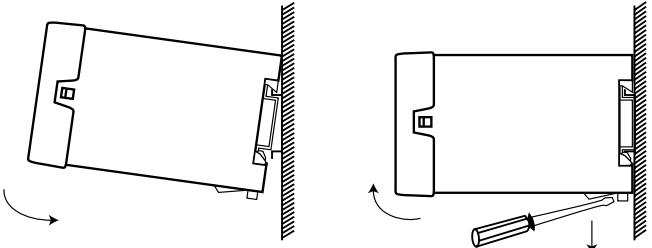

MOUNTING DIMENSIONS

Width: 45 mm/1.77 in; Height: 74 mm/2.91 in; Depth: 121 mm/4.76 in

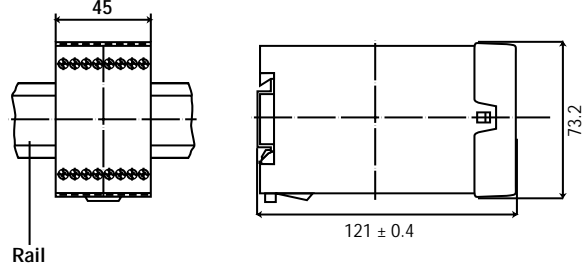

INTERNAL CIRCUITRY

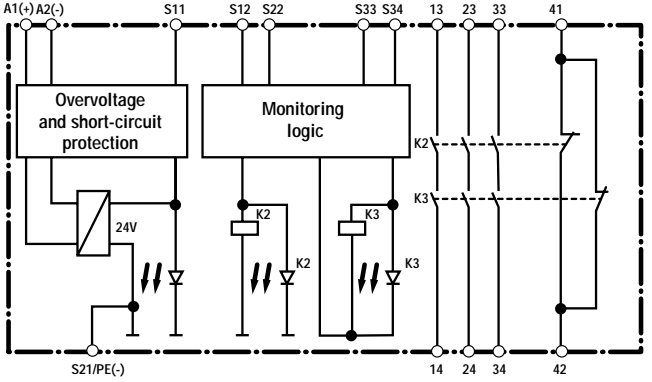

WIRING DIAGRAM

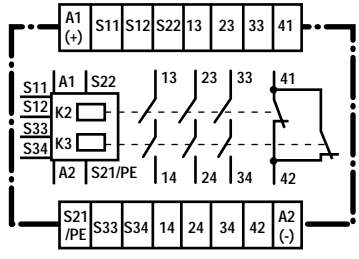

FF-SRS5935 PROGRAMMING: Switch Settings

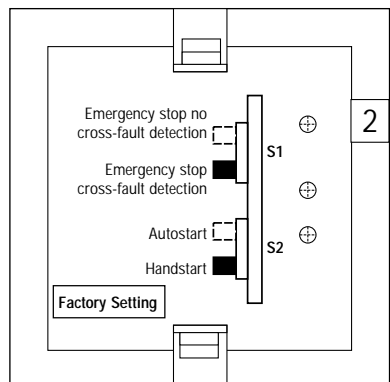
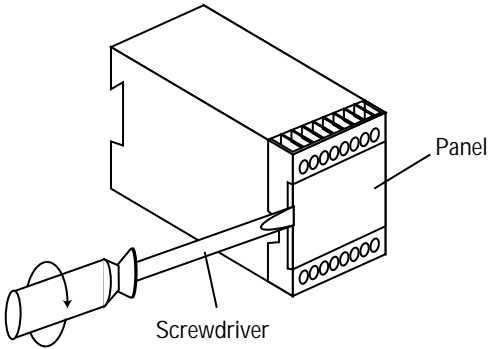

Switches S1 and S2 are used to select **automatic start**, **manual start** and emergency stop with or without **cross fault detection**. These switches are located behind the front cover panel.

Switch S2 is used to select automatic or manual start. In addition, terminals S33 and S34 must be shunted for automatic start to function.

Switch S1 is used to select an operating mode for cross fault detection between the two inputs and push-button failure.

The emergency stop module must be connected as illustrated in the following application examples.

FUNCTIONAL DIAGRAM

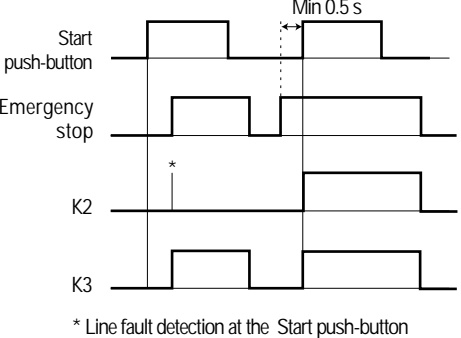

FUNCTIONAL DESCRIPTION

If the start push-button is closed before voltage is applied to S12 and S22 (also, if a line fault occurs via the start push-button), the output contacts cannot be switched to START.

The module's PE testing terminal allows insulation monitoring on IT networks. This terminal serves as a reference point for checking the control voltage and provides a connection contact during an emergency stop with cross fault detection.

Notice that connecting the PE terminal to ground on DC versions implies the deactivation of the internal short-circuit protection.

One or more FF-SRE3081 Extension Modules or external contactors with positively driven contacts can be used to multiply the number of contacts of the FF-SRS5935 Emergency Stop Module. If multiple safety contacts are used in parallel with one load, the maximum admissible current can be increased.

APPLICATION SCHEMATICS

Dual-channel emergency stop circuit with cross fault detection (recommended interface)

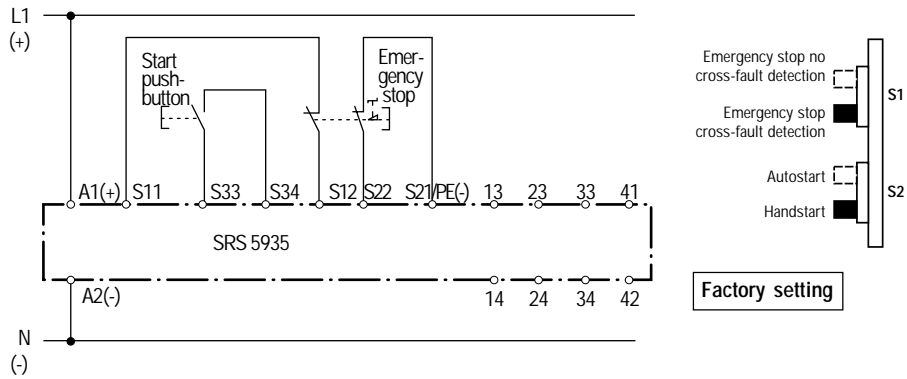

The circuit redundancy in the emergency stop control circuit and therefore gives the highest safety level.

Single-channel emergency stop circuit

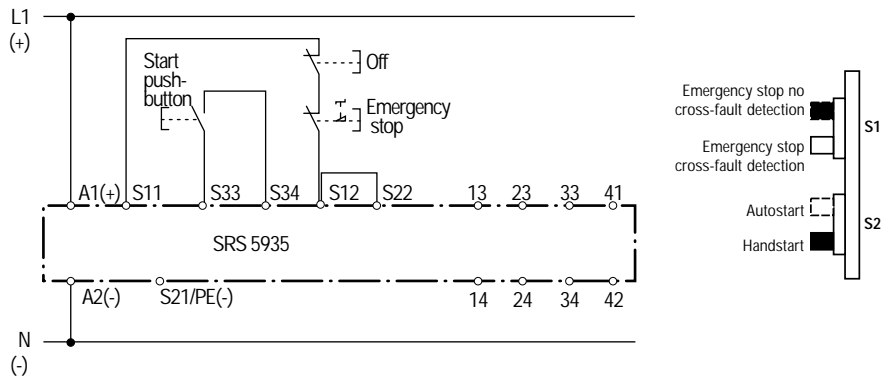

This circuit has no redundancy in the emergency stop circuit.

Dual-channel emergency stop circuit without cross fault detection

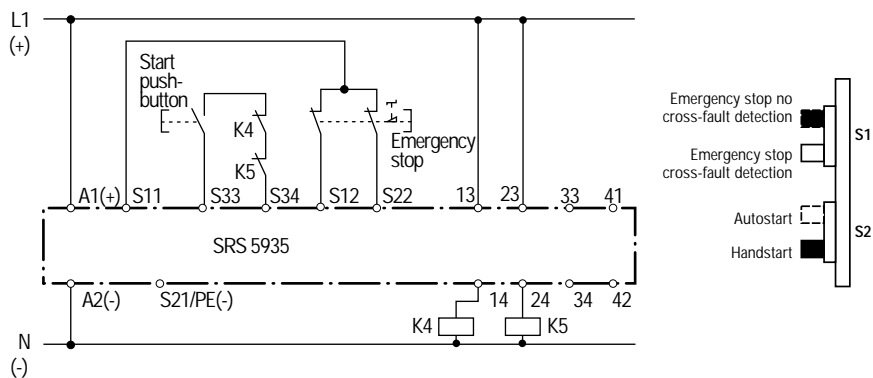

With switching current >10 A, the output contacts should be reinforced by external contactors (K4 and K5) with positive-guided contacts. The proper operation of the external contactors is monitored by looping NC contacts into the restart circuit (terminals S33-S34).