

**DC Series  
Tubeaxial  
Cooling Fans  
Model No. D47T15**

**4.69" Sq. x 1.50"  
(119 mm Sq. x 38 mm)  
97-108 CFM  
(45.8-51.0 L/Sec.)**



**Features**

- Solid-state brushless motor design provides:
  - Auto restart
  - Low input power
  - Lower operating voltages
- Precision ball bearing system provides:
  - Longer life
  - Higher temperature extremes
  - Lower noise over time
  - Maximum shock and vibration resistance
- Designed to meet the rigid standards of UL, CSA, VDE, and CE.

**Accessories:**

- Finger guards
- Filters

**General Specifications**

- Frame:** Reinforced polybutylene plastic (UL94V-0 flame retardant)
- Impeller:** Reinforced polybutylene plastic (UL94V-0 rating)
- Bearings:** Precision, life-lubricated ball bearings
- Insulation:** Class A integral ground system rated @ 248°F (120°C)
- Weight:** 9.2 ozs. (260 grams)
- Operating Temperature Range:** 14° to 158°F (-10° to 70°C)
- Insulation Resistance:** 10 megohms minimum @ 500 VDC
- Dielectric Strength:** 500 VAC for 60 seconds
- Safety Protection:** Electronic locked rotor protected; polarity protected
- Life Expectancy:** 75,000 hours minimum @ 77°F (25°C)
- Options:** (Consult Factory)
  - Tachometer output
  - Locked rotor sensor output (Not available on 48 VDC)

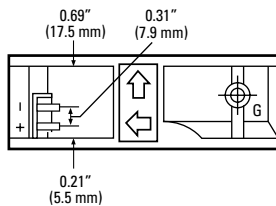

**Terminals**

- 2 Solder Terminals
- Centers: .312" (7.92 mm)
- Thickness: .02" (.51 mm)
- Width: .120" (3.05 mm)
- Length: .31" (7.8 mm)

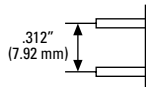

**RED LEAD IS POSITIVE (+)  
BLACK LEAD IS NEGATIVE (-)  
WHITE LEAD IS TACHOMETER/SENSOR**

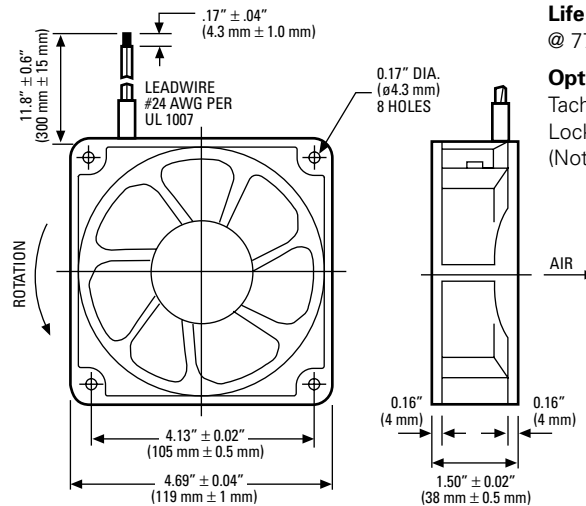

Globe Motors Part Number	Nominal Voltage VDC	Voltage Operating Range VDC	Watts	Line Amps	RPM	Acoustic Noise dBA	Airflow (Min.)	
							CFM	Liters per Second
<del>D47-B15A-04T2-100</del>	12	6.0 / 13.8	4.80	0.40	2650	41	97	45.8
D47-B15A-04W2-100	12	6.0 / 13.8	4.80	0.40	2650	41	97	45.8
D47-B15A-04T3-100	12	6.0 / 13.8	6.60	0.55	2950	43	108	51.0
D47-B15A-04W3-100	12	6.0 / 13.8	6.60	0.55	2950	43	108	51.0
D47-B15A-04T4-100	12	6.0 / 13.8	8.40	0.70	3200	46	118	55.7
<del>D47-B15A-04W4-100</del>	12	6.0 / 13.8	8.40	0.70	3200	46	118	55.7
D47-B15A-05T2-100	24	10.0 / 27.6	5.04	0.21	2650	41	97	45.8
D47-B15A-05W2-100	24	10.0 / 27.6	5.04	0.21	2650	41	97	45.8
D47-B15A-05T3-100	24	10.0 / 27.6	7.44	0.31	2950	43	108	51.0
D47-B15A-05W3-100	24	10.0 / 27.6	7.44	0.31	2950	43	108	51.0
D47-B15A-05T4-100	24	10.0 / 27.6	8.40	0.35	3200	46	118	55.7
D47-B15A-05W4-100	24	10.0 / 27.6	8.40	0.35	3200	46	118	55.7
D47-B15A-07T3-100	48	25.0 / 55.2	7.68	0.16	2950	43	108	51.0
<del>D47-B15A-07W3-100</del>	48	25.0 / 55.2	7.68	0.16	2950	43	108	51.0

\*Note: For tachometer output models, substitute "B" in part number. Part Number D47-B15"A"-04W2-100 would change to D47-B15"B"-04W2-100. Minimum order quantity may apply.  
For locked rotor sensor output models, substitute "C" in part number. Part Number D47-B15"A"-04W2-100 would change to D47-B15"C"-04W2-100. Minimum order quantity may apply.

## Installation Guide

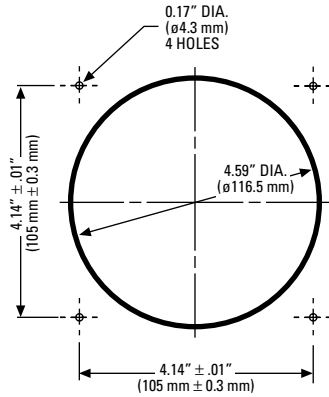

## Performance at Sea Level

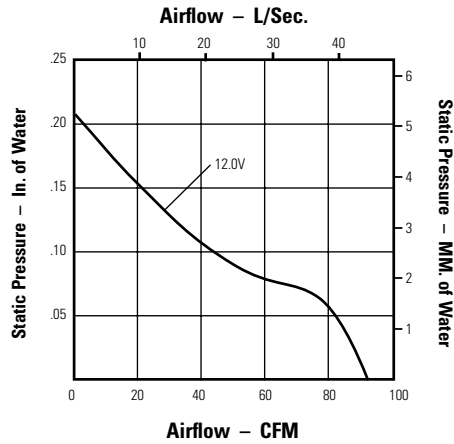

D47-B15A-04W2-100

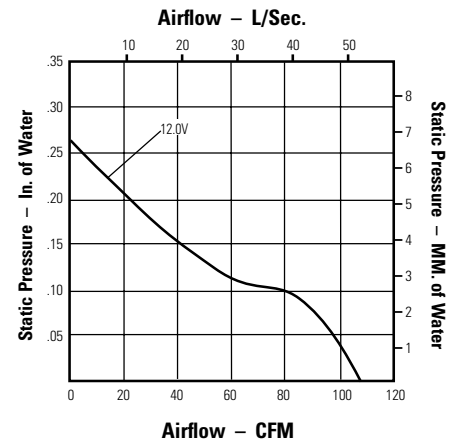

D47-B15A-04W3-100

## Approvals



UL File No.  
E105397



CSA File No.  
72877



VDE File No.  
17074-2611-0701

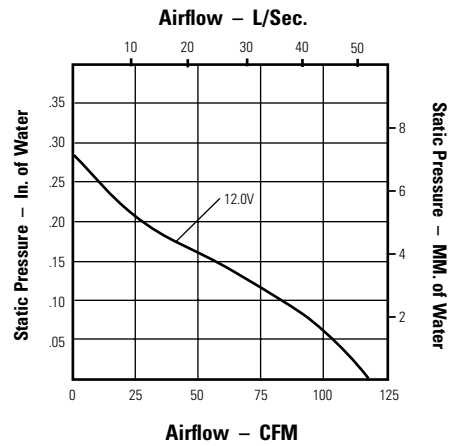

D47-B15A-04W4-100

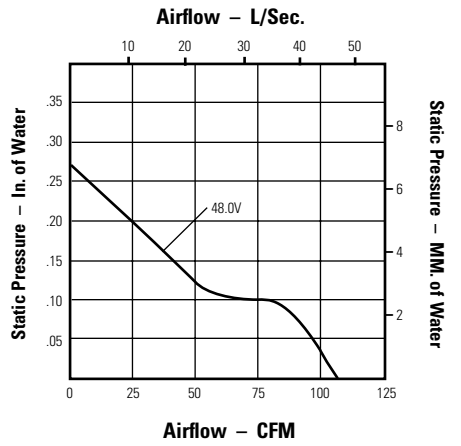

D47-B15A-07W3-100

## Tachometer Output (Open Collector Circuit)

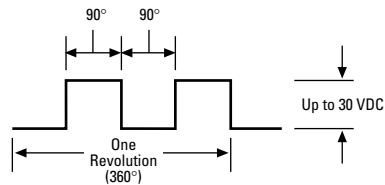

## Locked Rotor Output (Open Collector Circuit)

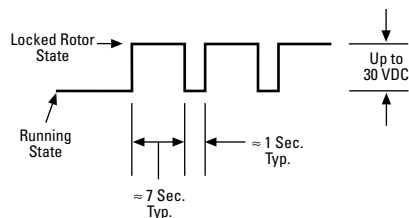

All operating specifications measured at nominal operating voltage, free air at sea level

24 volt performance is identical to 12 volt fan performance

## NOTES: