

1702/1703

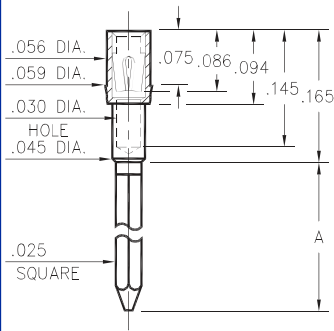

Basic Part Number	# of Wraps	Length A
1702-2	2	.370
1703-3	3	.510

170X-X-17-XX-30-XX-02-0
Press-fit in .057 mounting hole

0038⇒0040/0066⇒0068

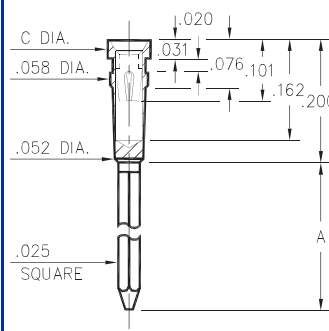

Basic Part #	# of Wraps	Length A	Dia. C
0040-1	1	.260	
0039-2	2	.360	.072
0038-3	3	.500	
0068-1	1	.260	
0067-2	2	.360	.062
0066-3	3	.500	

00XX-X-17-XX-30-XX-02-0
Press-fit in .055 mounting hole

0086/0088/0089

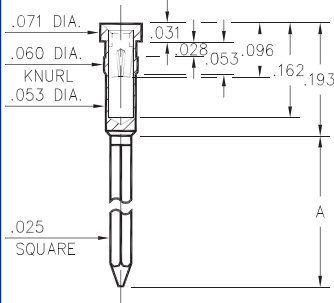

Basic Part Number	# of Wraps	Length A
0089-2	2	.370
0088-3	3	.510
0086-4	4	.630

008X-X-17-XX-3X-XX-02-0
Press-fit in .057 mounting hole

1030⇒1036

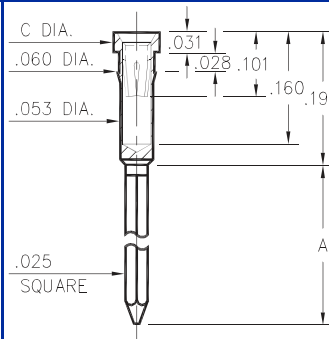

Basic Part #	# of Wraps	Length A	Dia. C
1032-1	1	.260	
1031-2	2	.360	.072
1030-3	3	.510	
1036-1	1	.260	
1035-2	2	.360	.062
1034-3	3	.510	

103X-X-17-XX-3X-XX-02-0
Press-fit in .057 mounting hole

1045

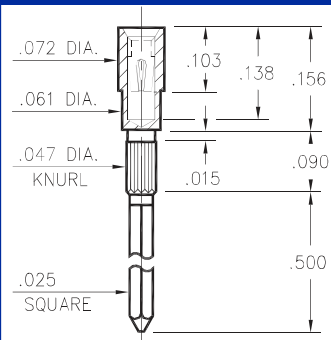

1045-3-17-XX-30-XX-02-0
Press-fit in .043 mounting hole

1040

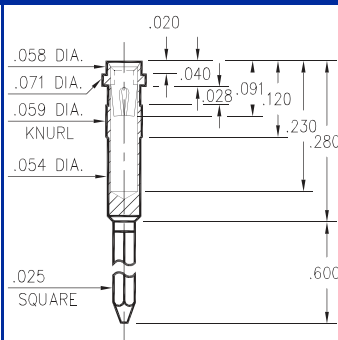

1040-3-17-XX-30-XX-02-0
Press-fit in .056 mounting hole

SPECIFICATIONS

SHELL MATERIAL:
Brass Alloy 360, 1/2 Hard

CONTACT MATERIAL:
Beryllium Copper Alloy 172, HT

DIMENSION IN INCHES
TOLERANCES ON:
LENGTHS: ±.005
DIAMETERS: ±.002
ANGLES: ± 2°

ORDER CODE: XXXX - X - 17 - XX - XX - XX - 02 - 0

BASIC PART # →

SPECIFY SHELL FINISH:
01 200μ" TIN/LEAD OVER NICKEL
◇ 80 200μ" TIN OVER NICKEL (RoHS)
◇ 15 10μ" GOLD OVER NICKEL (RoHS)

SPECIFY CONTACT FINISH:
02 100μ" TIN/LEAD OVER NICKEL
◇ 84 100μ" TIN OVER NICKEL (RoHS)
◇ 27 30μ" GOLD OVER NICKEL (RoHS)



SELECT CONTACT

#30 or #32 CONTACT (DATA ON PAGE 219)