

0305

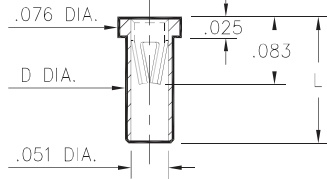

Basic Part Number	Length L	Dia. D
0305-0	.095	.056
0305-1	.105	.058
0305-2	.155	.058

T&R Packaging

Basic Part Number	Tape Width	Parts per 13" Reel
0305-0	8mm	6,000
0305-1	8mm	6,000
0305-2	24mm	1,500

0305-X-15-XX-47-XX-10-0

Solder mount in .059/.061 mounting hole
Also available on 8mm or 24mm wide carrier tape: See chart for Details.
Order as: 0305-X-57-XX-47-XX-10-0

0279

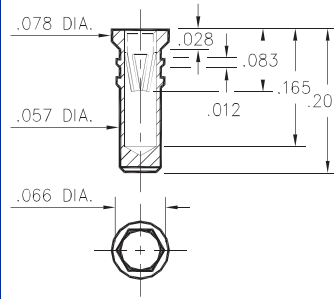

0279-0-15-XX-47-XX-10-0

Hex press-fit in .062 plated thru hole

0330

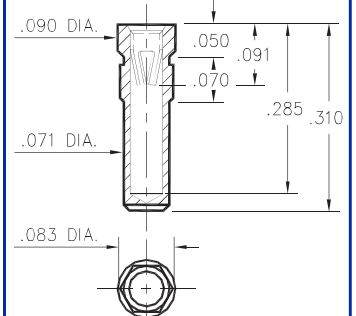

0330-0-15-XX-47-XX-10-0

Hex press-fit in .079 plated thru hole

0300/8300

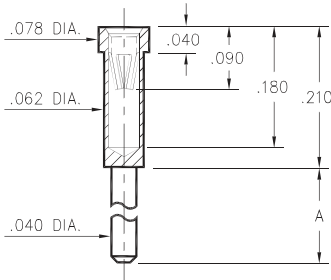

Basic Part Number	Length A
0300-1	.110
0300-2	.187
8300-0	.140

X300-X-15-XX-47-XX-10-0

Solder mount in .042 min. mounting hole

0301

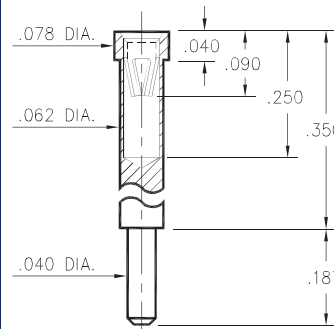

0301-1-15-XX-47-XX-10-0

Solder mount in .042 min. mounting hole

0309

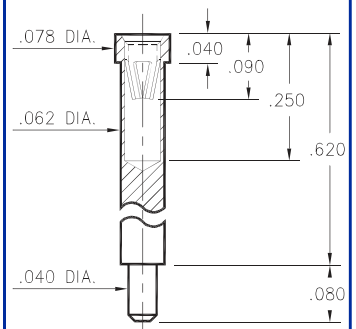

0309-2-15-XX-47-XX-10-0

Solder mount in .042 min. mounting hole

0399

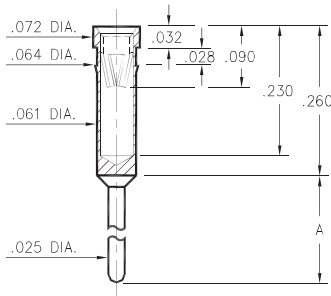

Basic Part Number	Length A
0399-0	.230
0399-1	.180

0399-X-15-XX-47-XX-04-0

Press-fit in .062 mounting hole

1304

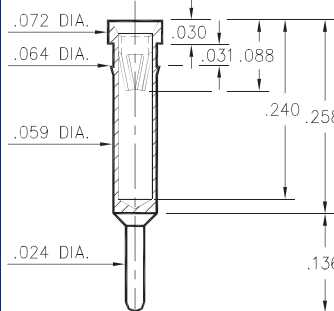

1304-0-15-XX-47-XX-04-0

Press-fit in .061 mounting hole

1134

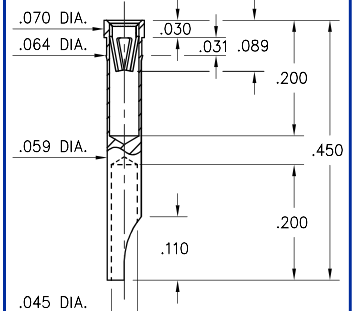

1134-0-18-15-47-27-10-0

Press-fit in .061 mounting hole

SPECIFICATIONS

SHELL MATERIAL:
Brass Alloy 360, 1/2 Hard

CONTACT MATERIAL:
Beryllium Copper Alloy 172, HT

DIMENSION IN INCHES
TOLERANCES ON:
LENGTHS: ±.005
DIAMETERS: ±.002
ANGLES: ± 2°

ORDER CODE: XXXX - X - 15 - XX - 47 - XX - XX - 0

BASIC PART #

SPECIFY SHELL FINISH:

- 01 200µ" TIN/LEAD OVER NICKEL
- ◇ 80 200µ" TIN OVER NICKEL (RoHS)
- ◇ 15 10µ" GOLD OVER NICKEL (RoHS)

SPECIFY CONTACT FINISH:

- 01 200µ" TIN/LEAD OVER NICKEL
- ◇ 80 200µ" TIN OVER NICKEL (RoHS)
- ◇ 27 30µ" GOLD OVER NICKEL (RoHS)



CONTACT

#47 CONTACT (DATA ON PAGE 222)