

- Series 510, 511, 514, 515, 522 & 523 PGA sockets are available on .100" centers.
- Series 513 and 518 PGA sockets are available for Interstitial patterns.
- Choice of three low force clips to cover all applications.
- Hi-Temp PCT polyester insulator material suitable for all forms of soldering.

For RoHS compliance
select ◇ plating code.

For Electrical,
Mechanical & Environmental
Data, See pg. 112

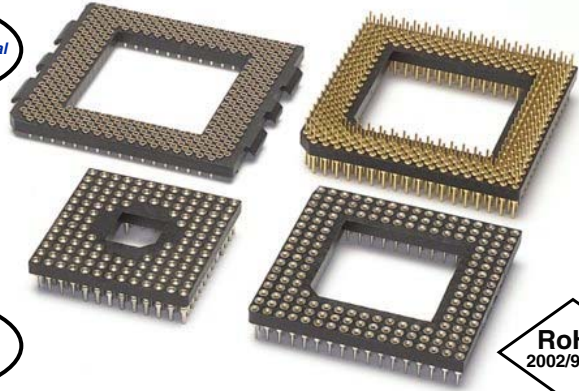

XX=Plating Code
See Below



STANDARD SOLDER TAIL SERIES 510

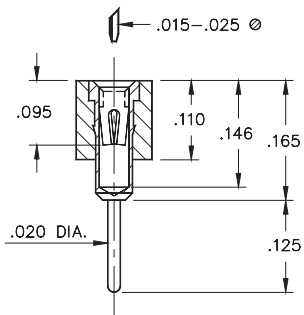

LONG SOLDER TAIL SERIES 511

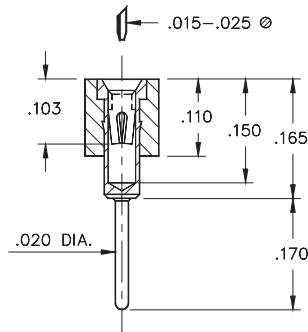

SMT RECEPTACLE SERIES 513

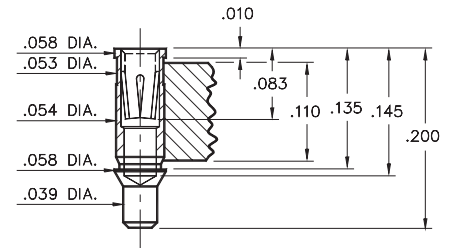

Interstitial Patterns Only

SMT RECEPTACLE SERIES 514

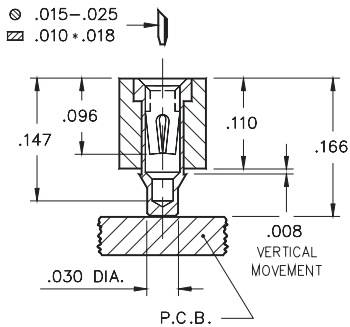

LOW PROFILE SOLDER TAIL SERIES 515

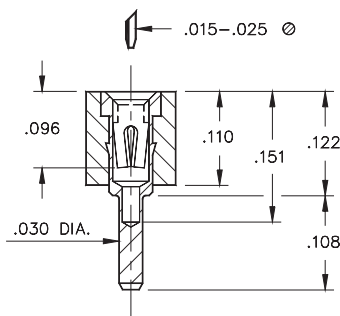

SOLDER TAIL (Without Heatsink Tabs) SERIES 518

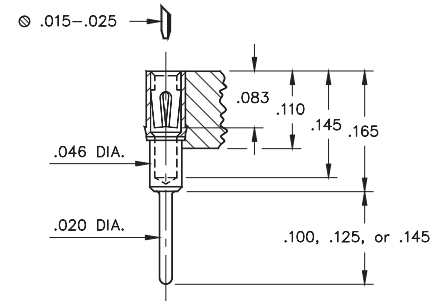

Interstitial Patterns Only

SOLDER TAIL (With Heatsink Tabs) SERIES 518

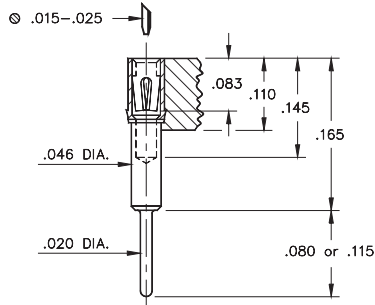

Interstitial Patterns Only

2 LEVEL WRAPOST SERIES 522

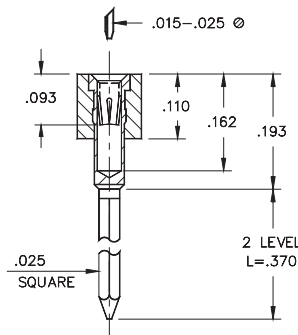

3 LEVEL WRAPOST SERIES 523

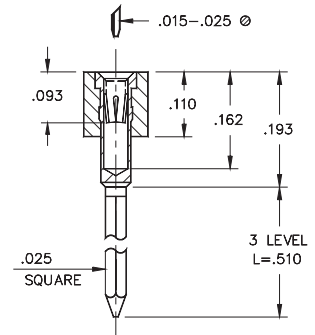

Visit www.mill-max.com/pga
To configure a formal Part Number

SPECIFY PLATING CODE XX=	13 ◇	93	43 ◇
Sleeve (Pin)	10μ" Au	200μ" Sn/Pb	200μ" Sn
Contact (Clip)	30μ" Au	30μ" Au	30μ" Au