

THIS DOCUMENT IS THE PROPERTY OF
KEYSTONE ELECTRONICS CORP. AND
SHALL NOT BE REPRODUCED, DISTRIBUTED
OR USED AS A BASIS FOR MANUFACTURE
WITHOUT PRIOR WRITTEN PERMISSION
FROM KEYSTONE ELECTRONICS CORP.

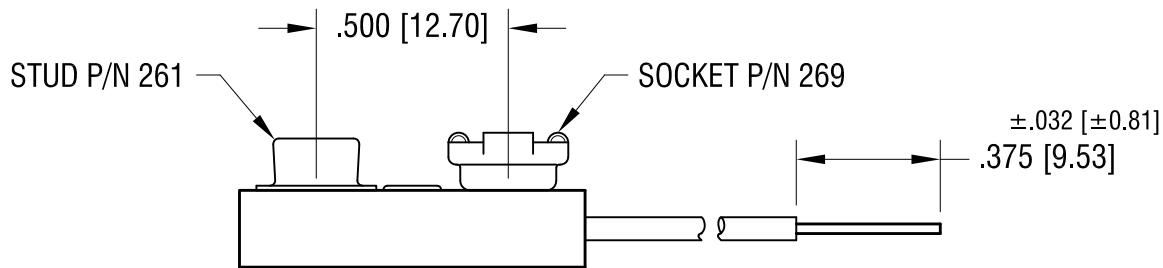
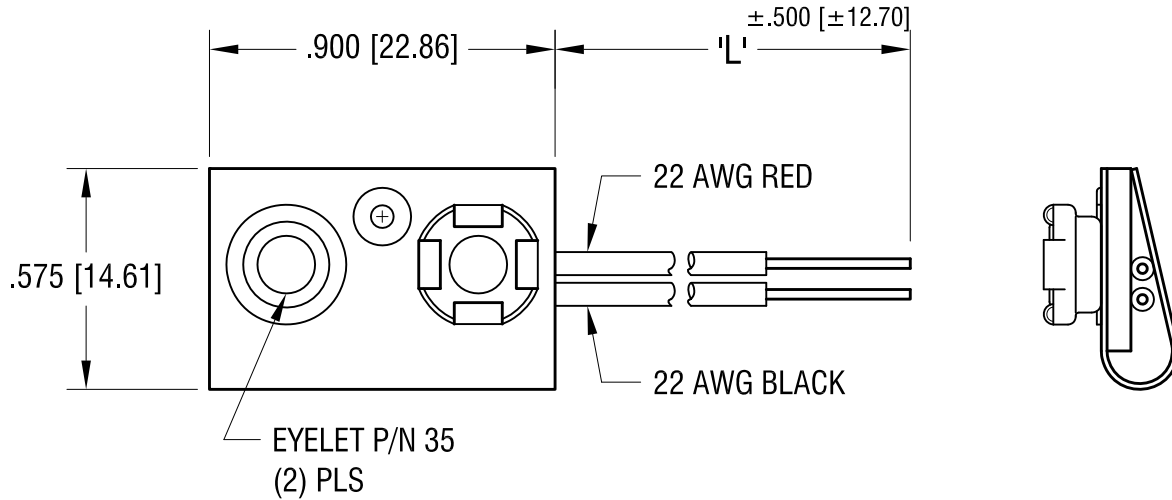

NOTES:

1. MAT'L -

WIRE: 22 AWG, 1061 UL/CSA APPROVED
.052 [1.32] O.D. PVC INSULATION.
RED WIRE SOLDERED TO FEMALE CONTACT;
BLACK WIRE TO MALE CONTACT.

2. BASE:

MAT'L - .062 [1.57] TH'K FIBRE

COVER:

MAT'L - .015 [0.38] TH'K FIBRE

CONTACT:

MAT'L - STEEL

FINISH - NICKEL PLATE

EYELET:

MAT'L - BRASS

FINISH - TIN PLATE

PART NO.	'L' DIM.
83-4	4.000 [101.60]
83	6.500 [165.10]
83-8	8.000 [203.20]

KEYSTONE ELECTRONICS CORP.

www.keyelco.com • ASTORIA, N.Y. 11105-2017 • Tel (718) 956-8900

PART NAME

'9' VOLT BATTERY STRAP

MATERIAL

AS NOTED

FINISH

AS NOTED

DRN BY

BOONE

DATE

5.17.96

APP'D

LN

SCALE

2X

TOLERANCES

INCH [MM]

DECIMAL ±.010 [±0.25]

ANGULAR ± 1°

UNLESS OTHERWISE SPECIFIED

CODE

C

DWG NO.

83-

DATE

DESCRIPTION

REV.