

Agilent 11713B/C Attenuator/Switch Drivers

Configuration Guide

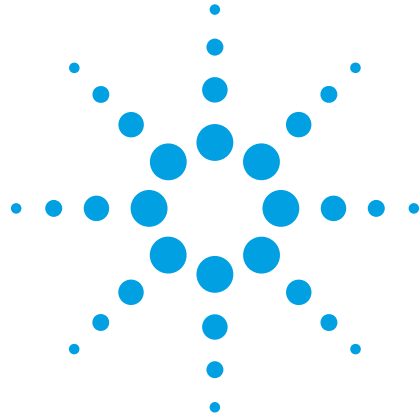

This configuration guide will assist you through the process of configuring a switching system using the Agilent 11713B/C attenuator/switch drivers.

Key Features

The 11713B attenuator/switch driver is a GPIB compatible instrument that concurrently drives up to two four-section programmable step attenuators and two microwave coaxial switches, or up to 10 SPDT switches². The 11713B is fully backward compatible with the 11713A in terms of functionality and fit. Connectivity using USB and LAN are optional.

The 11713C attenuator/switch driver is a GPIB/USB/LAN compatible instrument that concurrently drives up to four programmable step attenuators and four microwave coaxial switches, or up to 20 SPDT switches². The 11713C comes with tri-voltage selection of 5V, 15V and 24V and also permits user-defined voltage supply capability.

- Programming via GPIB/USB can be accomplished in simple one-line statements.
- Control the attenuator/switch drivers through LAN using a web-based interface.
- An integrated LCD display eases menu selection and instrument configuration.
- Inclusion of solenoid arc suppression diodes with three pre-defined common terminal supplies allow the instrument to be used with wide variety of attenuators and switches.

Key features	11713B	11713C
Manually-controlled using front panel push buttons	Yes	Yes
Automatically-control through: <ul style="list-style-type: none"> • GPIB • USB • LAN 	Yes Optional Optional	Yes Yes Yes
Integrated LCD display	Yes	Yes
Self-contained power supply with current limiting	Yes	Yes
Common terminal supplies of <ul style="list-style-type: none"> • +5 Vdc • +15 Vdc • +24 Vdc • User-defined 	No No Yes No	Yes Yes Yes Yes
TTL control	No	Yes

Note 1: 11713B/C attenuator/switch drivers output continuous current and do not support pulse drive. Please ensure your switching devices can withstand continuous current or have a built-in current interrupt feature.

Note 2: The amount of switches and attenuators that can be driven will depend on the type of switch configuration and attenuator section configuration. The 11713C can drive twice as many devices as the 11713B; however, the total load current that can be consumed is still 1.7A.

Specifications

Drive power supply specifications

Specifications below describe warranted performance over the temperature range of 0 to 50 °C after one hour of continuous operation, unless otherwise noted.	
Voltage	+24 ± 8% Vdc
	+5 ± 5% Vdc
	+15 ± 12% Vdc
Current	1.7 A maximum continuous current
	Contact pairs 1 through 8, 9 and 0, maximum current of 0.7 A per contact

Supplemental characteristics

Supplemental characteristics are intended to provide useful information and are typical but non-warranted performance parameters.	
Power	100 or 240 Vac, automatic selection, 50/60 Hz
	100 VA maximum
Response time	100 µs maximum for contact pairs 1 through 8
	20 ms maximum for contact pairs 9 and 0
Driver life	2,000,000 switchings at 0.7 A for contact pairs 9 and 0
Maximum load inductance	500 mH
Maximum load capacitance	< 0.01 µF for contact pairs 9 and 0

Physical specifications

Net weight	3.2 kg (7.1 lbs)
Dimensions (H x W x D) with handle and rubber bumper	130 mm x 250 mm x 462 mm (5.1 inches x 9.8 inches x 18.2 inches)
Dimensions (H x W x D) without handle and rubber bumper	88 mm x 212 mm x 348 mm (3.5 inches x 8.5 inches x 13.7 inches)

Product Configurations

The 11713B/C attenuator/switch drivers can be configured easily. The connection between the driver and switching devices is intuitive and direct. Simply select the appropriate interface cable and you can make point-to-point connection from the driver to the attenuator(s) and/or switch(es). Details such as pin numbers and wires color are provided in the tables found in *Configuration Information for Switches* and *Configuration Information for Attenuators* sections.

Note 1: The maximum quantity orderable for each cable option is 9.

11713B		
Connectivity options		
Option STD		Standard configuration, full backward compatibility to 11713A
Option LXI		LXI Class-C configuration, additional USB/LAN connectivity, full backward compatibility to 11713A
Cable options		
Option	Part number	
Option 001	11764-60004	Viking connector to 10-pin DIP connector
Option 101	8120-2703	Viking connector to viking connector
Option 201	5061-0969	Viking connector to 12-pin conductor cable, bare wire
Option 301	11761-60001	Viking connector to 4 ribbon cables
Option 401	11713-60042	Dual-viking connector to 16-pin DIP connector
Option 501	11713-60043	Viking connector to (4) 9-pin Dsub connectors
Option 601	11713-60044	Viking connector to 16-pin DIP connector
Option 701	5064-7848	Viking connector to 14-pin DIP connector
Option 801	11713-60047	Viking connector to (4) 10-pin DIP connectors
Rack mount kit options (optional)		
Option 908	5063-9240	Rack mount kit for one instrument
Option 909	5061-9496 & 5063-9212	Rack mount kit for two instruments

11713C		
Cable options		
Option	Part number	
Option 001	11764-60004	Viking connector to 10-pin DIP connector
Option 101	8120-2703	Viking connector to viking connector
Option 201	5061-0969	Viking connector to 12-pin conductor cable, bare wire
Option 301	11761-60001	Viking connector to 4 ribbon cables
Option 401	11713-60042	Dual-viking connector to 16-pin DIP connector
Option 501	11713-60043	Viking connector to (4) 9-pin Dsub connectors
Option 601	11713-60044	Viking connector to 16-pin DIP connector
Option 701	5064-7848	Viking connector to 14-pin DIP connector
Option 801	11713-60047	Viking connector to (4) 10-pin DIP connectors
Rack mount kit options (optional)		
Option 908	5063-9240	Rack mount kit for one instrument
Option 909	5061-9496 & 5063-9212	Rack mount kit for two instruments

Cable and rack mount kit can be ordered separately with the part numbers below.		
11713B-001/11713C-001		Viking connector to 10-pin DIP connector
11713B-101/11713C-101		Viking connector to viking connector
11713B-201/11713C-201		Viking connector to 12-pin conductor cable, bare wire
11713B-301/11713C-301		Viking connector to 4 ribbon cables
11713B-401/11713C-401		Dual-viking connector to 16-pin DIP connector
11713B-501/11713C-501		Viking connector to (4) 9-pin Dsub connectors
11713B-601/11713C-601		Viking connector to 16-pin DIP connector
11713B-701/11713C-701		Viking connector to 14-pin DIP connector
11713B-801/11713C-801		Viking connector to (4) 10-pin DIP connectors
11713B-908/11713C-908		Rack mount kit for one instrument
11713B-909/11713C-909		Rack mount kit for two instruments

Five Simple Steps to Configure your Switching System

1. Determine the switching device's model and option (DC connector).

Example

Model: **87104A (SP4T switch)**
 Option: **100 (solder terminal)**

2. Determine the attenuator/switch driver's model and option (interface cable).

Example

Model: **11713B**
 Option: **201 (Viking connector to 12-pin conductor cable, bare wire)**

3 Use the selection guide, Table A (page 11) for switches and Table B (page 12) for attenuators, to determine which configuration table to use for further reference.

Example

Selection guide: **Table A (for switches)**
 Configuration table: **Table F-1**

Table A: Selection guide for switches

Switch family	Switch model number	Switch option	11713B/C								
			Option 001	Option 101	Option 201	Option 301	Option 401	Option 501	Option 601	Option 701	Option 801
Bypass	8763A/B/C	No option			Table D-2						
	8764A/B/C	No option			Table D-3						
	N1811TL	202			Table O-3						
		201						Table O-4			
	N1812UL	202			Table O-1						
		201						Table O-2			
SPDT	8761A/B ¹	No option			Table C-1						
	8762A/B/C/F	No option			Table D-1						
	8765A/B/C/D/F	3xx			Table E-1						
		3xx				Table E-2					
	N1810UL	202			Table O-1						
		201						Table O-2			
	N1810TL	202			Table O-3						
		201						Table O-4			
SP3T	8766K	016	Table J-1								
		060		Table J-2							
SP4T	87104A/B/C/D	100			Table F-1						
		161						Table F-2			
	87204A/B/C	100			Table G-1						
		161						Table G-2			

4. Configure your switching system using Table F-1 (page 16) as a reference.

Table F-1: Configuration of 11713B/C (Option 201) to 87104A/B/C/D, L7104A/B/C & L7204A/B/C SP4T switches (Option 100)

From 11713B/C (Option 201)				To 87104A/B/C/D, L7104A/B/C & L7204A/B/C (Option 100)	
Front panel pushbutton		Interface cable		Solder terminal number	RF path
Attenuator X	LED	Viking connector pin number	Bare wire color		
–	–	1 (VCC)	Red	1	–
–	–	2 (GND)	White/Brown	15	–
1	OFF	5	Violet	5	2 to C closed
2	OFF	7	Black	7	3 to C closed
3	OFF	9	Orange	11	5 to C closed
4	OFF	11	Brown	13	6 to C closed

5. Operate your system.

Table A: Selection guide for switches

Switch family	Switch model number	Switch option	11713B/C								
			Option 001	Option 101	Option 201	Option 301	Option 401	Option 501	Option 601	Option 701	Option 801
Bypass	8763A, 8763B, 8763C	011/015/024			Table D-2						
		T15/T24			Table D-5						
	8764A, 8764B, 8764C	011/015/024			Table D-3						
		T15/T24			Table D-6						
	N1811TL ²	202/403			Table O-3						
		201/403						Table O-4			
		202/401/403			Table O-7						
	N1812UL ²	201/401/403						Table O-8			
		202/403			Table O-1						
		201/403						Table O-2			
202/401/403				Table O-5							
SPDT	8761A, 8761B ¹	No option			Table C-1						
		8762A, 8762B, 8762C, 8762F	011/015/024			Table D-1					
	8765A, 8765B, 8765C, 8765D, 8765F ³	T15/T24			Table D-4						
		305/310/315/324			Table E-1						
	N1810UL ²	005/010/015/024				Table E-2					
		202/403			Table O-1						
		201/403						Table O-2			
		202/401/403			Table O-5						
	N1810TL ²	201/401/403						Table O-6			
		202/403			Table O-3						
201/403							Table O-4				
202/401/403				Table O-7							
SP3T	8766K	016	Table J-1								
		060		Table J-2							
SP4T	87104A, 87104B, 87104C, 87104D	100			Table F-1						
		161						Table F-2			
	87204A, 87204B, 87204C	100			Table G-1						
		161						Table G-2			
	L7104A, L7104B, L7104C	100			Table F-1						
		161						Table F-2			
	L7204A, L7204B, L7204C	100			Table F-1						
		161						Table F-2			
8767K	016	Table J-1									
	060		Table J-2								
8767M	No option	Table L									
SP5T	8768K	016	Table J-1								
		060		Table J-2							
	8768M	No option	Table L								
SP6T	87106A, 87106B, 87106C, 87106D	100			Table H-1						
		161					Table H-2				
	87206A, 87206B, 87206C	100			Table I-1						
		161					Table I-2				
	L7106A, L7106B, L7106C	100			Table H-1						
		161					Table H-2				
	L7206A, L7206B, L7206C	100			Table H-1						
		161					Table H-2				
8769K	060		Table K								
8769M	No option							Table M			
Matrix	87406B	100			Table H-1						
		161					Table H-2				
	87606B	100			Table I-1						
		161					Table I-2				
Transfer	87222C, 87222D, 87222E	100			Table N-1						
		161							Table N-2		
	L7222C	100			Table N-1						
		161								Table N-2	

1. Refer to Table C-2 if a cable with banana jacks is used to make a connection between 8761A/B and 11713B/C.
2. N1810UL/TL, N1811TL and N1812UL cannot withstand continuous current. Option 403 (current interrupt) is required to protect the switches from damage due to overheating.
3. 8765A/B/C/D/F require continuous current to latch. The number of switches for connection depends on option selection.

Switch Option Descriptions

011:	5 Vdc
015:	15 Vdc
024:	24 Vdc
T15:	TTL/5V CMOS compatible logic with 15 Vdc supply
T24:	TTL/5V CMOS compatible logic with 24 Vdc supply
201:	D-submini 9 pin (f)
202:	Solder lug
401:	TTL/5V CMOS compatible
305:	5 Vdc with solder terminals
310:	10 Vdc with solder terminals
315:	15 Vdc with solder terminals
324:	24 Vdc with solder terminals
005:	5 Vdc with 3-inch ribbon cable
010:	10 Vdc with 3-inch ribbon cable
016:	16-inch ribbon cables
060:	Viking cable connector
100:	Solder terminals
161:	Ribbon receptacle

Table B: Selection guide for attenuators

Attenuator model number	Attenuator option	11713B/C	
		Option 001	Option 101
8494G, 8494H	016	Table P-1	
	060		Table P-2
8495G, 8495H	016	Table P-1	
	060		Table P-2
8496G, 8496H	016	Table P-1	
	060		Table P-2
8495K	016	Table P-1	
	060		Table P-2
8497K	016	Table P-1	
	060		Table P-2
84904K, 84904L, 84904M	No option	Table Q	
84905M	No option	Table Q	
84906K, 84906L	No option	Table Q	
84907K, 84907L	No option	Table Q	
84908M	No option	Table Q	

Attenuator Option Description

Option 060: 12-pin Viking connector
 Option 016: 16-inch ribbon cable with 14-pin DIP plug

Configuration Information for Switches

Note 1: Each table below illustrates the configuration of two switches to the 11713B/C.

Note 2: For 8761A, V = 15V.

Note 3: For 8761B, V = 24V.

Note 4: 2,000,000 switching cycles at 0.7 A for contact pairs 9 and 0. For more details, please refer to the "Supplemental characteristics" table on page 3.

Table C-1: Configuration of 11713B/C (Option 201) to 8761A/B SPDT switches

From 11713B/C (Option 201)				To 8761A/B		
Front panel pushbutton		Interface cable				
Switches	LED	Viking connector pin number	Bare wire color	Solder terminal number	RF path	Device under test (DUT)
9	OFF	Cable 1-3	Gray	<+>	2 to C closed	DUT 1
		Cable 1-4	White/Red	<->		
	ON	Cable 1-3	Gray	<+>	1 to C closed	
		Cable 1-4	White/Red	<->		
0	OFF	Cable 2-3	Gray	<+>	2 to C closed	DUT 2
		Cable 2-4	White/Red	<->		
	ON	Cable 2-3	Gray	<+>	1 to C closed	
		Cable 2-4	White/Red	<->		

Table C-2: Configuration of 11713B/C (any option) to 8761A/B SPDT switches

From 11713B/C (any option)				To 8761A/B		
Front panel pushbutton		Banana jack (rear panel)				
Switches	LED	Pin number	Voltage	Solder terminal number	RF path	Device under test (DUT)
9	OFF	S9-A	+V	<+>	2 to C closed	DUT 1
		S9-B	0	<->		
	ON	S9-A	0	<+>	1 to C closed	
		S9-B	+V	<->		
0	OFF	S0-A	+V	<+>	2 to C closed	DUT 2
		S0-B	0	<->		
	ON	S0-A	0	<+>	1 to C closed	
		S0-B	+V	<->		

Note 1: Each table below illustrates the configuration of five switches to the 11713B/C.

Note 2: Five additional switches can be driven by Attenuator Y (front panel pushbuttons 5, 6, 7, 8 & 0) using the same configuration as Attenuator X.

Note 3: 2,000,000 switching cycles at 0.7 A for contact pairs 9 and 0. For more details, please refer to the “Supplemental characteristics” table on page 3.

Table D-1: Configuration of 11713B/C (Option 201) to 8762A/B/C/F SPDT switches (Option 005/011/024)

From 11713B/C (Option 201)				To 8762A/B/C/F (Option 005/011/024)		
Front panel pushbutton		Interface cable		Solder terminal number	RF path	Device under test (DUT)
Attenuator X	LED	Viking connector pin number	Bare wire color			
–	–	1 (VCC)	Red	C	–	VCC for all 5 DUTs
1	OFF	5	Violet	1	1 to C closed, 2 terminated	DUT 1
	ON	6	Yellow	2	2 to C closed, 1 terminated	
2	OFF	7	Black	1	1 to C closed, 2 terminated	DUT 2
	ON	8	Green	2	2 to C closed, 1 terminated	
3	OFF	9	Orange	1	1 to C closed, 2 terminated	DUT 3
	ON	10	Blue	2	2 to C closed, 1 terminated	
4	OFF	11	Brown	1	1 to C closed, 2 terminated	DUT 4
	ON	12	White	2	2 to C closed, 1 terminated	
9	OFF	4	Gray	1	1 to C closed, 2 terminated	DUT 5
	ON	3	White/Red	2	2 to C closed, 1 terminated	

Table D-2: Configuration of 11713B/C (Option 201) to 8763A/B/C bypass switches (Option 005/011/024)

From 11713B/C (Option 201)				To 8763A/B/C (Option 005/011/024)		
Front panel pushbutton		Interface cable		Solder terminal number	RF path	Device under test (DUT)
Attenuator X	LED	Viking connector pin number	Bare wire color			
–	–	1 (VCC)	Red	C	–	VCC for all 5 DUTs
1	OFF	5	Violet	1	1 to 2 closed, 3 to 4 closed	DUT 1
	ON	6	Yellow	2	1 terminated, 2 to 3 closed, 4 open	
2	OFF	7	Black	1	1 to 2 closed, 3 to 4 closed	DUT 2
	ON	8	Green	2	1 terminated, 2 to 3 closed, 4 open	
3	OFF	9	Orange	1	1 to 2 closed, 3 to 4 closed	DUT 3
	ON	10	Blue	2	1 terminated, 2 to 3 closed, 4 open	
4	OFF	11	Brown	1	1 to 2 closed, 3 to 4 closed	DUT 4
	ON	12	White	2	1 terminated, 2 to 3 closed, 4 open	
9	OFF	4	Gray	1	1 to 2 closed, 3 to 4 closed	DUT 5
	ON	3	White/Red	2	1 terminated, 2 to 3 closed, 4 open	

Table D-3: Configuration of 11713B/C (Option 201) to 8764A/B/C bypass switches (Option 005/011/024)

From 11713B/C (Option 201)				To 8764A/B/C (Option 005/011/024)		
Front panel pushbutton		Interface cable		Solder terminal number	RF path	Device under test (DUT)
Attenuator X	LED	Viking connector pin number	Bare wire color			
–	–	1 (VCC)	Red	C	–	VCC for all 5 DUTs
1	OFF	5	Violet	1	1 open, 2 to 3 closed, 4 to 5 closed	DUT 1
	ON	6	Yellow	2	1 to 2 closed, 3 to 4 closed, 5 open	
2	OFF	7	Black	1	1 open, 2 to 3 closed, 4 to 5 closed	DUT 2
	ON	8	Green	2	1 to 2 closed, 3 to 4 closed, 5 open	
3	OFF	9	Orange	1	1 open, 2 to 3 closed, 4 to 5 closed	DUT 3
	ON	10	Blue	2	1 to 2 closed, 3 to 4 closed, 5 open	
4	OFF	11	Brown	1	1 open, 2 to 3 closed, 4 to 5 closed	DUT 4
	ON	12	White	2	1 to 2 closed, 3 to 4 closed, 5 open	
9	OFF	4	Gray	1	1 open, 2 to 3 closed, 4 to 5 closed	DUT 5
	ON	3	White/Red	2	1 to 2 closed, 3 to 4 closed, 5 open	

Note 1: Each table below illustrates the configuration of five switches to the 11713B/C.

Note 2: Five additional switches can be driven by Attenuator Y (front panel pushbuttons 5, 6, 7, 8 & 0) using the same configuration as Attenuator X.

Note 3: 2,000,000 switching cycles at 0.7 A for contact pairs 9 and 0. For more details, please refer to the "Supplemental characteristics" table on page 3.

Table D-4: Configuration of 11713B/C (Option 201) to 8762A/B/C/F SPDT switches (Option T15/T24)

From 11713B/C (Option 201)				To 8762A/B/C/F (Option T15/T24)		
Front Panel Pushbutton		Interface Cable		Solder Terminal Number	RF Path	Device Under Test (DUT)
Attenuator X	LED	Viking Connector Pin Number	Bare Wire Color			
–	–	1 (VCC)	Red	C	–	VCC for all 5 DUTs
–	–	2 (GND)	White/Brown	2	–	GND for all 5 DUTs
1	OFF	5	Violet	1	1 to C closed, 2 terminated	DUT 1
	ON				2 to C closed, 1 terminated	
2	OFF	7	Black	1	1 to C closed, 2 terminated	DUT 2
	ON				2 to C closed, 1 terminated	
3	OFF	9	Orange	1	1 to C closed, 2 terminated	DUT 3
	ON				2 to C closed, 1 terminated	
4	OFF	11	Brown	1	1 to C closed, 2 terminated	DUT 4
	ON				2 to C closed, 1 terminated	
9	OFF	4	Gray	1	1 to C closed, 2 terminated	DUT 5
	ON				2 to C closed, 1 terminated	

Table D-5: Configuration of 11713B/C (Option 201) to 8763A/B/C bypass switches (Option T15/T24)

From 11713B/C (Option 201)				To 8763A/B/C (Option T15/T24)		
Front Panel Pushbutton		Interface Cable		Solder Terminal Number	RF Path	Device Under Test (DUT)
Attenuator X	LED	Viking Connector Pin Number	Bare Wire Color			
–	–	1 (VCC)	Red	C	–	VCC for all 5 DUTs
–	–	2 (GND)	White/Brown	2	–	GND for all 5 DUTs
1	OFF	5	Violet	1	1 to 2 closed, 3 to 4 closed	DUT 1
	ON				1 terminated, 2 to 3 closed, 4 open	
2	OFF	7	Black	1	1 to 2 closed, 3 to 4 closed	DUT 2
	ON				1 terminated, 2 to 3 closed, 4 open	
3	OFF	9	Orange	1	1 to 2 closed, 3 to 4 closed	DUT 3
	ON				1 terminated, 2 to 3 closed, 4 open	
4	OFF	11	Brown	1	1 to 2 closed, 3 to 4 closed	DUT 4
	ON				1 terminated, 2 to 3 closed, 4 open	
9	OFF	4	Gray	1	1 to 2 closed, 3 to 4 closed	DUT 5
	ON				1 terminated, 2 to 3 closed, 4 open	

Table D-6: Configuration of 11713B/C (Option 201) to 8764A/B/C bypass switches (Option T15/T24)

From 11713B/C (Option 201)				To 8764A/B/C (Option T15/T24)		
Front Panel Pushbutton		Interface Cable		Solder Terminal Number	RF Path	Device Under Test (DUT)
Attenuator X	LED	Viking Connector Pin Number	Bare Wire Color			
–	–	1 (VCC)	Red	C	–	VCC for all 5 DUTs
–	–	2 (GND)	White/Brown	2	–	GND for all 5 DUTs
1	OFF	5	Violet	1	1 open, 2 to 3 closed, 4 to 5 closed	DUT 1
	ON				1 to 2 closed, 3 to 4 closed, 5 open	
2	OFF	7	Black	1	1 open, 2 to 3 closed, 4 to 5 closed	DUT 2
	ON				1 to 2 closed, 3 to 4 closed, 5 open	
3	OFF	9	Orange	1	1 open, 2 to 3 closed, 4 to 5 closed	DUT 3
	ON				1 to 2 closed, 3 to 4 closed, 5 open	
4	OFF	11	Brown	1	1 open, 2 to 3 closed, 4 to 5 closed	DUT 4
	ON				1 to 2 closed, 3 to 4 closed, 5 open	
9	OFF	4	Gray	1	1 open, 2 to 3 closed, 4 to 5 closed	DUT 5
	ON				1 to 2 closed, 3 to 4 closed, 5 open	

Note 1: Each table below illustrates the configuration of five switches to the 11713B/C.

Note 2: Requires continuous current to latch. The number of switches available for connection depends on option selection.

Note 3: Five switches can be driven by Attenuator Y (front panel pushbuttons 5, 6, 7, 8 & 0) using the same configuration as Attenuator X.

Note 4: 2,000,000 switching cycles at 0.7 A for contact pairs 9 and 0. For more details, please refer to the “Supplemental characteristics” table on page

**Table E-1: Configuration of 11713B/C (Option 201)
to 8765A/B/C/D/F SPDT switches (Options 3xx)**

From 11713B/C (Option 201)				To 8765A/B/C/D/F (Option 305/310/315/324)		
Front Panel Pushbutton		Interface Cable				
Attenuator X	LED	Viking connector pin number	Bare wire color	Solder terminal number	RF path	Device under test (DUT)
-	-	1 (VCC)	Red	2 and 3	-	VCC for all 5 DUTs
1	OFF	5	Violet	1	2 to C closed, 1 open	DUT 1
	ON	6	Yellow	4	1 to C closed, 2 open	
2	OFF	7	Black	1	2 to C closed, 1 open	DUT 2
	ON	8	Green	4	1 to C closed, 2 open	
3	OFF	9	Orange	1	2 to C closed, 1 open	DUT 3
	ON	10	Blue	4	1 to C closed, 2 open	
4	OFF	11	Brown	1	2 to C closed, 1 open	DUT 4
	ON	12	White	4	1 to C closed, 2 open	
9	OFF	4	Gray	1	2 to C closed, 1 open	DUT 5
	ON	3	White/Red	4	1 to C closed, 2 open	

**Table E-2: Configuration of 11713B/C (Option 301)
to 8765A/B/C/D/F SPDT switches (Options 0xx)**

From 11713B/C (Option 301)				To 8765A/B/C/D/F (Option 005/010/015/024)		
Front panel pushbutton		Interface cable				
Attenuator X	LED	Viking connector pin number/ banana jack (rear panel)	5-pin receptacle pin number	Ribbon cable connector pin number	RF path	Device under test (DUT)
-	-	1 (VCC)/VDC COM	3 and 4	3 and 4	-	VCC for all 5 DUTs
1	OFF	5	1	1	2 to C closed, 1 open	DUT 1
	ON	6	5	5	1 to C closed, 2 open	
2	OFF	7	1	1	2 to C closed, 1 open	DUT 2
	ON	8	5	5	1 to C closed, 2 open	
3	OFF	9	1	1	2 to C closed, 1 open	DUT 3
	ON	10	5	5	1 to C closed, 2 open	
4	OFF	11	1	1	2 to C closed, 1 open	DUT 4
	ON	12	5	5	1 to C closed, 2 open	
9	OFF	S9-A	—	1	2 to C closed, 1 open	DUT 5
	ON	S9-B	—	5	1 to C closed, 2 open	

Note 1: Each table below illustrates the configuration of one switch to the 11713B/C.

Note 2: For switches with Option 161, ground pin 16 opens all paths. Use S9 for Attenuator X or S0 for Attenuator Y.*

* Do not close any path and ground pin 16 simultaneously as this makes the switch buzz.

Note 3: For switches with Option 100, there are no solder terminals available to open all paths.

Note 4: Solder terminal/DIP connector with pin numbers 6, 8, 12 & 14 provides indicator function.

Note 5: Applies to both Option 024 (standard/non-TTL drive) and Option T24 (TTL drive).

Note 6: One additional switch can be driven by Attenuator Y (front panel pushbuttons 5, 6, 7 & 8) using the same configuration as Attenuator X.

**Table F-1: Configuration of 11713B/C (Option 201)
to 87104A/B/C/D, L7104A/B/C & L7204A/B/C SP4T switches (Option 100)**

From 11713B/C (Option 201)				To 87104A/B/C/D, L7104A/B/C & L7204A/B/C (Option 100)	
Front panel pushbutton		Interface cable			
Attenuator X	LED	Viking connector pin number	Bare wire color	Solder terminal number	RF path
–	–	1 (VCC)	Red	1	–
–	–	2 (GND)	White/Brown	15	–
1	OFF	5	Violet	5	2 to C closed
2	OFF	7	Black	7	3 to C closed
3	OFF	9	Orange	11	5 to C closed
4	OFF	11	Brown	13	6 to C closed

**Table F-2: Configuration of 11713B/C (Option 601)
to 87104A/B/C/D, L7104A/B/C & L7204A/B/C SP4T switches (Option 161)**

From 11713B/C (Option 601)				To 87104A/B/C/D, L7104A/B/C & L7204A/B/C (Option 161)	
Front panel pushbutton		Interface cable			
Attenuator X	LED	Viking connector pin number	16-pin DIP pin number	RF path	
–	–	1 (VCC)	1	–	
–	–	2 (GND)	15	–	
1	OFF	5	5	2 to C closed	
2	OFF	7	7	3 to C closed	
3	OFF	9	11	5 to C closed	
4	OFF	11	13	6 to C closed	

Note 1: Each table below illustrates the configuration of one switch to the 11713B/C.

Note 2: For switches with Option 161, ground pin 16 opens all paths. Use S9 for Attenuator X or S0 for Attenuator Y.*

* Do not close any path and ground pin 16 simultaneously as this makes the switch to buzz.

Note 3: For switch with Option 100, no solder terminal available to open all paths.

Note 4: Applies to both Option 024 (standard/non-TTL drive) and Option T24 (TTL drive).

Note 5: One additional switch can be driven by Attenuator Y (front panel pushbuttons 5, 6, 7 & 8) using the same configuration as Attenuator X.

Table G-1: Configuration of 11713B/C (Option 201) to 87204A/B/C SP4T switches (Option 100)

From 11713B/C (Option 201)				To 87204A/B/C (Option 100)	
Front panel pushbutton		Interface cable			
Attenuator X	LED	Viking connector pin number	Bare wire color	Solder terminal number	RF path
–	–	1 (VCC)	Red	1	–
–	–	2 (GND)	White/Brown	15	–
1	OFF	5	Violet	5	2 to C closed
	ON	6	Yellow	6	2 to C opened
2	OFF	7	Black	7	3 to C closed
	ON	8	Green	8	3 to C opened
3	OFF	9	Orange	11	5 to C closed
	ON	10	Blue	12	5 to C opened
4	OFF	11	Brown	13	6 to C closed
	ON	12	White	14	6 to C opened

Table G-2: Configuration of 11713B/C (Option 601) to 87204A/B/C SP4T switches (Option 161)

From 11713B/C (Option 601)				To 87204A/B/C (Option 161)	
Front panel pushbutton		Interface cable			
Attenuator X	LED	Viking connector pin number	16-pin DIP pin number	RF path	
–	–	1 (VCC)	1	–	
–	–	2 (GND)	15	–	
1	OFF	5	5	2 to C closed	
	ON	6	6	2 to C opened	
2	OFF	7	7	3 to C closed	
	ON	8	8	3 to C opened	
3	OFF	9	11	5 to C closed	
	ON	10	12	5 to C opened	
4	OFF	11	13	6 to C closed	
	ON	12	14	6 to C opened	

Note 1: Each table below illustrates the configuration of one switch to the 11713B/C.

Note 2: For switches with Option 161, ground pin 16 opens all paths. Use S9 for Attenuator X or S0 for Attenuator Y.*

* Do not close any path and ground pin 16 simultaneously as this makes the switch to buzz.

Note 3: For switch with Option 100, no solder terminal available to open all paths.

Note 4: Solder terminal/DIP connector with pin numbers 4, 6, 8, 10, 12 & 14 provides indicator function.

Note 5: Applies to both Option 024 (standard/non-TTL drive) and Option T24 (TTL drive).

Table H-1: Configuration of 11713B/C (Option 201) to 87106A/B/C/D, L7106A/B/C & L7206A/B/C SP6T switches (Option 100) and 87406B matrix switch (Option 100)

From 11713B/C (Option 201 - quantity 2)				To 87106A/B/C/D, L7106A/B/C, L7206A/B/C and 87406B (Option 100)	
Front panel pushbutton		Interface cable		Solder terminal number	RF path
Attenuator X/Y	LED	Viking connector pin number	Bare wire color		
–	–	1 (VCC)	Red	1	–
–	–	2 (GND)	White/Brown	15	–
1	OFF	Cable 1-5	Violet	3	1 to C closed
2	OFF	Cable 1-7	Black	5	2 to C closed
3	OFF	Cable 1-9	Orange	7	3 to C closed
4	OFF	Cable 1-11	Brown	9	4 to C closed
5	OFF	Cable 2-5	Violet	11	5 to C closed
6	OFF	Cable 2-7	Black	13	6 to C closed

Table H-2: Configuration of 11713B/C (Option 401) to 87106A/B/C/D, L7106A/B/C & L7206A/B/C SP6T switches (Option 161) and 87406B matrix switch (Option 161)

From 11713B/C (Option 401)				To 87106A/B/C/D, L7106A/B/C, L7206A/B/C and 87406B (Option 161)	
Front panel pushbutton		Interface cable		RF path	
Attenuator X/Y	LED	Viking connector pin number	16-pin DIP pin number		
–	–	1 (VCC)	1	–	
–	–	2 (GND)	15	–	
1	OFF	P1-5	3	1 to C closed	
2	OFF	P1-7	5	2 to C closed	
3	OFF	P1-9	7	3 to C closed	
4	OFF	P1-11	9	4 to C closed	
5	OFF	P2-5	11	5 to C closed	
6	OFF	P2-7	13	6 to C closed	

Note 1: Each table below illustrates the configuration of one switch to the 11713B/C.

Note 2: For switches with Option 161, ground pin 16 opens all paths. Use S9 for Attenuator X or S0 for Attenuator Y.*

* Do not close any path and ground pin 16 simultaneously as this makes the switch to buzz.

Note 3: For switch with Option 100, no solder terminal available to open all paths.

Note 4: Applies to both Option 024 (standard/non-TTL drive) and Option T24 (TTL drive).

Table I-1: Configuration of 11713B/C (Option 201) to 87206A/B/C SP6T switches (Option 100) & 87606B matrix switch (Option 100)

From 11713B/C (Option 201 - quantity 2)				To 87206A/B/C & 87606B (Option 100)	
Front panel pushbutton		Interface cable			
Attenuator X/Y	LED	Viking connector pin number	Bare wire color	Solder terminal number	RF path
–	–	1 (VCC)	Red	1	–
–	–	2 (GND)	White/Brown	15	–
1	OFF	Cable 1-5	Violet	3	1 to C closed
	ON	Cable 1-6	Yellow	4	1 to C opened
2	OFF	Cable 1-7	Black	5	2 to C closed
	ON	Cable 1-8	Green	6	2 to C opened
3	OFF	Cable 1-9	Orange	7	3 to C closed
	ON	Cable 1-10	Blue	8	3 to C opened
4	OFF	Cable 1-11	Brown	9	4 to C closed
	ON	Cable 1-12	White	10	5 to C opened
5	OFF	Cable 2-5	Violet	11	5 to C closed
	ON	Cable 2-6	Yellow	12	5 to C opened
6	OFF	Cable 2-7	Black	13	6 to C closed
	ON	Cable 2-8	Green	14	6 to C opened

Table I-2: Configuration of 11713B/C (Option 401) to 87206A/B/C SP6T switches (Option 161) & 87606B matrix switch (Option 161)

From 11713B/C (Option 401)				To 87206A/B/C & 87606B (Option 161)	
Front panel pushbutton		Interface cable			
Attenuator X/Y	LED	Viking connector pin number	16-pin DIP pin number	RF path	
–	–	1 (VCC)	1	–	
–	–	2 (GND)	15	–	
1	OFF	P1-5	3	1 to C closed	
	ON	P1-6	4	1 to C opened	
2	OFF	P1-7	5	2 to C closed	
	ON	P1-8	6	2 to C opened	
3	OFF	P1-9	7	3 to C closed	
	ON	P1-10	8	3 to C opened	
4	OFF	P1-11	9	4 to C closed	
	ON	P1-12	10	4 to C opened	
5	OFF	P2-5	11	5 to C closed	
	ON	P2-6	12	5 to C opened	
6	OFF	P2-7	13	6 to C closed	
	ON	P2-8	14	6 to C opened	

Note 1: Each table below illustrates the configuration of one switch to the 11713B/C.

Note 2: With assumption that the initial state of switch's RF path is thru.

Note 3: One additional switch can be driven by Attenuator Y (front panel pushbuttons 5, 6, 7 & 8) using the same configuration as Attenuator X.

Table J-1: Configuration of 11713B/C (Option 001) to 8766K, 8767K & 8768K switches (Option 016)

From 11713B/C (Option 001)				To 8766K, 8767K & 8768K (Option 016)		
Front panel pushbutton		Interface cable		8766K	8767K	8768K
Attenuator X	LED	Viking connector pin number	10-pin DIP pin number	RF path	RF path	RF path
–	–	1 (VCC)	10	–	–	–
1	OFF	5	1	Bypass 1	Bypass 3	Bypass 4
	ON	6	2	1 to C closed	3 to C closed	4 to C closed
2	OFF	7	5	Bypass 2	Bypass 1	Bypass 2
	ON	8	8	2 to C closed	1 to C closed	2 to C closed
3	OFF	9	4	–	Bypass 2	Bypass 3
	ON	10	9	–	2 to C closed	3 to C closed
4	OFF	11	6	–	–	Bypass 1
	ON	12	7	–	–	1 to C closed

Table J-2: Configuration of 11713B/C (Option 101) to 8766K, 8767K & 8768K switches (Option 060)

From 11713B/C (Option 101)				To 8766K, 8767K & 8768K (Option 060)		
Front panel pushbutton		Interface cable		8766K	8767K	8768K
Attenuator X	LED	Viking connector pin number	Viking connector pin number	RF path	RF path	RF path
–	–	1 (VCC)	1	–	–	–
1	OFF	5	5	Bypass 1	Bypass 3	Bypass 4
	ON	6	6	1 to C closed	3 to C closed	4 to C closed
2	OFF	7	7	Bypass 2	Bypass 1	Bypass 2
	ON	8	8	2 to C closed	1 to C closed	2 to C closed
3	OFF	9	9	–	Bypass 2	Bypass 3
	ON	10	10	–	2 to C closed	3 to C closed
4	OFF	11	11	–	–	Bypass 1
	ON	12	12	–	–	1 to C closed

Note 1: Each table below illustrates the configuration of one switch to the 11713B/C.

Note 2: With assumption that initial state of switch's RF path is thru.

Note 3: One additional switch can be driven by Attenuator Y (front panel pushbuttons 5, 6, 7 & 8) using the same configuration as Attenuator X. Use S0 for Attenuator Y and S9 for Attenuator X.

Table K: Configuration of 11713B/C (Option 101) to 8769K SP6T switch (Option 060)

From 11713B/C (Option 101)				To 8769K (Option 060)
Front panel pushbutton		Interface cable		
Attenuator X	LED	Viking connector pin number	Viking connector pin number	RF path
–	–	1 (VCC)	1	–
S9	OFF	4	4	Bypass 5
	ON	3	3	5 to C closed
1	OFF	5	5	Bypass 4
	ON	6	6	4 to C closed
2	OFF	7	7	Bypass 2
	ON	8	8	2 to C closed
3	OFF	9	9	Bypass 3
	ON	10	10	3 to C closed
4	OFF	11	11	Bypass 1
	ON	12	12	1 to C closed

Table L: Configuration of 11713B/C (Option 001) to 8767M & 8768M switches

From 11713B/C (Option 001)				To 8767M and 8768M	
Front panel pushbutton		Interface cable		RF path	RF path
Attenuator X	LED	Viking connector pin number	10-pin DIP pin number	RF path	RF path
–	–	1 (VCC)	10	–	–
1	OFF	5	1	Bypass 3	Bypass 4
	ON	6	2	3 to C closed	4 to C closed
2	OFF	7	5	Bypass 1	Bypass 2
	ON	8	8	1 to C closed	2 to C closed
3	OFF	9	4	Bypass 2	Bypass 3
	ON	10	9	2 to C closed	3 to C closed
4	OFF	11	6	–	Bypass 1
	ON	12	7	–	1 to C closed

Table M: Configuration of 11713B/C (Option 701) to 8769M SP6T switches

From 11713B/C (Option 701)				To 8769M
Front panel pushbutton		Interface cable		
Attenuator X	LED	Viking connector pin number	14-pin DIP pin number	RF path
–	–	1 (VCC)	12	–
S9	OFF	4	14	Bypass 5
	ON	3	13	5 to C closed
1	OFF	5	3	Bypass 4
	ON	6	4	4 to C closed
2	OFF	7	7	Bypass 2
	ON	8	10	2 to C closed
3	OFF	9	6	Bypass 3
	ON	10	11	3 to C closed
4	OFF	11	8	Bypass 1
	ON	12	9	1 to C closed

Note 1: Each table below illustrates the configuration of five switches to the 11713B/C.

Note 2: For standard/non-TTL drive only.

Note 3: Four additional switches can be driven by Attenuator Y (front panel pushbuttons 5, 6, 7 & 8) using the same configuration as Attenuator X. Use S0 for Attenuator Y and S9 for Attenuator X.

**Table N-1: Configuration of 11713B/C (Option 201)
to L7222C & 87222C/D/E DPDT switches (Option 100)**

From 11713B/C (Option 201)				To L7222C & 87222C/D/E (Option 100)		
Front panel pushbutton		Interface cable				
Attenuator X	LED	Viking connector pin number	Bare wire color	Solder terminal number	RF path	Device under test (DUT)
–	–	1 (VCC)	Red	1	–	VCC for all 4 DUTs
–	–	2 (GND)	White/Brown	9	–	GND for all 4 DUTs
1	OFF	5	Violet	3	1 to 2 closed, 3 to 4 closed	DUT 1
	ON	6	Yellow	5	1 to 4 closed, 2 to 3 closed	
2	OFF	7	Black	3	1 to 2 closed, 3 to 4 closed	DUT 2
	ON	8	Green	5	1 to 4 closed, 2 to 3 closed	
3	OFF	9	Orange	3	1 to 2 closed, 3 to 4 closed	DUT 3
	ON	10	Blue	5	1 to 4 closed, 2 to 3 closed	
4	OFF	11	Brown	3	1 to 2 closed, 3 to 4 closed	DUT 4
	ON	12	White	5	1 to 4 closed, 2 to 3 closed	

**Table N-2: Configuration of 11713B/C (Option 801)
to L7222C & 87222C/D/E DPDT switches (Option 161)**

From 11713B/C (Option 801)				To L7222C & 87222C/D/E (Option 161)	
Front panel pushbutton		Interface cable			
Attenuator X	LED	Viking connector pin number	10-pin DIP pin number	RF path	Device under test (DUT)
–	–	1 (VCC)	1	–	VCC for all 4 DUTs
–	–	2 (GND)	9	–	GND for all 4 DUTs
1	OFF	5	3	1 to 2 closed, 3 to 4 closed	DUT 1
	ON	6	5	1 to 4 closed, 2 to 3 closed	
2	OFF	7	3	1 to 2 closed, 3 to 4 closed	DUT 2
	ON	8	5	1 to 4 closed, 2 to 3 closed	
3	OFF	9	3	1 to 2 closed, 3 to 4 closed	DUT 3
	ON	10	5	1 to 4 closed, 2 to 3 closed	
4	OFF	11	3	1 to 2 closed, 3 to 4 closed	DUT 4
	ON	12	5	1 to 4 closed, 2 to 3 closed	

Note 1: Each table below illustrates the configuration of five switches to the 11713B/C.

Note 2: For standard/non-TTL drive only.

Note 3: Option 403 (current interrupt) is required to ensure switch is not damaged by overheating.

Note 4: Five additional switches can be driven by Attenuator Y (front panel pushbuttons 5, 6, 7, 8 & 0) using the same configuration as Attenuator X.

Note 5: 2,000,000 switching cycles at 0.7 A for contact pairs 9 and 0. For more details, please refer to the "Supplemental characteristics" table on page 3.

Table O-1: Configuration of 11713B/C (Option 201) to N1810UL SPDT switch (Option 202/403)

From 11713B/C (Option 201)				To N1810UL (Option 202)		
Front panel pushbutton		Interface cable				
Attenuator X	LED	Viking connector pin number	Bare wire color	Solder terminal number	RF path	Device under test (DUT)
–	–	1 (VCC)	Red	+V	–	VCC for all 5 DUTs
–	–	2 (GND)	White/Brown	GND	–	GND for all 5 DUTs
1	OFF	5	Violet	A	1 to C closed, 2 open	DUT 1
	ON	6	Yellow	B	2 to C closed, 1 open	
2	OFF	7	Black	A	1 to C closed, 2 open	DUT 2
	ON	8	Green	B	2 to C closed, 1 open	
3	OFF	9	Orange	A	1 to C closed, 2 open	DUT 3
	ON	10	Blue	B	2 to C closed, 1 open	
4	OFF	11	Brown	A	1 to C closed, 2 open	DUT 4
	ON	12	White	B	2 to C closed, 1 open	
9	OFF	4	Gray	A	1 to C closed, 2 open	DUT 5
	ON	3	White/Red	B	2 to C closed, 1 open	

Table O-2: Configuration of 11713B/C (Option 501) to N1810UL SPDT switch (Option 201/403)

From 11713B/C (Option 501)				To N1810UL (Option 201)	
Front panel pushbutton		Interface cable			
Attenuator X	LED	Viking connector pin number/banana jack (rear panel)	9-Pin Dsub pin number	RF path	Device under test (DUT)
–	–	1 (VCC)/VDC COM	5	–	VCC for all 5 DUTs
–	–	2 (GND)/GND	1	–	GND for all 5 DUTs
1	OFF	5	4	1 to C closed, 2 open	DUT 1
	ON	6	3	2 to C closed, 1 open	
2	OFF	7	4	1 to C closed, 2 open	DUT 2
	ON	8	3	2 to C closed, 1 open	
3	OFF	9	4	1 to C closed, 2 open	DUT 3
	ON	10	3	2 to C closed, 1 open	
4	OFF	11	4	1 to C closed, 2 open	DUT 4
	ON	12	3	2 to C closed, 1 open	
9	OFF	S9-A	4	1 to C closed, 2 open	DUT 5
	ON	S9-B	3	2 to C closed, 1 open	

Note 1: Each table below illustrates the configuration of five switches to the 11713B/C.

Note 2: For standard/non-TTL drive only.

Note 3: Option 403 (current interrupt) is required to ensure switch is not damaged by overheating.

Note 4: Five additional switches can be driven by Attenuator Y (front panel pushbuttons 5, 6, 7, 8 & 0) using the same configuration as Attenuator X.

Note 5: 2,000,000 switching cycles at 0.7 A for contact pairs 9 and 0. For more details, please refer to the "Supplemental characteristics" table on page 3.

Table O-3: Configuration of 11713B/C (Option 201) to N1810TL SPDT (Option 202/403)

From 11713A/B/C (Option 201)				To N1810TL (Option 202)		
Front panel pushbutton		Interface cable				
Attenuator X	LED	Viking connector pin number	Bare wire color	Solder terminal number	RF path	Device under test (DUT)
–	–	1 (VCC)	Red	+V	–	VCC for all 5 DUTs
–	–	2 (GND)	White/Brown	GND	–	GND for all 5 DUTs
1	OFF	5	Violet	A	1 to C closed, 2 terminated	DUT 1
	ON	6	Yellow	B	2 to C closed, 1 terminated	
2	OFF	7	Black	A	1 to C closed, 2 terminated	DUT 2
	ON	8	Green	B	2 to C closed, 1 terminated	
3	OFF	9	Orange	A	1 to C closed, 2 terminated	DUT 3
	ON	10	Blue	B	2 to C closed, 1 terminated	
4	OFF	11	Brown	A	1 to C closed, 2 terminated	DUT 4
	ON	12	White	B	2 to C closed, 1 terminated	
9	OFF	4	Gray	A	1 to C closed, 2 terminated	DUT 5
	ON	3	White/Red	B	2 to C closed, 2 terminated	

Table O-4: Configuration of 11713B/C (Option 501) to N1810TL SPDT switch (Option 201/403)

From 11713A/B/C (Option 501)				To N1810TL (Option 201)	
Front panel pushbutton		Interface cable			
Attenuator X	LED	Viking connector pin number/banana jack (rear panel)	9-pin Dsub pin number	RF path	Device under test (DUT)
–	–	1 (VCC)/VDC COM	5	–	VCC for all 5 DUTs
–	–	2 (GND)/GND	1	–	GND for all 5 DUTs
1	OFF	5	4	1 to C closed, 2 terminated	DUT 1
	ON	6	3	2 to C closed, 1 terminated	
2	OFF	7	4	1 to C closed, 2 terminated	DUT 2
	ON	8	3	2 to C closed, 1 terminated	
3	OFF	9	4	1 to C closed, 2 terminated	DUT 3
	ON	10	3	2 to C closed, 1 terminated	
4	OFF	11	4	1 to C closed, 2 terminated	DUT 4
	ON	12	3	2 to C closed, 1 terminated	
9	OFF	S9-A	4	1 to C closed, 2 terminated	DUT 5
	ON	S9-B	3	2 to C closed, 2 terminated	

Note 1: Each table below illustrates the configuration of three switches to the 11713B/C.

Note 2: For Option 401 (TTL drive) only.

Note 3: Option 403 (current interrupt) is required to ensure switch is not damaged by overheating.

Note 4: Two additional switches can be driven by Attenuator Y (front panel pushbuttons 5, 6, 7 & 8) using the same configuration as Attenuator X.

Note 5: 2,000,000 switching cycles at 0.7 A for contact pairs 9 and 0. For more details, please refer to the “Supplemental characteristics” table on page 3.

Table 0-5: Configuration of 11713B/C (Option 201) to N1810UL SPDT (Option 202/401/403)

From 11713B/C (Option 201)				To N1810UL (Option 202/401)		
Front panel pushbutton		Interface Cable				
Attenuator X	LED	Viking connector pin number	Bare wire color	Solder terminal number	RF path	Device under test (DUT)
–	–	1 (VCC)	Red	+V	–	VCC for all 3 DUTs
–	–	2 (GND)	White/Brown	GND	–	GND for all 3 DUTs
1	OFF	5	Violet	A	1 to C closed, 2 open	DUT1
2	ON	7	Black	B		
1	ON	5	Violet	A	2 to C closed, 1 open	
2	OFF	7	Black	B		
3	OFF	9	Orange	A	1 to C closed, 2 open	DUT2
4	ON	11	Brown	B		
3	ON	9	Orange	A	2 to C closed, 1 open	
4	OFF	11	Brown	B		
9	OFF	Cable 1-4	Gray	A	1 to C closed, 2 open	DUT 3
0	ON	Cable 1-3	White/Red	B		
9	ON	Cable 1-4	Gray	A	2 to C closed, 1 open	
0	OFF	Cable 1-3	White/Red	B		

Table 0-6: Configuration of 11713B/C (Option 501) to N1810UL SPDT switch (Option 201/401/403)

From 11713B/C (Option 501)				To N1810UL (Option 201/401)	
Front panel pushbutton		Interface Cable			
Attenuator X	LED	Viking connector pin number/ banana jack (rear panel)	9-pin Dsub pin number	RF path	Device under test (DUT)
–	–	1 (VCC)/VDC COM	5	–	VCC for all 3 DUTs
–	–	2 (GND)/GND	1	–	GND for all 3 DUTs
1	OFF	5	4	1 to C closed, 2 open	DUT1
2	ON	7	3		
1	ON	5	4	2 to C closed, 1 open	
2	OFF	7	3		
3	OFF	9	4	1 to C closed, 2 open	DUT2
4	ON	11	3		
3	ON	9	4	2 to C closed, 1 open	
4	OFF	11	3		
9	OFF	S9-A	4	1 to C closed, 2 open	DUT 3
0	ON	S9-B	3		
9	ON	S9-A	4	2 to C closed, 1 open	
0	OFF	S9-B	3		

Note 1: Each table below illustrates the configuration of three switches to the 11713B/C.

Note 2: For Option 401 (TTL drive) only.

Note 3: Option 403 (current interrupt) is required to ensure switch is not damaged by overheating.

Note 4: Two additional switches can be driven by Attenuator Y (front panel pushbuttons 5, 6, 7 & 8) using the same configuration as Attenuator X.

Note 5: 2,000,000 switching cycles at 0.7 A for contact pairs 9 and 0. For more details, please refer to the "Supplemental characteristics" table on page 3.

Table 0-7: Configuration of 11713B/C (Option 201) to N1810TL SPDT switch (Option 202/401/403)

From 11713A/B/C (Option 201)				To N1810TL (Option 202/401)		
Front panel pushbutton		Interface cable		Solder terminal number	RF path	Device under test (DUT)
Attenuator X	LED	Viking connector pin number	Bare wire color			
–	–	1 (VCC)	Red	+V	–	VCC for all 3 DUTs
–	–	2 (GND)	White/Brown	GND	–	GND for all 3 DUTs
1	OFF	5	Violet	A	1 to C closed, 2 terminated	DUT1
2	ON	7	Black	B		
1	ON	5	Violet	A	2 to C closed, 1 terminated	
2	OFF	7	Black	B		
3	OFF	9	Orange	A	1 to C closed, 2 terminated	DUT2
4	ON	11	Brown	B		
3	ON	9	Orange	A	2 to C closed, 1 terminated	
4	OFF	11	Brown	B		
9	OFF	Cable 1-4	Gray	A	1 to C closed, 2 terminated	DUT 3
0	ON	Cable 1-3	White/Red	B		
9	ON	Cable 1-4	Gray	A	2 to C closed, 1 terminated	
0	OFF	Cable 1-3	White/Red	B		

Table 0-8: Configuration of 11713B/C (Option 501) to N1810TL SPDT switch (Option 201/401/403)

From 11713A/B/C (Option 501)				To N1810TL (Option 201/401)	
Front Panel pushbutton		Interface cable		RF path	Device under test (DUT)
Attenuator X	LED	Viking connector pin number/ banana jack (rear panel)	9-pin Dsub pin number		
–	–	1 (VCC)/VDC COM	5	–	VCC for all 3 DUTs
–	–	2 (GND)/GND	1	–	GND for all 3 DUTs
1	OFF	5	4	1 to C closed, 2 terminated	DUT1
2	ON	7	3		
1	ON	5	4	2 to C closed, 1 terminated	
2	OFF	7	3		
3	OFF	9	4	1 to C closed, 2 terminated	DUT2
4	ON	11	3		
3	ON	9	4	2 to C closed, 1 terminated	
4	OFF	11	3		
9	OFF	S9-A	4	1 to C closed, 2 terminated	DUT 3
0	ON	S9-B	3		
9	ON	S9-A	4	2 to C closed, 1 terminated	
0	OFF	S9-B	3		

Note 1: Each table below illustrates configuration of five switches to 11713B/C.

Note 2: For standard/non TTL drive only.

Note 3: Option 403 (current interrupt) is required to ensure switch is not damaged by overheating.

Note 4: Five additional switches can be driven by Attenuator Y (front panel pushbuttons 5, 6, 7, 8 & 0) using the same configuration as Attenuator X.

Note 5: 2,000,000 switching cycles at 0.7 A for contact pairs 9 and 0. For more details, please refer to the "Supplemental characteristics" table on page 3.

Table O-9: Configuration of 11713B/C (Option 201) to N1812UL bypass switch (Option 202/403)

From 11713B/C (Option 201)				To N1812TL (Option 202)		
Front panel pushbutton		Interface cable				
Attenuator X	LED	Viking connector pin number	Bare wire color	Solder terminal number	RF path	Device under test (DUT)
–	–	1 (VCC)	Red	+V	–	VCC for all 5 DUTs
–	–	2 (GND)	White/Brown	GND	–	GND for all 5 DUTs
1	OFF	5	Violet	A	1 to open, 2 to 3, 4 to 5	DUT 1
	ON	6	Yellow	B	1 to 2, 3 to 4, 5 to open	
2	OFF	7	Black	A	1 to open, 2 to 3, 4 to 5	DUT 2
	ON	8	Green	B	1 to 2, 3 to 4, 5 to open	
3	OFF	9	Orange	A	1 to open, 2 to 3, 4 to 5	DUT 3
	ON	10	Blue	B	1 to 2, 3 to 4, 5 to open	
4	OFF	11	Brown	A	1 to open, 2 to 3, 4 to 5	DUT 4
	ON	12	White	B	1 to 2, 3 to 4, 5 to open	
9	OFF	4	Gray	A	1 to open, 2 to 3, 4 to 5	DUT 5
	ON	3	White/Red	B	1 to 2, 3 to 4, 5 to open	

Table O-10: Configuration of 11713B/C (Option 501) to N1812UL bypass switch (Option 201/403)

From 11713B/C (Option 501)				To N1812TL (Option 201)	
Front panel pushbutton		Interface cable			
Attenuator X	LED	Viking connector pin number/banana jack (rear panel)	9-pin Dsub pin number	RF path	Device under test (DUT)
–	–	1 (VCC)/VDC COM	5	–	VCC for all 5 DUTs
–	–	2 (GND)/GND	1	–	GND for all 5 DUTs
1	OFF	5	4	1 to open, 2 to 3, 4 to 5	DUT 1
	ON	6	3	1 to 2, 3 to 4, 5 to open	
2	OFF	7	4	1 to open, 2 to 3, 4 to 5	DUT 2
	ON	8	3	1 to 2, 3 to 4, 5 to open	
3	OFF	9	4	1 to open, 2 to 3, 4 to 5	DUT 3
	ON	10	3	1 to 2, 3 to 4, 5 to open	
4	OFF	11	4	1 to open, 2 to 3, 4 to 5	DUT 4
	ON	12	3	1 to 2, 3 to 4, 5 to open	
9	OFF	4	4	1 to open, 2 to 3, 4 to 5	DUT 5
	ON	3	3	1 to 2, 3 to 4, 5 to open	

Note 1: Each table below illustrates configuration of five switches to 11713B/C.

Note 2: For standard/non TTL drive only.

Note 3: Option 403 (current interrupt) is required to ensure switch is not damaged by overheating.

Note 4: Five additional switches can be driven by Attenuator Y (front panel pushbuttons 5, 6, 7, 8 & 0) using the same configuration as Attenuator X.

Note 5: 2,000,000 switching cycles at 0.7 A for contact pairs 9 and 0. For more details, please refer to the "Supplemental characteristics" table on page 3.

Table O-11: Configuration of 11713B/C (Option 201) to N1811TL bypass switch (Option 202/403)

From 11713B/C (Option 201)				To N1812UL (Option 202)		
Front panel pushbutton		Interface cable				
Attenuator X	LED	Viking connector pin number	Bare wire color	Solder terminal number	RF path	Device under test (DUT)
–	–	1 (VCC)	Red	+V	–	VCC for all 5 DUTs
–	–	2 (GND)	White/Brown	GND	–	GND for all 5 DUTs
1	OFF	5	Violet	A	1 to 2, 3 to 4	DUT 1
	ON	6	Yellow	B	1 terminated, 2 to 3, 4 to open	
2	OFF	7	Black	A	1 to 2, 3 to 4	DUT 2
	ON	8	Green	B	1 terminated, 2 to 3, 4 to open	
3	OFF	9	Orange	A	1 to 2, 3 to 4	DUT 3
	ON	10	Blue	B	1 terminated, 2 to 3, 4 to open	
4	OFF	11	Brown	A	1 to 2, 3 to 4	DUT 4
	ON	12	White	B	1 terminated, 2 to 3, 4 to open	
9	OFF	4	Gray	A	1 to 2, 3 to 4	DUT 5
	ON	3	White/Red	B	1 terminated, 2 to 3, 4 to open	

Table O-12: Configuration of 11713B/C (Option 501) to N1811TL bypass switch (Option 201/403)

From 11713B/C (Option 501)				To N1812UL (Option 201)	
Front Panel Pushbutton		Interface Cable			
Attenuator X	LED	Viking connector pin number/banana jack (rear panel)	9-pin Dsub pin number	RF path	Device under test (DUT)
–	–	1 (VCC)/VDC COM	5	–	VCC for all 5 DUTs
–	–	2 (GND)/GND	1	–	GND for all 5 DUTs
1	OFF	5	4	1 to 2, 3 to 4	DUT 1
	ON	6	3	1 terminated, 2 to 3, 4 to open	
2	OFF	7	4	1 to 2, 3 to 4	DUT 2
	ON	8	3	1 terminated, 2 to 3, 4 to open	
3	OFF	9	4	1 to 2, 3 to 4	DUT 3
	ON	10	3	1 terminated, 2 to 3, 4 to open	
4	OFF	11	4	1 to 2, 3 to 4	DUT 4
	ON	12	3	1 terminated, 2 to 3, 4 to open	
9	OFF	4	4	1 to 2, 3 to 4	DUT 5
	ON	3	3	1 terminated, 2 to 3, 4 to open	

Note 1: Each table below illustrates configuration of three switches to 11713B/C.

Note 2: For Option 401 (TTL drive) only.

Note 3: Option 403 (current interrupt) is required to ensure switch is not damaged by overheating.

Note 4: Two additional switches can be driven by Attenuator Y (front panel pushbuttons 5, 6, 7 & 8) using the same configuration as Attenuator X.

Note 5: 2,000,000 switching cycles at 0.7 A for contact pairs 9 and 0. For more details, please refer to the “Supplemental characteristics” table on page 3.

Table 0-13: Configuration of 11713B/C (Option 201) to N1812UL bypass switch (Option 202/401/403)

From 11713B/C (Option 201)				To N1812UL (Option 202)		
Front panel pushbutton		Interface cable				
Attenuator X	LED	Viking connector pin number	Bare wire color	Solder terminal number	RF path	Device under test (DUT)
–	–	1 (VCC)	Red	+V	–	VCC for all 3 DUTs
–	–	2 (GND)	White/Brown	GND	–	GND for all 3 DUTs
1	OFF	5	Violet	A	1 to open, 2 to 3, 4 to 5	DUT1
2	ON	7	Black	B		
1	ON	5	Violet	A	1 to 2, 3 to 4, 5 to open	
2	OFF	7	Black	B		
3	OFF	9	Orange	A	1 to open, 2 to 3, 4 to 5	DUT2
4	ON	11	Brown	B		
3	ON	9	Orange	A	1 to 2, 3 to 4, 5 to open	
4	OFF	11	Brown	B		
9	OFF	4	Gray	A	1 to open, 2 to 3, 4 to 5	DUT 3
0	ON	3	White/Red	B		
9	ON	4	Gray	A	1 to 2, 3 to 4, 5 to open	
0	OFF	3	White/Red	B		

Table 0-14: Configuration of 11713B/C (Option 501) to N1812UL bypass switch (Option 201/401/403)

From 11713B/C (Option 501)				To N1812UL (Option 201/401)	
Front panel pushbutton		Interface cable			
Attenuator X	LED	Viking connector pin number/ banana jack (rear panel)	9-pin Dsub pin number	RF path	Device under test (DUT)
–	–	1 (VCC)/VDC COM	5	–	VCC for all 3 DUTs
–	–	2 (GND)/GND	1	–	GND for all 3 DUTs
1	OFF	5	4	1 to open, 2 to 3, 4 to 5	DUT1
2	ON	7	3		
1	ON	5	4	1 to 2, 3 to 4, 5 to open	
2	OFF	7	3		
3	OFF	9	4	1 to open, 2 to 3, 4 to 5	DUT2
4	ON	11	3		
3	ON	9	4	1 to 2, 3 to 4, 5 to open	
4	OFF	11	3		
9	OFF	4	4	1 to open, 2 to 3, 4 to 5	DUT 3
0	ON	3	3		
9	ON	4	4	1 to 2, 3 to 4, 5 to open	
0	OFF	3	3		

Note 1: Each table below illustrates configuration of three switches to 11713B/C.

Note 2: For Option 401 (TTL drive) only.

Note 3: Option 403 (current interrupt) is required to ensure switch is not damaged by overheating.

Note 4: Two additional switches can be driven by Attenuator Y (front panel pushbuttons 5, 6, 7 & 8) using the same configuration as Attenuator X.

Note 5: 2,000,000 switching cycles at 0.7 A for contact pairs 9 and 0. For more details, please refer to the “Supplemental characteristics” table on page 3.

Table O-15: Configuration of 11713B/C (Option 201) to N1811TL bypass switch (Option 202/401/403)

From 11713B/C (Option 201)				To N1812UL (Option 202)		
Front panel pushbutton		Interface cable				
Attenuator X	LED	Viking connector pin number	Bare wire color	Solder terminal number	RF path	Device under test (DUT)
–	–	1 (VCC)	Red	+V	–	VCC for all 3 DUTs
–	–	2 (GND)	White/Brown	GND	–	GND for all 3 DUTs
1	OFF	5	Violet	A	1 to 2, 3 to 4	DUT1
2	ON	7	Black	B		
1	ON	5	Violet	A	1 terminated, 2 to 3, 4 to open	
2	OFF	7	Black	B		
3	OFF	9	Orange	A	1 to 2, 3 to 4	DUT2
4	ON	11	Brown	B		
3	ON	9	Orange	A	1 terminated, 2 to 3, 4 to open	
4	OFF	11	Brown	B		
9	OFF	4	Gray	A	1 to 2, 3 to 4	DUT 3
0	ON	3	White/Red	B		
9	ON	4	Gray	A	1 terminated, 2 to 3, 4 to open	
0	OFF	3	White/Red	B		

Table O-16: Configuration of 11713B/C (Option 501) to N1811TL bypass switch (Option 201/401/403)

From 11713B/C (Option 501)				To N1812UL (Option 201/401)	
Front panel pushbutton		Interface cable			
Attenuator X	LED	Viking connector pin number/ banana jack (rear panel)	9-pin Dsub pin number	RF path	Device under test (DUT)
–	–	1 (VCC)/VDC COM	5	–	VCC for all 3 DUTs
–	–	2 (GND)/GND	1	–	GND for all 3 DUTs
1	OFF	5	4	1 to 2, 3 to 4	DUT1
2	ON	7	3		
1	ON	5	4	1 terminated, 2 to 3, 4 to open	
2	OFF	7	3		
3	OFF	9	4	1 to 2, 3 to 4	DUT2
4	ON	11	3		
3	ON	9	4	1 terminated, 2 to 3, 4 to open	
4	OFF	11	3		
9	OFF	4	4	1 to 2, 3 to 4	DUT 3
0	ON	3	3		
9	ON	4	4	1 terminated, 2 to 3, 4 to open	
0	OFF	3	3		

Configuration Information for Attenuators

Note 1: Each table below illustrates the configuration of one attenuator to the 11713B/C.

Note 2: One additional attenuator can be driven by Attenuator Y (front panel pushbuttons 5, 6, 7 & 8) using the same configuration as Attenuator X.

Table P-1: Configuration of 11713B/C (Option 001) to 8494G/H, 8495G/H, 8496G/H, 8495K & 8497K programmable attenuators (Option 016)

From 11713B/C (Option 001)				To attenuators (Option 016)				
Front panel pushbutton		Interface cable		8494G/H	8495G/H	8496G/H	8495K	8497K
Attenuator X	LED	Viking connector pin number	10-pin DIP pin number	Attenuation (dB)				
–	–	1 (VCC)	10	–	–	–	–	–
1	OFF	5	1	0	0	0	0	0
	ON	6	2	1	10	10	10	10
2	OFF	7	5	0	0	0	0	0
	ON	8	8	2	20	20	20	20
3	OFF	9	4	0	0	0	0	0
	ON	10	9	4	40	40	20	30
4	OFF	11	6	0	–	0	0	0
	ON	12	7	4	–	40	20	30

Table P-2: Configuration of 11713B/C (Option 101) to 8494G/H, 8495G/H, 8496G/H, 8495K & 8497K programmable attenuators (Option 060)

From 11713B/C (Option 101)				To attenuators (Option 060)				
Front panel pushbutton		Interface cable		8494G/H	8495G/H	8496G/H	8495K	8497K
Attenuator X	LED	Viking connector pin number	Viking connector pin number	Attenuation (dB)				
–	–	1 (VCC)	1	–	–	–	–	–
1	OFF	5	5	0	0	0	0	0
	ON	6	6	1	10	10	10	10
2	OFF	7	7	0	0	0	0	0
	ON	8	8	2	20	20	20	20
3	OFF	9	9	0	0	0	0	0
	ON	10	10	4	40	40	20	30
4	OFF	11	11	0	–	0	0	0
	ON	12	12	4	–	40	20	30

Table Q: Configuration of 11713B/C (Option 001) to 84904K/L/M, 84905M, 84906K/L, 84907K/L & 84908M programmable attenuators

From 11713B/C (Option 001)				To attenuators				
Front panel pushbutton		Interface cable		84904K/L/M	84905M	84906K/L	84907K/L	84908M
Attenuator X	LED	Viking connector pin number	10-pin DIP pin number	Attenuation (dB)				
–	–	1 (VCC)	10	–	–	–	–	–
1	OFF	5	1	0	0	0	0	0
	ON	6	2	1	10	10	10	5
2	OFF	7	5	0	0	0	0	0
	ON	8	8	2	20	20	20	10
3	OFF	9	4	0	0	0	0	0
	ON	10	9	4	30	30	40	20
4	OFF	11	6	0	–	0	–	0
	ON	12	7	4	–	30	–	30

Interface Cable Drawings

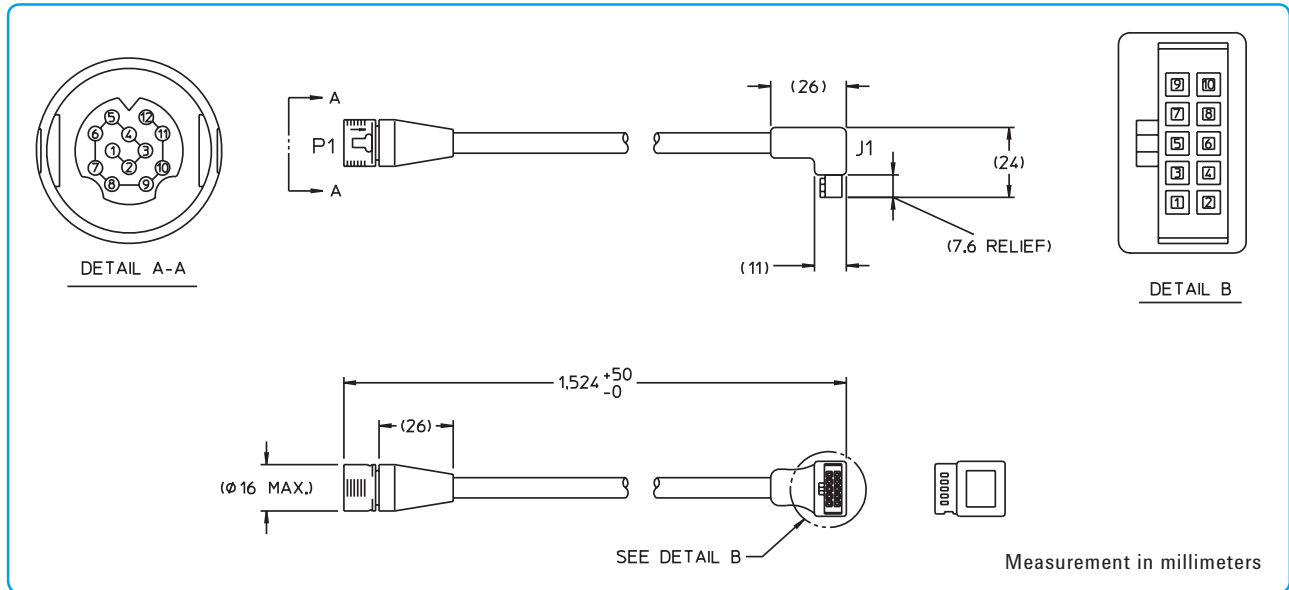

Figure 1. Option 001 viking connector to 10-pin DIP connector

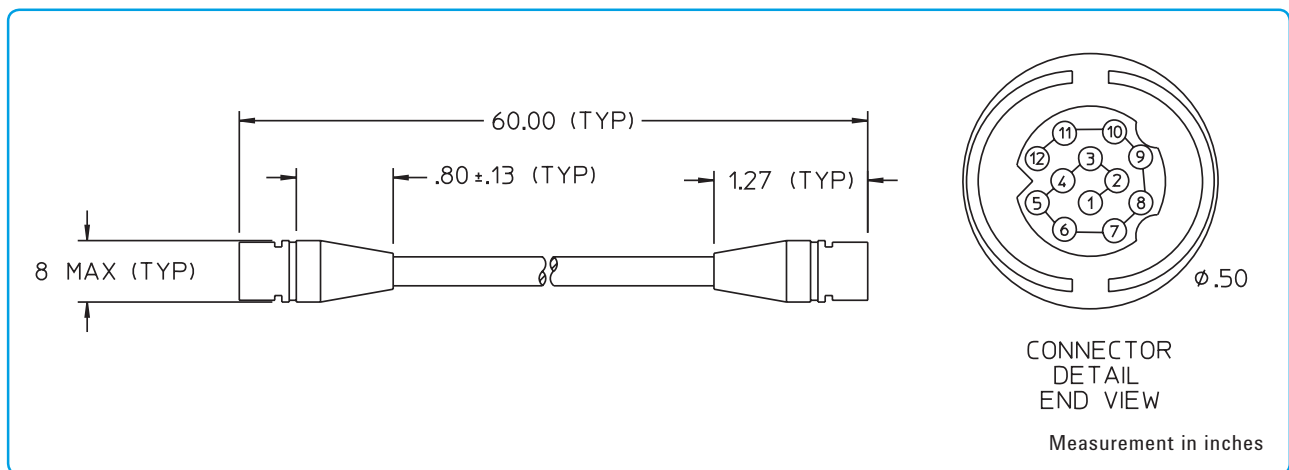

Figure 2. Option 101 viking connector to viking connector

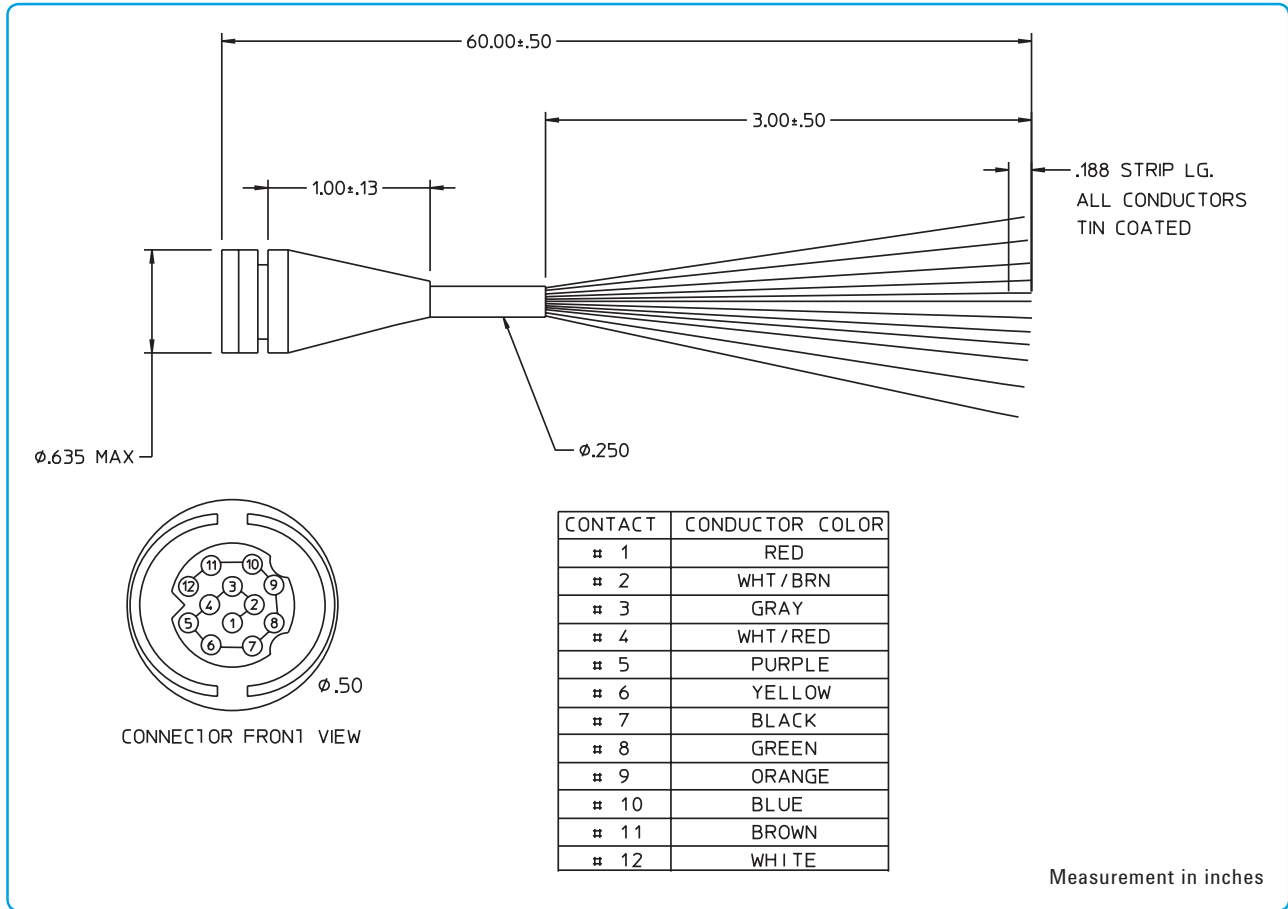

Figure 3. Option 201 viking connector to 12-pin conductor cable, bare wire

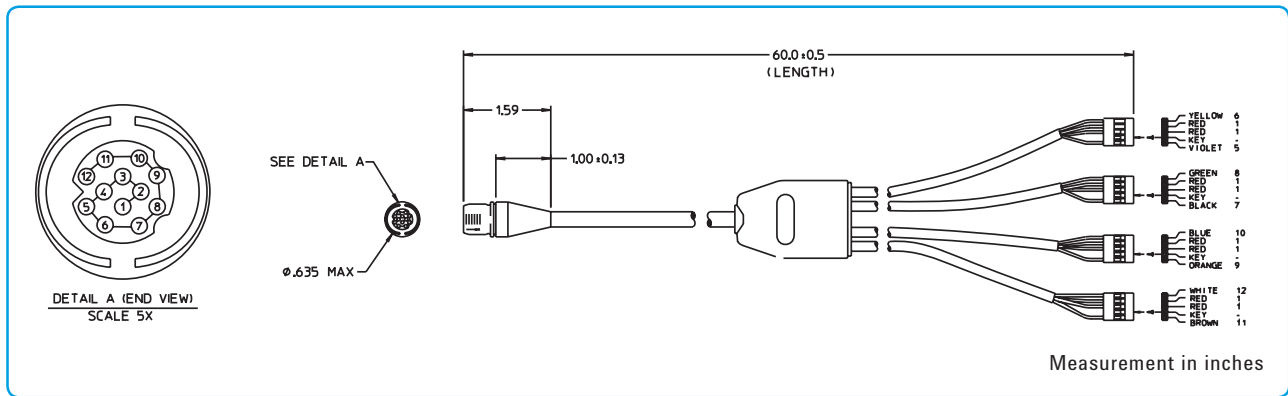

Figure 4. Option 301 viking connector to 4 ribbon cables

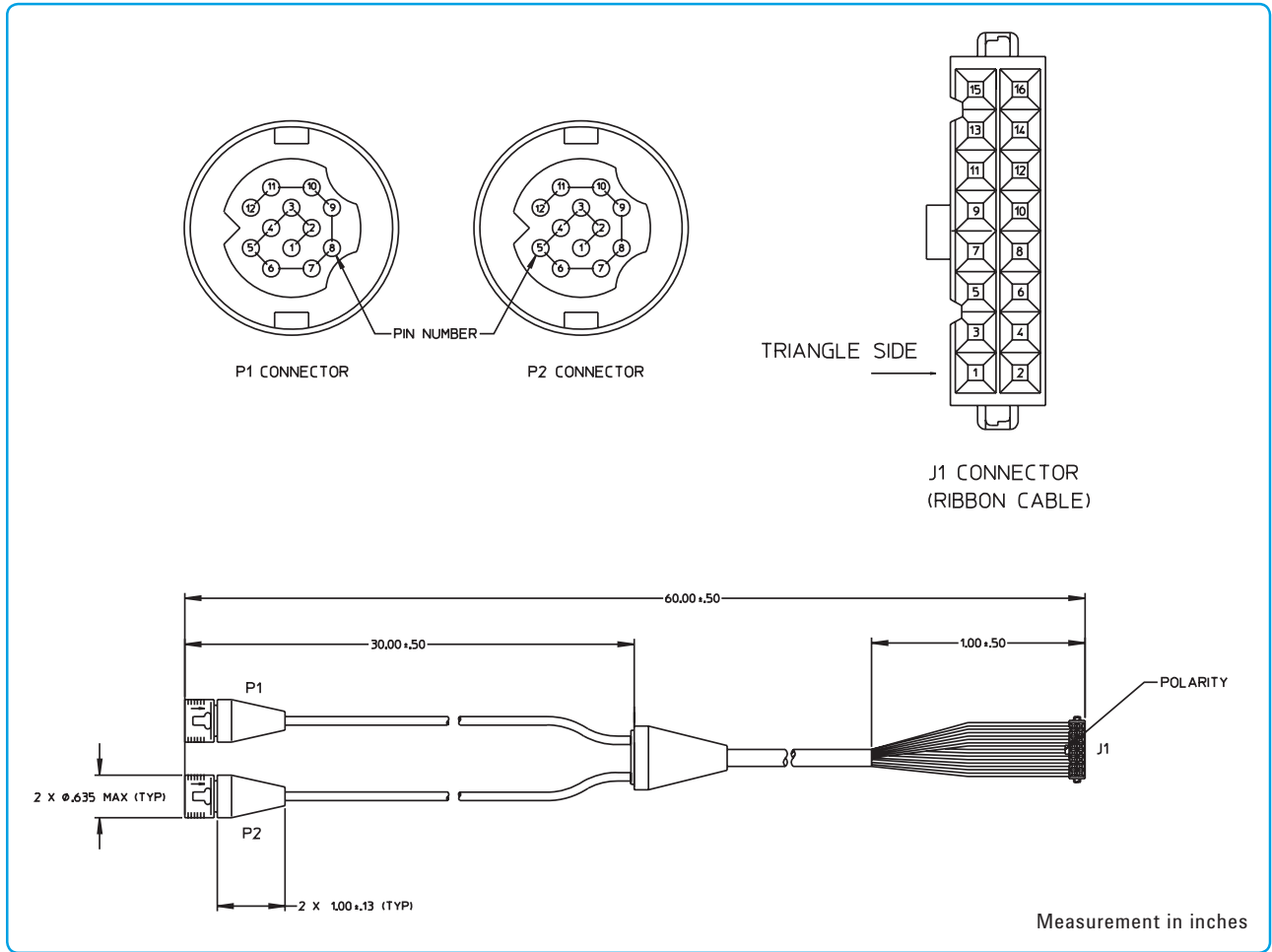

Figure 5. Option 401 dual-viking connector to 16-pin DIP connector

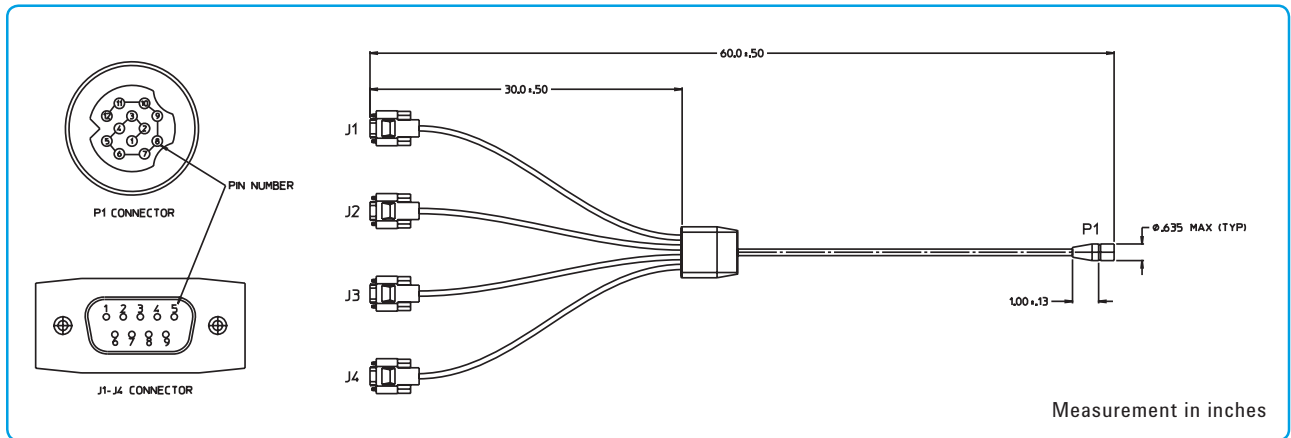

Figure 6. Figure 6. Option 501 viking connector to (4) 9-pin Dsub connectors

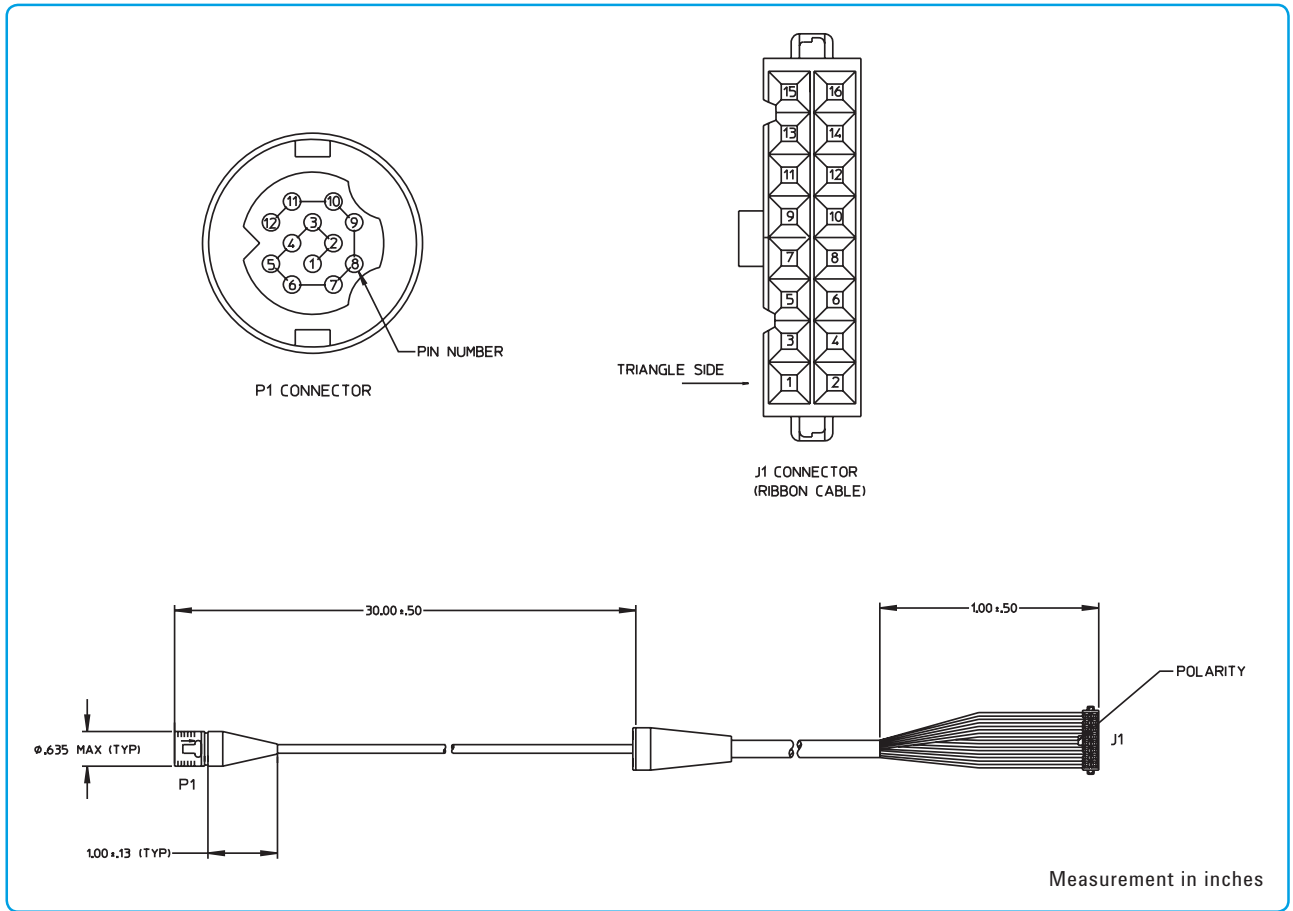

Figure 7. Option 601 viking connector to 16-pin DIP connector

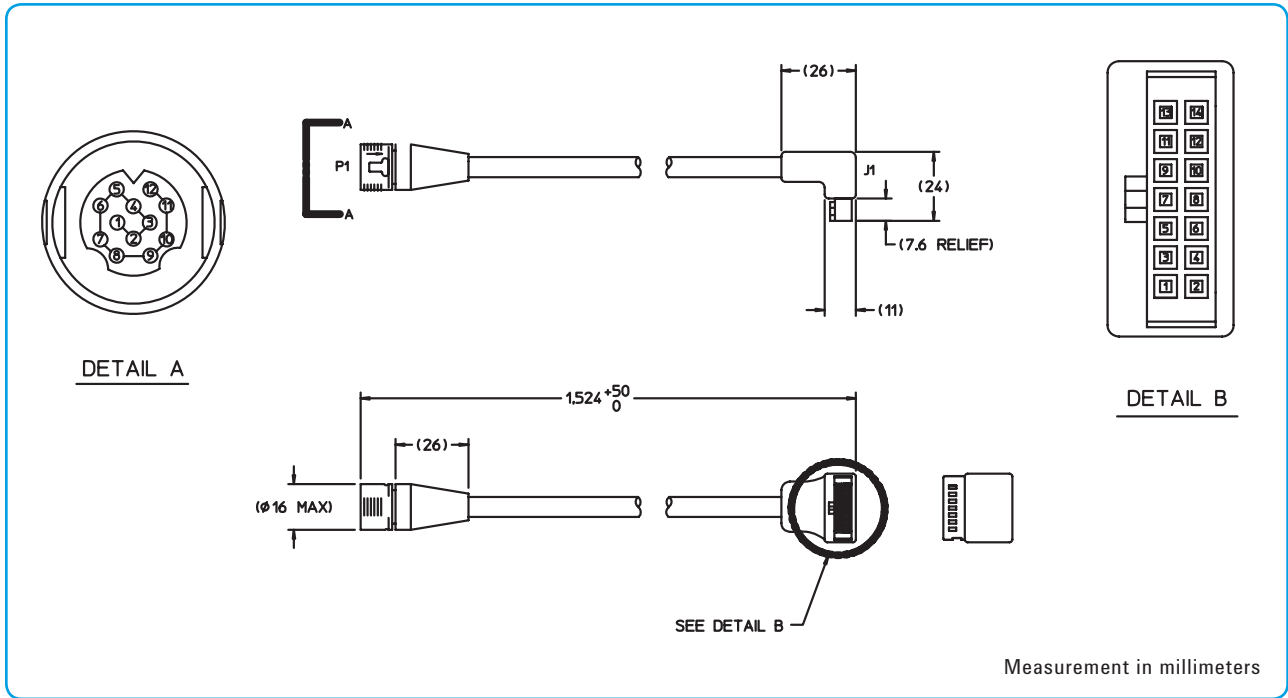

Figure 8. Option 701 viking connector to 14-pin DIP connector

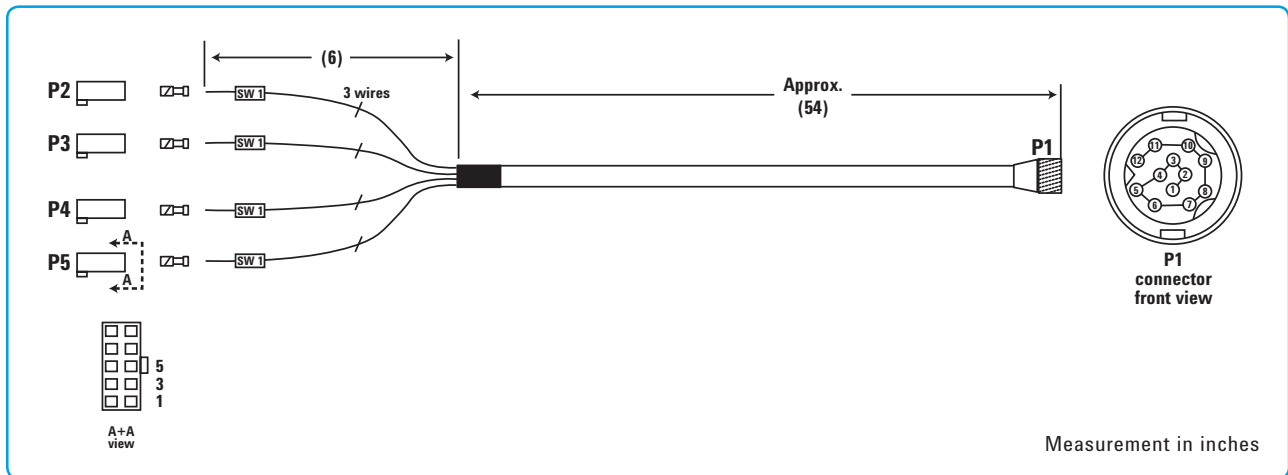

Figure 9. Option 801 viking connector to (4) 10-pin DIP connectors