

THIS DRAWING IS UNPUBLISHED. RELEASED FOR PUBLICATION  
 © COPYRIGHT BY TYCO ELECTRONICS CORPORATION. ALL INTERNATIONAL RIGHTS RESERVED.

LOC	DIST	REVISIONS			
P	LTR	DESCRIPTION	DATE	DWN	APVD
AD	00	SEE SHEET 1	-	-	-

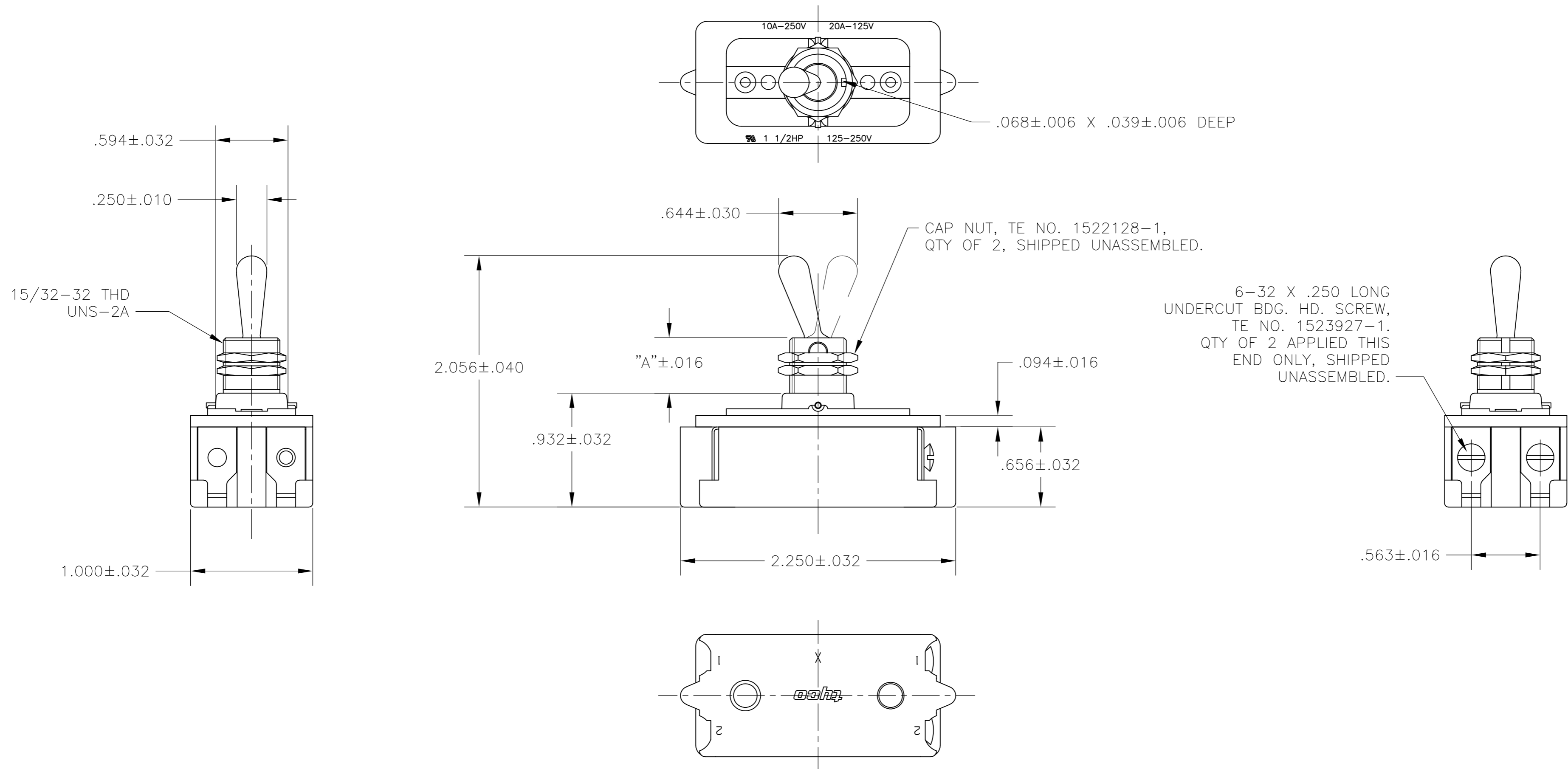

- 1 T-PAK - SWITCH AND HARDWARE INDIVIDUALLY PACKED IN PLASTIC BAGS BEFORE BEING PLACED IN A INTERMEDIATE BOX WHICH IS THEN PLACED IN A SHIPPING BOX. SEE TABLE.
- 2 PLY-O-PAK - SWITCH AND HARDWARE INDIVIDUALLY PACKED IN PLASTIC BAGS BEFORE BEING PACKED LOOSE IN A SHIPPING BOX. SEE TABLE.
- 3 P/N X-6520228-X IS ROHS COMPLIANT.
- 4 MOUNTING DIMENSIONS FOR REFERENCE ONLY.

2-1520228-5/2-6520228-5	7361K5 T-PAK	15/32" THD LENGTH DIE CAST	.469	SPST
1520228-9/6520228-9	8910K191	15/32" THD LENGTH DIE CAST	.469	SPST (PLY-O-PAK)
1520228-5/6520228-5	7361K5	15/32" THD LENGTH DIE CAST	.469	SPST
TE NO.	ARAB NO.	BUSHING / PLATE ASSY	A	DESCRIPTION

THIS DRAWING IS A CONTROLLED DOCUMENT.		DWN J. SMITH 13DEC77	Tyco Electronics Corporation Harrisburg, PA 17105-3608	
DIMENSIONS: INCHES		CHK R. GLENN 13DEC77	NAME	
TOLERANCES UNLESS OTHERWISE SPECIFIED:		APVD M.R. DUMMER 13DEC77	20 AMP 125V AC/DC, 10 AMP 250V AC/DC, 1 1/2 HP 125V/250V AC/DC, ONE HOLE MOUNTING TOOL HANDLE TOGGLE SWITCH	
0 PLC ± -		PRODUCT SPEC	SIZE	RESTRICTED TO
1 PLC ± -		APPLICATION SPEC	A2	-
2 PLC ± -		WEIGHT	00779	-
3 PLC ± -		CUSTOMER DRAWING	C=1520228	-
4 PLC ± -		SCALE NTS	SHEET 3 of 4	REV B1
ANGLES ± -				
FINISH				