

DURACELL[®] COPPERTOP[™]

Alkaline-Manganese Dioxide Battery

MN1604

Size: 9V (6LR61)

Zn/MnO₂

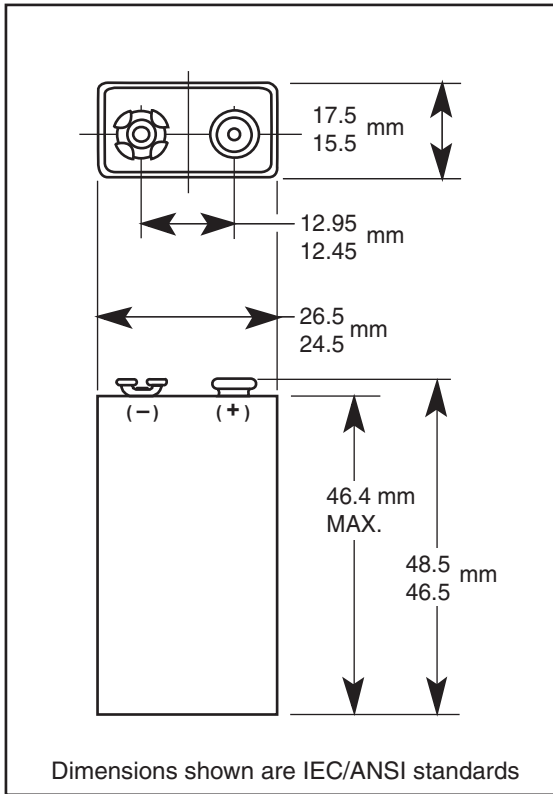

Nominal Voltage:	9 V
Nominal Internal Impedance:	1,700 m-ohm @ 1kHz
Average Weight:	45 gm (1.6 oz.)
Volume:	22.8 cm ³ (1.39 in. ³)
Terminals:	Miniature Snap
Operating Temperature Range:	-20°C to 54°C (-4°F to 130°F)
NEDA/ANSI:	1604A
IEC:	6LR61

TYPICAL DISCHARGE CHARACTERISTICS AT 21 °C (70°F)

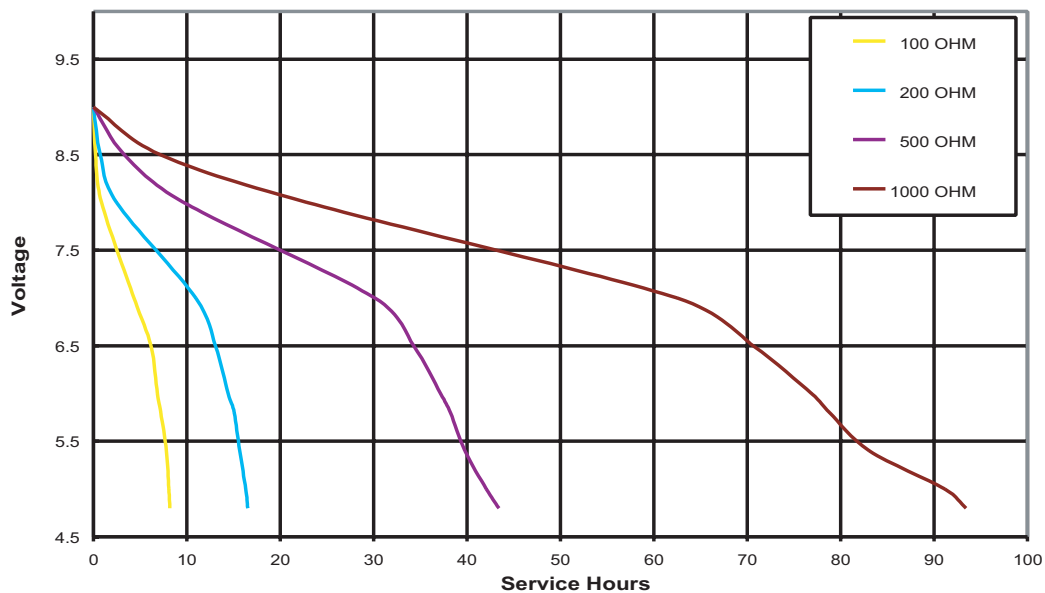

* Delivered capacity is dependent on the applied load, operating temperature and cut-off voltage. Please refer to the charts and discharge data shown for examples of the energy / service life that the battery will provide for various load conditions.

DURACELL®

SPECIFICATION SUMMARY:

SELECTED PRODUCTS

ALKALINE PRIMARY CELLS & BATTERIES

DURACELL® alkaline-manganese dioxide batteries are a popular choice for most consumer, industrial, and military applications where an economical, general purpose battery is required. Advantages include high energy output, reliability, long shelf life, and good low temperature performance.⁽¹⁾ The DURACELL® alkaline battery system is generally available in cylindrical and multicell configurations.

DURACELL PRODUCT NUMBER	SIZE	NOMINAL VOLTAGE (V)	DIMENSIONS ⁽²⁾						NOMINAL WEIGHT		NOMINAL VOLUME		CROSS REFERENCE	
			MAXIMUM		MAXIMUM		MAXIMUM		g	oz.	cm ³	in ³	ANSI	IEC
			mm	in.	mm	in.	mm	in.						

STANDARD CYLINDRICAL CELLS

	SIZE	NOMINAL VOLTAGE (V)	DIAMETER		HEIGHT				NOMINAL WEIGHT		NOMINAL VOLUME		CROSS REFERENCE	
			mm	in.	mm	in.	mm	in.	g	oz.	cm ³	in ³	ANSI	IEC
MN1300	D	1.5	34.2	1.35	61.5	2.42	-	-	139	4.90	56.4	3.44	13A	LR20
MN1400	C	1.5	26.2	1.03	50	1.97	-	-	69.0	2.43	26.9	1.64	14A	LR14
MN1500	AA	1.5	14.5	0.57	50.5	1.99	-	-	23.8	0.84	8.4	0.51	15A	LR6
MN2400	AAA	1.5	10.5	0.41	44.5	1.75	-	-	11.0	0.39	3.8	0.23	24A	LR03
MN9100	N	1.5	12	0.47	30.2	1.19	-	-	9.6	0.34	3.4	0.21	910A	LR1

ULTRA CYLINDRICAL CELLS

	SIZE	NOMINAL VOLTAGE (V)	DIAMETER		HEIGHT				NOMINAL WEIGHT		NOMINAL VOLUME		CROSS REFERENCE	
			mm	in.	mm	in.	mm	in.	g	oz.	cm ³	in ³	ANSI	IEC
MX1300	D	1.5	34.2	1.35	61.5	2.42	-	-	147	5.19	56.4	3.44	13A	LR20
MX1400	C	1.5	26.2	1.03	50.0	1.97	-	-	71.7	2.53	26.9	1.64	14A	LR14
MX1500	AA	1.5	14.5	0.57	50.5	1.99	-	-	24.4	0.86	8.4	0.51	15A	LR6
MX2400	AAA	1.5	10.5	0.41	44.5	1.75	-	-	11.2	0.40	3.8	0.23	24A	LR03
MX2500	AAAA	1.5	8.3	0.33	42.5	1.67	-	-	6.0	0.21	2.3	0.14	25A	LR8D425

OTHER SELECTED MULTICELL BATTERIES

	SIZE	NOMINAL VOLTAGE (V)	LENGTH		HEIGHT		WIDTH		NOMINAL WEIGHT		NOMINAL VOLUME		CROSS REFERENCE	
			mm	in.	mm	in.	mm	in.	g	oz.	cm ³	in ³	ANSI	IEC
MX1604	ULTRA 9-VOLT	9	26.5	1.04	48.5	1.91	17.5	0.69	46.5	1.64	22.8	1.39	1604A	6LR61
MN1604	9-VOLT	9	26.5	1.04	48.5	1.91	17.5	0.69	45.0	1.60	22.8	1.39	1604A	6LR61
7K67	J	6	35.6	1.40	48.5	1.91	9.1	0.36	34.0	1.20	15.7	0.96	1412AP	4LR61
MN908	LANTERN	6	67.0	2.64	115	4.53	67.0	2.64	612	21.6	501.8	30.6	908A	4LR25X
MN918	LANTERN	6	136.5	5.37	127	5.00	73.0	2.87	1270	44.8	1243.5	75.9	918A	4LR25-2
MN1203	LANTERN	4.5	62.0	2.44	67.0	2.64	22.0	0.87	154	5.43	91.4	5.58	-	3LR12
MN21	CYLINDRICAL	12	10.3	0.41	28.5	1.12	-	-	7.40	0.26	2.30	0.14	-	-

(1) Operating temperature range is -20°C to 54°C (-4°F to 130°F)

(2) Dimensions are IEC/ANSI standards.

1

Introduction

Duracell pioneered the alkaline-manganese dioxide electrochemical system nearly 40 years ago. In the 1960-1970 decade, this battery system rapidly became the popular choice of designers in the ever-widening field of consumer electronics. The product information and test data included in this technical bulletin represent Duracell's newest alkaline battery products.

The zinc/potassium hydroxide/manganese dioxide cells, commonly called alkaline or alkaline-manganese dioxide cells, have a higher energy output than zinc-carbon (Leclanche) cells. Other significant advantages are longer shelf life, better leakage resistance, and superior low temperature performance. In comparison to the zinc-carbon cell, the alkaline cell delivers up to ten times the ampere-hour capacity at high and continuous drain conditions, with its performance at low temperatures also being superior to other conventional aqueous electrolyte primary cells. Its more effective, secure seal provides excellent resistance to leakage and corrosion.

The use of an alkaline electrolyte, electrolytically prepared manganese dioxide, and a more reactive zinc powder contribute to a higher initial cost than zinc-carbon cells. However, due to the longer service life, the alkaline cell is actually more cost-effective based upon cost-per-hour usage, particularly with high drains and continuous discharge. The high-grade, energy-rich materials composing the anode and cathode, in conjunction with the more conductive alkaline electrolyte, produce more energy than could be stored in standard zinc-carbon cell sizes.

2

General Characteristics

The general characteristics listed below are a summary of the significant benefits of the alkaline manganese dioxide system. Each of the benefits is explained in greater detail subsequently in Section 5. This summary provides the designer with general guidelines for evaluating the alkaline-manganese dioxide system for a particular application.

Benefits include:

- Up to ten times the service life of regular zinc-carbon cells.
- Long service life at continuous, high drain discharge.
- No need for "rest periods."
- Low internal resistance.
- Rugged, shock-resistant construction.
- Cost-effective on a cost-per-hour-of-service basis.
- Good low temperature performance.
- Excellent leakage resistance.
- Long shelf life.
- Worldwide availability at retail.

Performance Characteristics (cont.)

performance of alkaline and regular zinc-carbon cells is compared in **Figure 9**, showing the “D” size cell at 70°F (21°C) and 32°F (0°C). **Figure 9a** shows “AA” cell performance under the same conditions. The alka-

line cell will maintain a higher voltage for considerably longer than the regular zinc-carbon cell, resulting in a service life at lower temperatures which is up to ten times that of the regular zinc-carbon cell.

5.5 Internal Resistance

Alkaline cells, because of their compact construction and highly conductive electrolyte, have low internal resistance, usually less than 1 ohm. The low internal resistance characteristic is a benefit in applications

involving high current pulses. Unlike regular zinc-carbon cells, alkaline cells do not require rest periods between pulses and maintain their low internal resistance, increasing only at the very end of useful life.

5.6 Energy Density

Energy density is a measure of available energy in terms of weight and volume. It is the ratio of a cell's capacity to either its volume or weight and can be used to evaluate a cell's performance.

Table 1 is a summary of the major alkaline product types comparing both volumetric energy density and gravimetric energy density. Volumetric energy density

is an important factor where battery size is the primary design consideration. Gravimetric energy density becomes important where weight of the battery is critical, such as in portable computers and cellular phones. The values shown in this table are typical for each cell size. Actual energy output will vary, dependent mostly on drain rates applied.

PRODUCT NUMBER	SIZE	NOMINAL VOLTAGE	RATED CAPACITY*	LOAD	WEIGHT		VOLUME		TYPICAL GRAVIMETRIC ENERGY DENSITY**		TYPICAL VOLUMETRIC ENERGY DENSITY	
		volts	ampere-hours	ohms	pounds	kilograms	cubic inches	liters	watt-hours per pound	watt-hours per kilogram	watt hours per cubic inch	watt hours per liter
MN1300	D	1.5	15.000	10	0.304	0.138	3.440	0.056	59.2	130	5.2	322
MN1400	C	1.5	7.800	20	0.143	0.065	1.640	0.027	65.5	144	5.7	347
MN1500	AA	1.5	2.850	43	0.052	0.024	0.510	0.008	65.8	143	6.7	428
MN2400	AAA	1.5	1.150	75	0.024	0.011	0.230	0.004	57.5	126	6.0	345
MN9100	N	1.5	0.800	100	0.021	0.010	0.210	0.003	45.7	96	4.6	320
7K67	J	6.0	0.580	340	0.075	0.034	0.960	0.016	37.2	82	2.9	174
MN908	Lantern	6.0	11.500	15	1.349	0.612	30.620	0.502	40.9	90	1.8	110
MN918	Lantern	6.0	24.000	9	2.800	1.270	75.880	1.243	41.1	91	1.5	93
MN1604	9V	9.0	0.580	620	0.101	0.046	1.390	0.023	41.4	91	3.0	182

* TO 0.8V per cell at 21°C (70°F).

** Based on 1.2 volt average operating voltage per cell at 21°C (70°F).

Table 1. Comparison of typical energy densities of major DURACELL® alkaline cells/batteries.

To determine the practical energy density of a cell under specific conditions of load and temperature, multiply the ampere-hour capacity that the cell delivers under those conditions by the average discharge voltage, and divide by cell volume or weight.

Gravimetric Energy Density:

$$\frac{(\text{Drain in Amperes} \times \text{Service Hours}) \times \text{Average Discharge Voltage}}{\text{Weight of cell in Pounds or Kilograms}} = \frac{\text{Watt-Hours}}{\text{Pound or Kilogram}}$$

Volumetric Energy Density:

$$\frac{(\text{Drain in Amperes} \times \text{Service Hours}) \times \text{Average Discharge Voltage}}{\text{Volume of cell in Cubic Inches or Liters}} = \frac{\text{Watt-Hours}}{\text{cubic Inch or Liter}}$$

6 Applications

DURACELL[®] alkaline batteries—with their superior drain rate characteristics, good shelf storage life, low internal resistance, and wide operating temperature range—are a popular choice for many portable power applications. The most common uses are found in the consumer market, in applications such as photographic equipment, remote control devices, toys, electronic games, flashlights, tape recorders, home health care devices, radios, shavers, clocks, calculators, and computers.

Alkaline cells also have significant application presence in the industrial and government sectors. Some industrial applications include portable medical and

industrial instrumentation, portable and emergency lighting products, communications equipment, and portable electrical measurement devices. Military applications include a variety of communication devices and general instrumentation.

Duracell is actively involved in the development of battery products that can power applications currently utilizing rechargeable batteries or AC power, such as notebook computers, handheld cellular phones, camcorders, power tools, and more. The goal of this development program is to provide customers with a primary battery option where needed.

7 Battery Care

7.1 Storage Conditions

Batteries should be stored at temperatures between 50°F (10°C) and 77°F (25°C), with relative humidity not exceeding 65 percent. Refrigeration of alkaline batteries is not necessary because of their very

good capacity retention. Excessive temperature cycling and storage at temperatures greater than 77°F (25°C) should be avoided to maximize shelf life.

7.2 Proper Usage and Handling

Discharged batteries should be removed from equipment to prevent possible damage. Batteries should be removed from a device when it is not expected to be in use for several months. Batteries should also be removed from equipment while it is being powered by household (AC) current. Always replace all batteries at the same time since batteries in series, in different states of discharge, may eventually drive the weakest battery into voltage reversal with progressive risk of leak age or rupture. Mixing battery systems, such as

alkaline with zinc-carbon, may also result in voltage reversal and should be avoided.

Always replace the battery or batteries in your equipment with the size and type of battery specified by the equipment manufacturer.

Keep batteries away from small children. If swallowed, consult a physician at once. (For information on treatment, telephone the National Capital Poison Center, Washington, D.C., at 202-625-3333 collect.)

7.3 Charging

All batteries listed in this bulletin are of the primary type and are not designed to be recharged. Attempts to recharge an alkaline battery may cause an

imbalance within the cell, leading to gassing and possibly explosion on either charge or discharge cycles.