



Open Racks
Double Rack



Design Features

Light weight but sturdy aluminum and steel construction
Solid and sturdy 4-point mounting
#12-24 Tapped equipment mounting holes on EIA universal centers (5/8", 5/8", 1/2")
Fixed depth members allow mounting of wiring ladder and/or cableway
Quickly assembled with one 5/8" wrench
Can be joined together in multiple bay configurations with optional Add-A-Rack kits
Meets EIA-310 standards
Floor mounting holes

Bonus Features

Optional **Adjusting Brackets** allow mounting of a mix of different depth equipment.
AB-8089 (1.75"H X 8.00"D). Sold in pairs.

Optional full-height intermediate **Adjusting Panel Mounting Rails** allow mounting of a gang of different depth equipment.

PMR-8088 (75.25"H Panel Space). Sold in pairs.

Optional **Adjustable Shelf**

SH-8096 (3.50"H x 24.00" to 36.00"D)

Optional **Add-A-Rack kit** allows joining of multiple racks while maintaining sealing integrity.

HW-8097

Accepts most Bud standard accessories

Shipped knockdown in one carton

Finishes

Black Textured. Other finishes available upon request

Double Rack			
Catalog Number	Drawings	Panel Space	Dimensions
DR-8092		77.00" x 19.00"	84.00"H x 20.25"W x 24.00"D
DR-8093		77.00" x 19.00"	84.00"H x 20.25"W x 30.00"D
DR-8094		77.00" x 19.00"	84.00"H x 20.25"W x 36.00"D

Accessories for Double Rack				
Picture	Catalog Number	Name	Drawings	Size
	SH-8096	Adjustable Shelf		19"PW x 3.5"H

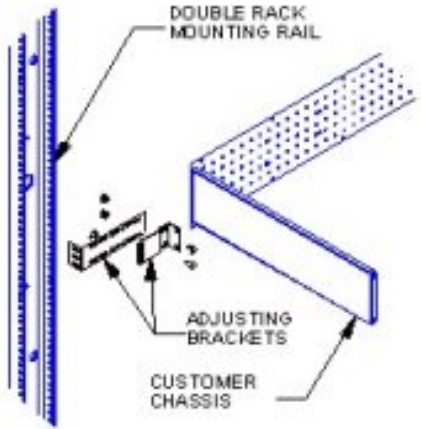
	<p>PMR-8088</p>	<p>Adjustable Mounting Rail</p>		<p>75.25" (43U)</p>
	<p>AB-8089</p>	<p>Adjusting Brackets</p>		<p>1.75" x 8.00"</p>
<p>N/A</p>	<p>HW-8097</p>	<p>Add-A-Rack Hardware Kit</p>	<p>N/A</p>	<p>--</p>

PART NAME

DOUBLE RACK

PART No.

DR-8092, DR-8093, DR-8094

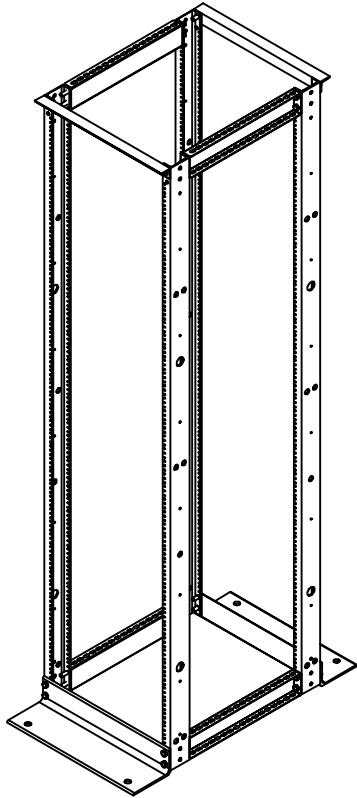

MATERIAL:

UPRIGHTS, BASE & TOP ANGLES _____ ALUMINUM EXTRUSIONS
 EXTENDERS _____ 14 GA. STEEL

FINISH: BLACK TEXTURE

UPRIGHTS ARE TAPPED #12-24 ON E.I.A. UNIVERSAL SPACING.
 UNIT IS SHIPPED KNOCKED DOWN.

LOAD RATING: 1200 LBS. MAX.

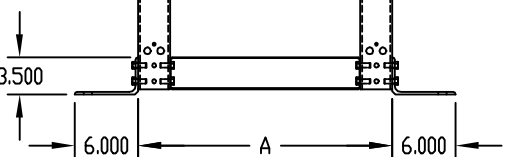
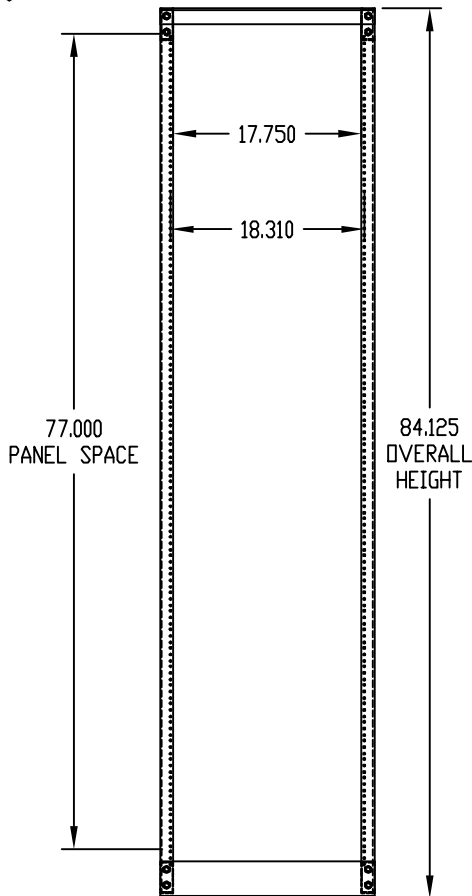
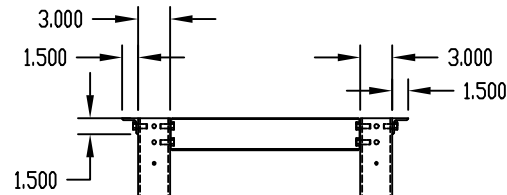
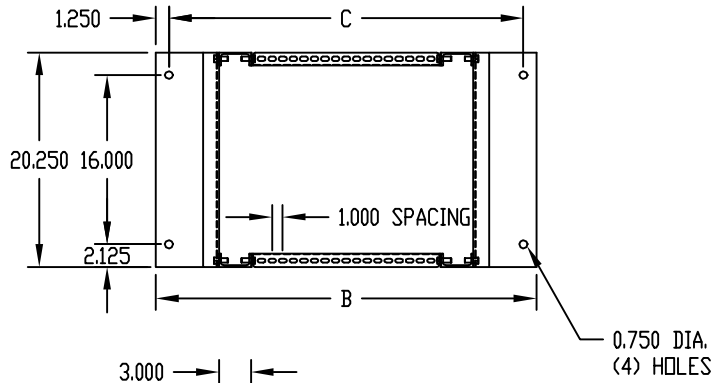

PART NO.	A	B	C
DR-8092	24.000	36.000	33.500
DR-8093	30.000	42.000	39.500
DR-8094	36.000	48.000	45.500