

SNAP Power Monitoring Modules

Features

- Convenient pluggable wiring
- Single-phase or three-phase power monitoring
- Monitors AC RMS voltage and AC RMS current; calculates true power and volt-amps
- 10% over range
- 25,000 counts of resolution over input ranges
- Out-of-range indication
- Factory calibrated; no user adjustment necessary

Description

SNAP power-monitoring analog input modules provide an efficient way to monitor AC voltage and current using a SNAP PAC rack-mounted controller or SNAP PAC brain. These modules can be used with both standard wired SNAP PAC brains and controllers and Wired+Wireless™ models.

Three power-monitoring modules are available:

- The **SNAP-AIPM** monitors single-phase AC power.
- The **SNAP-AIPM-3** monitors three-phase AC power using a standard current transformer (CT).
- The **SNAP-AIPM-3V** monitors three-phase AC power using a 0.333 VAC current transformer (CT).

All modules mount on a SNAP PAC rack right alongside digital, analog, and serial SNAP I/O™ modules.

SNAP power-monitoring modules help you measure and control power usage, so you can reduce costs, maintain power quality, and track energy use. If they are part of a SNAP PAC System running a PAC Control™ strategy, strategy logic can automatically perform additional calculations and respond to any problems the module reports.

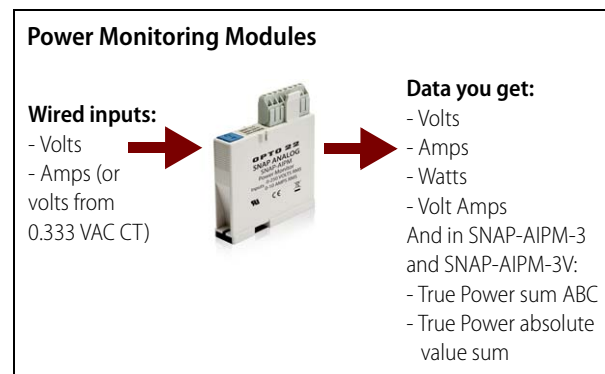

SNAP-AIPM Module

SNAP racks use a retention rail locking system that holds modules securely to the rack. Normally, a hold-down screw is not required. However, for applications that require additional module security, each module has provisions for two 4-40 by ½-inch standard machine screws to hold each module in position on the SNAP rack.

SNAP-AIPM

The SNAP-AIPM individually and simultaneously measures single-phase AC volts RMS and amps RMS and calculates true power and volt-amps. Power factor can then be calculated from true power and volt-amp values. Because true power is a signed value, either leading or lagging power factor can be calculated.

The SNAP-AIPM module is designed for 85–250 volts and 0–10 amps, but it can also monitor AC line currents greater than 10 amps using a standard current transformer (CT) of suitable ratio. For line voltage larger than 250 VAC, use a step-down potential transformer. If hazardous voltage or current is to be monitored, an interposing potential transformer and a CT **must** be used for safety.

Part Number

Part	Description
SNAP-AIPM	Single-phase Power Monitoring Module, 85–250 V RMS and 0–10 A RMS Inputs
SNAP-AIPM-3	Three-phase Power Monitoring Module, 85–300 V RMS and 0–5 A RMS Inputs for Each Phase
SNAP-AIPM-3V	Three-phase Power Monitoring Module, 85–300 V RMS and 0–0.333 VAC CT Inputs for Each Phase

SNAP Power Monitoring Modules

The SNAP-AIPM module offers four channels (points) of data, two from wired inputs and two calculated by the module:

Pt	Data	Data Source
0	0–250 AC VRMS	Measured from VRMS input
1	0–10 AC ARMS	Measured from ARMS input
2	True Power	Calculated from synchronous measurement of volts and amps
3	Volt-Amps	Calculated (VRMS x ARMS)

To calculate power factor, simply use the data in points 2 and 3 in the formula: Power Factor = (True Power Magnitude) / (volt-amps).

SNAP-AIPM-3

The SNAP-AIPM-3 provides 14 channels of data, some from wired inputs and some calculated by the module. For each of the three phases, the module includes the same four channels as in the SNAP-AIPM (see previous page); in addition, it includes two summation values. Calculations occur within the module and are available to the SNAP PAC brain or rack-mounted controller. All channels are shown in the table below.

CTs must be used for current inputs. Potential transformers are required for voltage inputs when voltage exceeds 300 VAC.

Required: Brain firmware 9.1b and PAC Project 9.1a or newer.

Data Channels for SNAP-AIPM-3

Pt	Data	Data Source
0	0–300 AC VRMS	Phase A: Measured from VRMS input
1	0–5 AC ARMS	Phase A, from ARMS input
2	True Power	Phase A: Calculated from synchronous measurement of volts and amps
3	Volt-Amps	Phase A: Calculated (VRMS x ARMS)
4	0–300 AC VRMS	Phase B: Measured from VRMS input
5	0–5 AC ARMS	Phase B, from ARMS input
6	True Power	Phase B: Calculated from synchronous measurement of volts and amps
7	Volt-Amps	Phase B: Calculated (VRMS x ARMS)
8	0–300 AC VRMS	Phase C: Measured from VRMS input
9	0–5 AC ARMS	Phase C, from ARMS input
10	True Power	Phase C: Calculated from synchronous measurement of volts and amps
11	Volt-Amps	Phase C: Calculated (VRMS x ARMS)
12	1-second energy sum	True Power sum ABC (signed)
13	1-second abs energy sum	True Power sum of absolute value of each A, B, and C (always positive)

SNAP-AIPM-3V

The SNAP-AIPM-3V also provides 14 channels of data, some from wired inputs and some calculated by the module. All channels are shown in the table below.

The SNAP-AIPM-3V requires CTs with a 0.333 VAC secondary. These CTs are safer and less expensive than the CTs used with the SNAP-AIPM-3. See the [Split-Core Current Transformers Data Sheet](#) (form 1938) for suitable CTs available through Opto 22.

Required: Brain firmware 9.1b and PAC Project 9.1a or newer.

Data Channels for SNAP-AIPM-3V

Pt	Data	Data Source
0	0–300 AC VRMS	Phase A: Measured from VRMS input
1	0–0.333 VAC	Phase A, from ARMS input
2	True Power	Phase A: Calculated from synchronous measurement of volts and amps
3	Volt-Amps	Phase A: Calculated (VRMS x ARMS)
4	0–300 AC VRMS	Phase B: Measured from VRMS input
5	0–0.333 VAC	Phase B, from ARMS input
6	True Power	Phase B: Calculated from synchronous measurement of volts and amps
7	Volt-Amps	Phase B: Calculated (VRMS x ARMS)
8	0–300 AC VRMS	Phase C: Measured from VRMS input
9	0–0.333 VAC	Phase C, from ARMS input
10	True Power	Phase C: Calculated from synchronous measurement of volts and amps
11	Volt-Amps	Phase C: Calculated (VRMS x ARMS)
12	1-second energy sum	True Power sum ABC (signed)
13	1-second abs energy sum	True Power sum of absolute value of each A, B, and C (always positive)

Isolation

All SNAP analog input modules, including the SNAP-AIPM, SNAP-AIPM-3, and SNAP-AIPM-3V, are transformer isolated as well as optically isolated from all other modules and from the SNAP PAC brain or rack-mounted controller.

Optical isolation provides 4,000 volts of transient (4,000 V for 1 ms) protection for sensitive control electronics from industrial field signals. Transformer isolation prevents ground loop currents from flowing between field devices and causing noise that produces erroneous readings. Ground loop currents are caused when two grounded field devices share a connection, and the ground potential at each device is different.

However, note that the input points on the modules in this data sheet are *not* isolated from each other. Because they share the same reference terminal, polarity must be observed.

SNAP Power Monitoring Modules

Note for legacy hardware: The SNAP-AIPM module can also be used with SNAP Ultimate, SNAP Ethernet, and SNAP Simple brains and on a SNAP M-series or B-series mounting rack.

The SNAP-AIPM-3 and SNAP-AIPM-3V cannot be used with legacy hardware. They require a SNAP PAC brain or rack-mounted controller. The SNAP-AIPM-3 and SNAP-AIPM-3V require brain firmware version 9.1b or newer and PAC Project version 9.1a or newer.

Specifications: SNAP-AIPM

SNAP-AIPM	
Voltage Inputs (each voltage channel)	
Recommended Input Range	85 to 250 VAC RMS
Scaled Input Range	0 to 250 VAC RMS
Input Over Range	To 275 volts
Resolution	10 mV
Accuracy (47 to 63 Hz)	(When used within recommended range) ± 0.2 V plus ± 0.2% reading (at full scale = ± 0.7 V or 0.28%)
RMS Integration Time/ Data Freshness	1000 ms (synchronous with current measurement)
Input Filtering	Time constant = 70 μs (analog front end) (−0.2 dB at 660 Hz; −3 dB at 1.89 kHz) nominal
Input Resistance – Single Ended	1 Megohm NOTE: Because both channels share the same reference terminal, polarity must be observed when connecting the current channel.
Maximum Input	300 V non-operating
Current Inputs (each current channel)	
Input Range	0 to 10 AC amps RMS
Input Over Range	To 11 amps (Reading is not reliable over 11 A.)
Input Overload	15 A continuous, non-operating
Resolution	400 μA
Accuracy (47 to 63 Hz)	± 8 mA plus ± 0.2% reading (at full scale = ± 28 mA or 0.28%)
RMS Integration Time/ Data Freshness	1000 ms (synchronous with voltage measurement)
Input Filtering	Time constant = 105 μs (analog front end) (−0.2 dB at 660 Hz; −3 dB at 1.89 kHz) nominal
Input Resistance – Single Ended	0.005 Ohm NOTE: Because both channels share the same reference terminal, polarity must be observed when connecting the voltage channel.
Maximum Input	15 A continuous, non-operating
Calculated Channels	
True Power and Volt-Amps Range	True power: 2500.0 Watts. Volt-amps: 2500.0 volt-amps (= 25,000 counts) (inputs = 250 volts and 10 amps)
Over Range	2750 Watts true power or 2750 Volt-amps (= 27,500 counts)
Accuracy:	
True Power	± 0.6% reading (at full scale = ± 15 Watts)
Volt-Amps	± 0.6% reading (at full scale = ± 15 VA)
Resolution	100 mW with default scaling
AC Common Mode Rejection	> −120 dB at 60 Hz

SNAP Power Monitoring Modules

SNAP-AIPM	
Maximum Operating Common Mode Voltage	250 VAC
Calculated Outputs	
True Power	0–2500 W (from synchronous measurement of volts and amps)
Volt Amps	0–2500 VA (VRMS x ARMS)
General Specifications	
Power Requirements	5.0 VDC \pm 0.15 VDC at 100 mA
Ambient Temperature:	
Operating	0 to 70 °C
Storage	-40 to 85 °C
Wire size	22 to 14 AWG
Torque, hold-down screws	4 in-lb (0.45 N-m)
Torque, connector screws	5.26 in-lb (0.6 N-m)
Agency Approvals	CE, RoHS, DFARS
Warranty	Lifetime

Specifications: SNAP-AIPM-3 and SNAP-AIPM-3V

	SNAP-AIPM-3	SNAP-AIPM-3V
Voltage Inputs (each voltage channel)		
Recommended Input Range	85 to 300 VAC RMS*	85 to 300 VAC RMS*
Scaled Input Range	0 to 300 VAC RMS	0 to 300 VAC RMS
Input Over Range	To 330 volts	To 330 volts
Resolution	12 mV	12 mV
Accuracy (47 to 63 Hz)	(When used within recommended range) ± 0.2 V plus $\pm 0.2\%$ reading (at full scale = ± 0.7 V or 0.28%)	(When used within recommended range) ± 0.2 V plus $\pm 0.2\%$ reading (at full scale = ± 0.2 V + ± 0.8 V = ± 1.0 V)
RMS Integration Time/ Data Freshness	1000 ms (synchronous with current measurement)	1000 ms (synchronous with current measurement)
Input Filtering	Time constant = 70 μ s (analog front end) (-0.2 dB at 660 Hz; -3 dB at 1.89 kHz) nominal	Time constant = 70 μ s (analog front end) (-0.2 dB at 660 Hz; -3 dB at 1.89 kHz) nominal
Input Resistance – Single Ended	1 Megohm NOTE: Because both channels share the same reference terminal, polarity must be observed when connecting the current channel.	1 Megohm NOTE: Because both channels share the same reference terminal, polarity must be observed when connecting the current channel.
Maximum Input	330 V non-operating	330 V non-operating
Current Inputs (each current channel)		
Input Range	0 to 5 AC amps RMS*	0 to 0.333 VAC current transformer input
Input Over Range	To 5.5 amps (Reading is not reliable over 5.5 A)	To 0.366 VAC
Input Overload	15 A continuous, non-operating	5 VAC continuous, non-operating
Resolution	200 μ A	13.3 μ V AC
Accuracy (47 to 63 Hz)	± 4 mA plus $\pm 0.2\%$ reading (at full scale = ± 28 mA or 0.28%)	± 266 microvolts plus 0.2% of reading (at full scale = 266 μ V + 667 μ V = 933 μ V = 0.28%)

SNAP Power Monitoring Modules

	SNAP-AIPM-3	SNAP-AIPM-3V
RMS Integration Time/ Data Freshness	1000 ms (synchronous with voltage measurement)	1000 ms (synchronous with voltage measurement)
Input Filtering	Time constant = 105 μ s (analog front end) (-0.2 dB at 660 Hz; -3 dB at 1.89 kHz) nominal	Time constant = 105 μ s (analog front end) (-0.2 dB at 660 Hz; -3 dB at 1.89 kHz) nominal
Input Resistance – Single Ended	0.005 Ohm NOTE: Because both channels share the same reference terminal, polarity must be observed when connecting the voltage channel.	500 K Ohms NOTE: Because both channels share the same reference terminal, polarity must be observed when connecting the voltage channel.
Maximum Input	15 A continuous, non-operating	5 VAC continuous, non-operating
Calculated Channels		
True Power and Volt-Amps Range	True power: 1500.0 Watts. Volt-amps: 1500.0 volt-amps (inputs = 300 volts and 5 amps)	True power and volt-amps are calculated from 300 volts and the full-scale current input of your 0.333 VAC output CT.
Over Range	1650 Watts true power or 16,500 counts volt-amps	Depends on CT selection
Accuracy: True Power Volt-Amps	\pm 0.6% reading (at full scale = \pm 15 Watts) \pm 0.6% reading (at full scale = \pm 15 VA)	\pm 0.6% reading \pm 0.6% reading
Resolution	100 mW with default scaling	Depends on CT selection
AC Common Mode Rejection	> -120 dB at 60 Hz	> -120 dB at 60 Hz
Maximum Operating Common Mode Voltage	300 VAC	300 VAC
Calculated Outputs		
True Power	0–1500 W (from synchronous measurement of volts and amps)	W (from synchronous measurement of volts and amps)**
Volt Amps	0–1500 VA (VRMS x ARMS)	VA (VRMS x ARMS)**
1-second Energy Sum	0–4500 joules (true power sum ABC, signed)	Joules (true power sum ABC, signed)**
1-second abs Energy Sum	0–4500 joules (true power sum of absolute value of each A, B, and C, always positive)	Joules (true power sum of absolute value of each A, B, and C, always positive)**
General Specifications		
Power Requirements	5.0 VDC \pm 0.15 VDC at 100 mA	5.0 VDC \pm 0.15 VDC at 100 mA
Ambient Temperature: Operating Storage	0 to 70 °C -40 to 85 °C	0 to 70 °C -40 to 85 °C
Agency Approvals	CE, RoHS, DFARS	CE, RoHS, DFARS
Warranty	Lifetime	Lifetime

*Inputs on older modules were 0–250 V and for SNAP-AIPM-3, 0–10 A. Before wiring or scaling, check printed information on the module to make sure you are using the correct voltage and current. Contact Opto 22 Product Support with any questions.

**Values depend on CT selection.

Important Notes on Wiring

Wiring should be done by a licensed electrician. Be sure to use appropriate CTs, and never mix CT types on the same device. The wrong CT can cause severe damage to equipment.

For the SNAP-AIPM-3V module, suitable CTs with a 0.333 VAC secondary are available from Opto 22. See form #1938, the [Split-Core Current Transformers Data Sheet](#), for more information.

IMPORTANT—Voltage change: Older SNAP-AIPM-3 and SNAP-AIPM-3V modules (manufactured before April 2011) were designed with an input range of 0–250 volts (*not* 0–300 V) for points 0, 4, and 8. Older SNAP-AIPM-3 modules used 0–10 A (*not* 0–5). Before wiring or scaling, check the printed information on the module to make sure you are using the correct voltage and current. Older modules can be exchanged for newer ones; contact Product Support for information.

Wiring diagrams begin on [page 11](#).

Scaling

If you are using PAC Control, when you configure the points on SNAP power monitoring modules, you must scale them to match the CT you use. Scaling must be accurate for the resulting data to be accurate. The examples starting on [page 7](#) can help you determine the correct values for your CT and module.

IMPORTANT: For *all* installations of 85 to 300 VAC (or 85–250 for the SNAP-AIPM), both Actual and Scaled Volts (point 0 on all modules, plus points 4 and 8 on the SNAP-AIPM-3 and SNAP-AIPM-3V) should remain at the default: 0–250 VAC for the SNAP-AIPM and 0–300 VAC for the SNAP-AIPM-3 and SNAP-AIPM-3V.

However, for installations over 300 VAC (250 for the SNAP-AIPM), you will need to scale these points. For help, see [“Scaling Example 2: SNAP-AIPM with PT” on page 8](#), [“Scaling Example 4: SNAP-AIPM-3 with PT” on page 9](#), or [“Scaling Example 6: SNAP-AIPM-3V with PT” on page 10](#). Note that these examples of higher line voltage require you to use a step-down potential transformer.

Steps for Scaling Modules in PAC Control

NOTE: SNAP-AIPM-3 and SNAP-AIPM-3V require brain firmware 9.1b or newer and PAC Control 9.1a or newer.

1. In PAC Control, open your strategy. In the Strategy Tree, right-click the I/O unit containing the power monitoring module and choose Configure from the popup menu.

SNAP Power Monitoring Modules

2. Click the I/O points button. Double-click the module's position number on the rack. Click Analog Input and then choose the module's part number from the list. Click OK.
3. Click the plus sign next to the module to open its points.

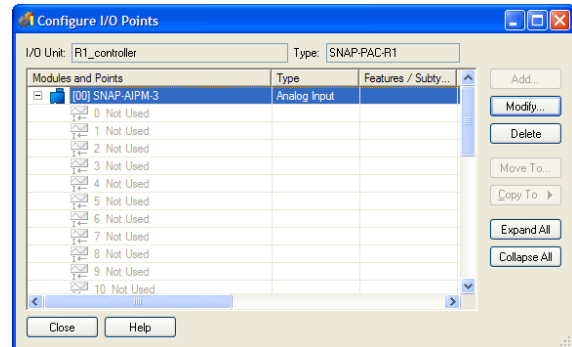

For the SNAP-AIPM, you see four points. For the SNAP-AIPM-3 (shown above) or the SNAP-AIPM-3V, you see 14. You must configure each point.

4. Double-click point 0, the voltage input, and give it a name. If you're not using a PT, leave the scaling as is. The following image illustrates point 0 for Scaling Example 3 on [page 8](#).

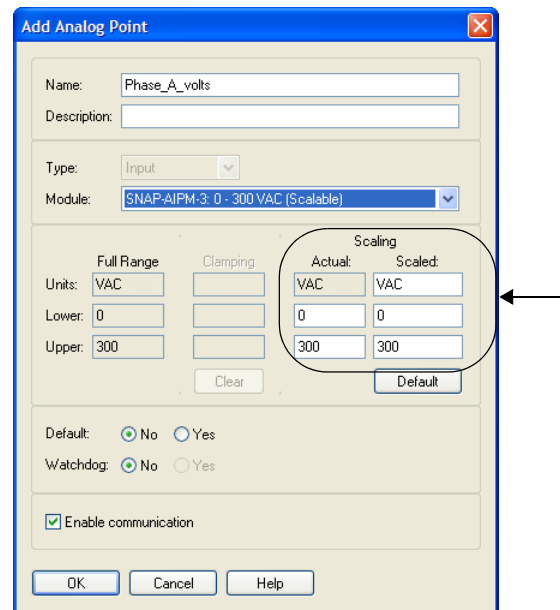

5. Click OK.
6. Continue to configure each point on the module, following the calculations in the examples:
SNAP-AIPM—[page 7](#)
SNAP-AIPM-3—[page 8](#)
SNAP-AIPM-3V—[page 9](#)

SNAP Power Monitoring Modules

7. Here is point 1 completed for Scaling Example 3:

Scaling Example 1: SNAP-AIPM without PT

Leave Actual values at their defaults for all points, and leave Lower Scaled values at 0. Calculate Upper Scaled values for points as follows:

Point 0: Always 250 volts for line voltage between 85 and 250 VAC. (For line voltage over 250 V, use Example 2.)

Point 1: 10^* (CT primary / CT secondary)

Point 2: Upper Scaled for pt 0 (voltage)* Upper Scaled for pt 1 (current)

Point 3: Upper Scaled for voltage * Upper Scaled for current

Example

Voltage: 240 VAC (no potential transformer required)

Current: 180 amps (requires CT primary of 200).

CT has a secondary of 5 A; the module accommodates 10 A.

So to calculate point 1: $10 * (200/5) = 400$

...points 2 and 3: $250 * 400 = 100,000$

	Voltage		Current	
	Point 0		Point 1	
	Actual	Scaled	Actual	Scaled
Units	VAC	VAC	A	A
Lower	0	0	0	0
Upper	250	250	10	400

	Watts		Volt Amps	
	Point 2		Point 3	
	Actual	Scaled	Actual	Scaled
Units	W	W	VA	VA
Lower	0	0	0	0
Upper	2500	100,000	2500	100,000

SNAP Power Monitoring Modules

Scaling Example 2: SNAP-AIPM with PT

For line voltage higher than 250 VAC, a step-down potential transformer (PT) must be used.

Leave Actual values at their defaults for all points, and leave Lower Scaled at 0. Calculate Upper Scaled values for points as follows:

Point 0: 250 * PT ratio

Point 1: 10* (CT primary / CT secondary)

Point 2: Upper Scaled for pt 0 (voltage)* Upper Scaled for pt 1 (current)

Point 3: Upper Scaled for voltage * Upper Scaled for current

Example

Voltage: 277 VAC (requires potential transformer).
PT ratio is 2:1

Current: 350 amps (Requires CT primary of 400. CT has a secondary of 5 A; the module accommodates 10 A.

So to calculate point 0: 250 * 2 = 500

...point 1: 10 * (400/5) = 800

...points 2 and 3: 500 * 800 = 400,000

Voltage			Current		
Point 0 (4, 8)			Point 1 (5, 9)		
	Actual	Scaled	Actual	Scaled	
Units	VAC	VAC	A	A	
Lower	0	0	0	0	
Upper	250	500	10	800	

Watts			Volt Amps		
Point 2 (6, 10)			Point 3 (7, 11)		
	Actual	Scaled	Actual	Scaled	
Units	W	W	VA	VA	
Lower	0	0	0	0	
Upper	2500	400,000	2500	400,000	

Scaling Example 3: SNAP-AIPM-3 without PT

Leave Actual values at their defaults for all points, and leave Lower Scaled values at 0. Calculate Upper Scaled values for points as follows:

Points 0, 4, 8: Always 300 volts¹ for line voltage between 85 and 300 VAC. (For line voltage over 300 V, use Example 2.)

Points 1, 5, 9: 5* (CT primary / CT secondary)

Points 2, 6, 10: Upper Scaled for voltage * Upper Scaled for current (ex. Upper Scaled for pt 0 * Upper Scaled for pt 1)

Points 3, 7, 11: Upper Scaled for voltage * Upper Scaled for current

Points 12, 13: 3 * Upper Scaled for voltage * Upper Scaled for current

Example

Voltage: 240 VAC (no potential transformer required)

Current: 180 amps (requires CT primary of 200).
CT has a secondary of 5 A.

So to calculate points 1, 5, 9: 5 * (200/5) = 200

...points 2, 6, 10, 3, 7, 11: 300 * 200 = 60,000

...points 12, 13: 3 * 300 * 200 = 180,000

Voltage			Current		
Points 0, 4, 8			Points 1, 5, 9		
	Actual	Scaled	Actual	Scaled	
Units	VAC	VAC	A	A	
Lower	0	0	0	0	
Upper	300	300	5	200	

Watts			Volt Amps		
Points 2, 6, 10			Points 3, 7, 11		
	Actual	Scaled	Actual	Scaled	
Units	W	W	VA	VA	
Lower	0	0	0	0	
Upper	1500	60,000	1500	60,000	

True Power & ABS		
Points 12 & 13		
	Actual	Scaled
Units	J	J
Lower	0	0
Upper	4500	180,000

1 IMPORTANT—Voltage change: Older SNAP-AIPM-3 modules used 0–250 volts and 0–10 amps. Before wiring or scaling, check the printed information on the module to make sure you are using the correct voltage and current. Contact Product Support to exchange older modules.

SNAP Power Monitoring Modules

Scaling Example 4: SNAP-AIPM-3 with PT

For line voltage higher than 300 VAC¹, a step-down potential transformer (PT) must be used.

Leave Actual values at their defaults for all points, and leave Lower Scaled at 0. Calculate Upper Scaled values for points as follows:

Points 0, 4, 8: $300 * PT \text{ ratio}$

Points 1, 5, 9: $5 * (CT \text{ primary} / CT \text{ secondary})$

Points 2, 6, 10: Upper Scaled for voltage * Upper Scaled for current (ex. Upper Scaled for pt 0 * Upper Scaled for pt 1)

Points 3, 7, 11: Upper Scaled for voltage * Upper Scaled for current

Points 12, 13: $3 * \text{Upper Scaled for voltage} * \text{Upper Scaled for current}$

Example

Voltage: 480 VAC (requires potential transformer).
PT ratio is 2:1

Current: 350 amps (Requires CT primary of 400. CT has a secondary of 5 A.

So to calculate points 0, 4, 8: $300 * 2 = 600$

...points 1, 5, 9: $5 * (400/5) = 400$

...points 2, 6, 10, 3, 7, 11: $600 * 400 = 240,000$

...points 12, 13: $3 * 600 * 400 = 720,000$

		Voltage		Current	
		Points 0, 4, 8		Points 1, 5, 9	
		Actual	Scaled	Actual	Scaled
Units		VAC	VAC	A	A
Lower		0	0	0	0
Upper		300	600	5	400

		Watts		Volt Amps	
		Points 2, 6, 10		Points 3, 7, 11	
		Actual	Scaled	Actual	Scaled
Units		W	W	VA	VA
Lower		0	0	0	0
Upper		1500	240,000	1500	240,000

		True Power & ABS	
		Points 12 & 13	
		Actual	Scaled
Units		J	J
Lower		0	0
Upper		4500	720,000

Scaling Example 5: SNAP-AIPM-3V without PT

The SNAP-AIPM-3V requires CTs with a 0.333 VAC secondary. (For suitable CTs, see Opto 22 form #1938, the [Split-Core Current Transformers Data Sheet](#).)

Leave Actual values at their defaults for all points, and leave Lower Scaled at 0. Calculate Upper Scaled as follows:

Points 0, 4, 8: Always 300 volts¹ for line voltage between 85 and 300 VAC. (For line voltage over 250 V, use Example 4.)

Points 1, 5, 9: Primary of the CT

Points 2, 6, 10: Upper Scaled for voltage * Upper Scaled for current (ex. Upper Scaled for pt 0 * Upper Scaled for pt 1)

Points 3, 7, 11: Upper Scaled for voltage * Upper Scaled for current

Points 12, 13: $3 * \text{Upper Scaled for voltage} * \text{Upper Scaled for current}$

Example

Voltage: 240 VAC (no potential transformer required)
Current: 100 amps (using a CT primary of 150)

So to calculate points 2, 6, 10, 3, 7, 11: $300 * 150 = 45,000$

...points 12, 13: $3 * 300 * 150 = 135,000$

		Voltage		Current	
		Points 0, 4, 8		Points 1, 5, 9	
		Actual	Scaled	Actual	Scaled
Unit		VAC	VAC	V	A
Lower		0	0	0	0
Upper		300	300	0.333	150

		Watts		Volt Amps	
		Points 2, 6, 10		Points 3, 7, 11	
		Actual	Scaled	Actual	Scaled
Unit			W		VA
Lower		0	0	0	0
Upper		1	45,000	1	45,000

		True Power & ABS	
		Points 12 & 13	
		Actual	Scaled
Unit			J
Lower		0	0
Upper		1	135,000

1 IMPORTANT—Voltage change: Older SNAP-AIPM-3V modules had an input range of 0–250 volts for points 0, 4, & 8. Before wiring or scaling, check the printed information on the module to make sure you are using the correct voltage. Contact Product Support to exchange older modules.

SNAP Power Monitoring Modules

Scaling Example 6: SNAP-AIPM-3V with PT

For line voltage higher than 300 VAC¹, a step-down potential transformer (PT) must be used.

The SNAP-AIPM-3V requires CTs with a 0.333 VAC secondary.

Leave Actual values at their defaults for all points, and leave Lower Scaled at 0. Calculate Upper Scaled as follows:

Points 0, 4, 8: $300 * PT$ ratio

Points 1, 5, 9: Primary of the CT

Points 2, 6, 10: Upper Scaled for voltage * Upper Scaled for current (ex. Upper Scaled for pt 0 * Upper Scaled for pt 1)

Points 3, 7, 11: Upper Scaled for voltage * Upper Scaled for current

Points 12, 13: $3 * \text{Upper Scaled for voltage} * \text{Upper Scaled for current}$

Example

Voltage: 480 VAC (requires potential transformer).
PT ratio is 2:1

Current: 350 amps (requires CT primary of 400)

So to calculate points 0, 4, 8: $300 * 2 = 600$

...points 2, 6, 10, 3, 7, 11: $600 * 400 = 240,000$

...points 12, 13: $3 * 600 * 400 = 720,000$

Voltage			Current		
Points 0, 4, 8			Points 1, 5, 9		
	Actual	Scaled	Actual	Scaled	
Unit	VAC	VAC	V	A	
Lower	0	0	0	0	
Upper	300	600	0.333	400	

Watts			Volt Amps		
Points 2, 6, 10			Points 3, 7, 11		
	Actual	Scaled	Actual	Scaled	
Unit		W		VA	
Lower	0	0	0	0	
Upper	1	240,000	1	240,000	

True Power & ABS		
Points 12 & 13		
	Actual	Scaled
Unit		J
Lower	0	0
Upper	1	720,000

SNAP Power Monitoring Modules

Wiring Diagrams—SNAP-AIPM

Single Phase Standard Wiring Diagram

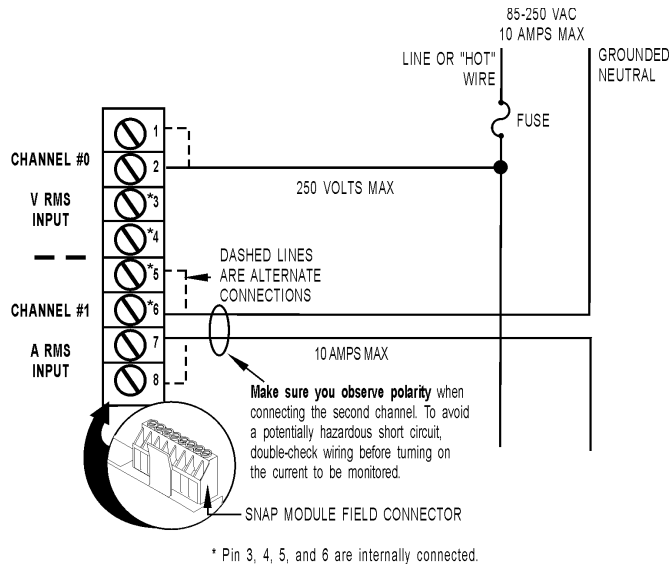

CAUTION: Be very careful when connecting input channels. **Do not connect line voltage to the current input channel;** such a connection will result in **severe damage** to the module. This damage is **not covered by warranty**.

CAUTION: Use caution when selecting wire gauges for your application. Use conservative wire gauges with proper voltage ratings.

CAUTION: Terminals 3, 4, 5, and 6 share a common connection inside the module.

CAUTION: The SNAP-AIPM module does not contain a fuse. Protect the system by adding a fuse. See below for a suggested vendor.

Suggested vendors

Protection fuses: <http://www.littelfuse.com>

Voltage and current transformers: <http://www.crmagnetics.com>

Measuring AC Line Current Greater Than 10 Amps with a Current Transformer

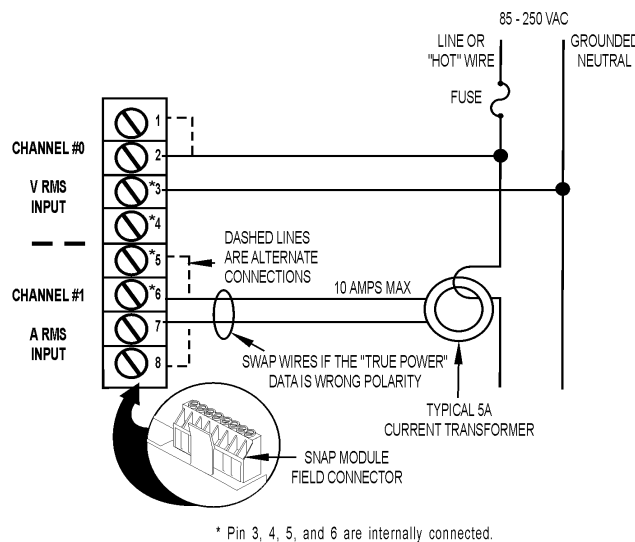

Measuring AC Voltage with a Voltage Transformer and a Current Transformer

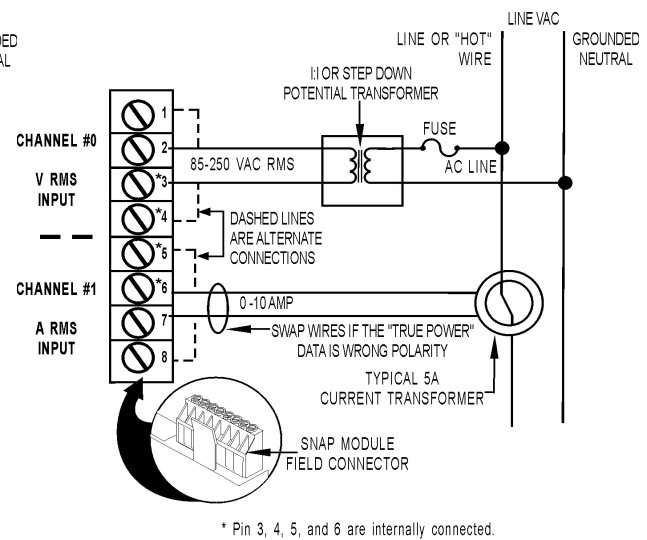

SNAP Power Monitoring Modules

Wiring Diagrams—SNAP-AIPM (continued)

Three-Phase Wiring to Three SNAP-AIPM Modules

See cautions on [page 11](#). If you have a SNAP-AIPM-3 module, see [page 14](#). For a SNAP-AIPM-3V, see [page 16](#).

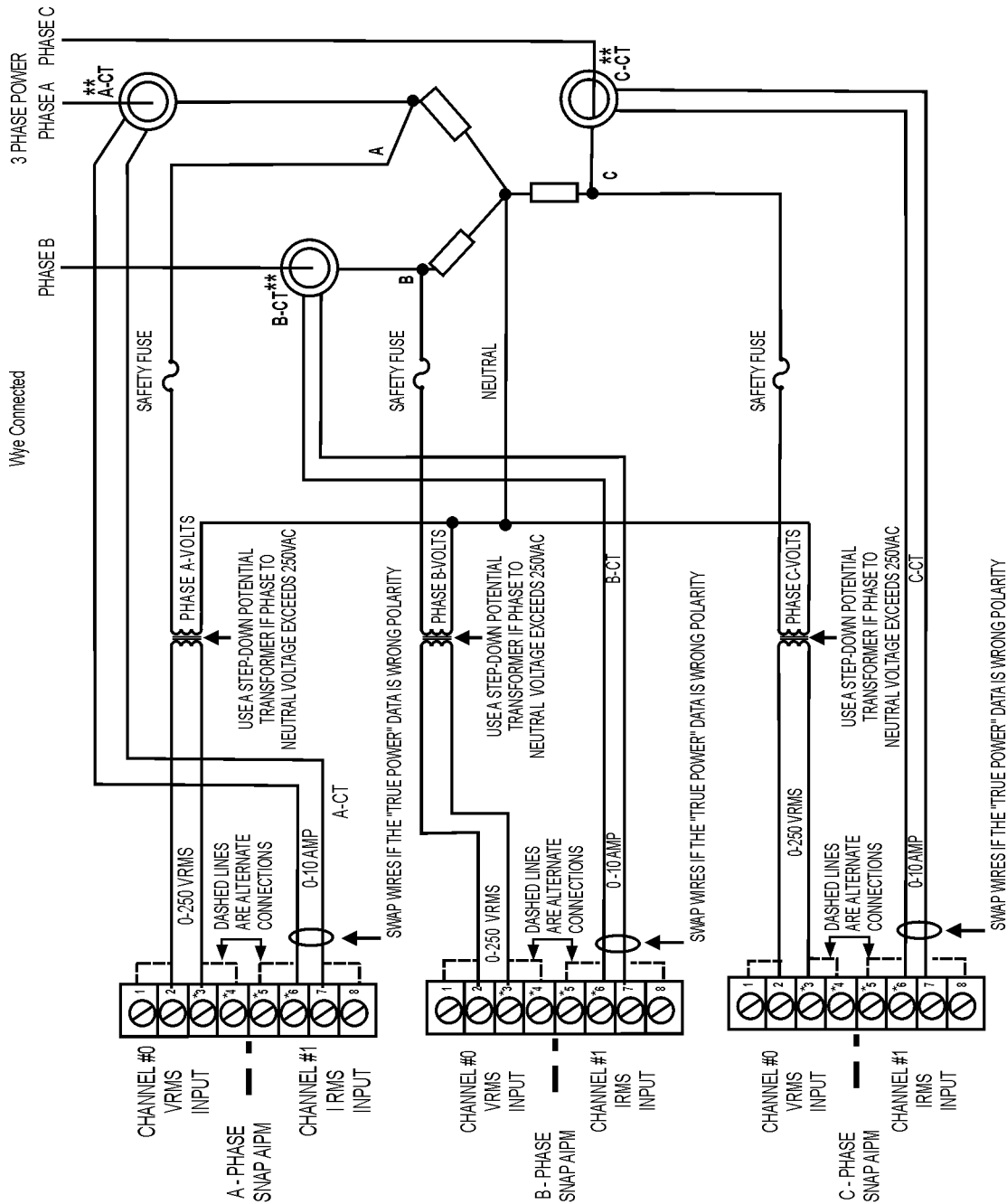

** Typical 5A current transformer

*Pins 3, 4, 5, and 6 are internally connected

SNAP Power Monitoring Modules

Wiring Diagrams—SNAP-AIPM (continued)

Three-Phase Wiring to Two SNAP-AIPM Modules

See cautions on [page 11](#). If you have a SNAP-AIPM-3 module, see [page 15](#). For a SNAP-AIPM-3V, see [page 16](#).

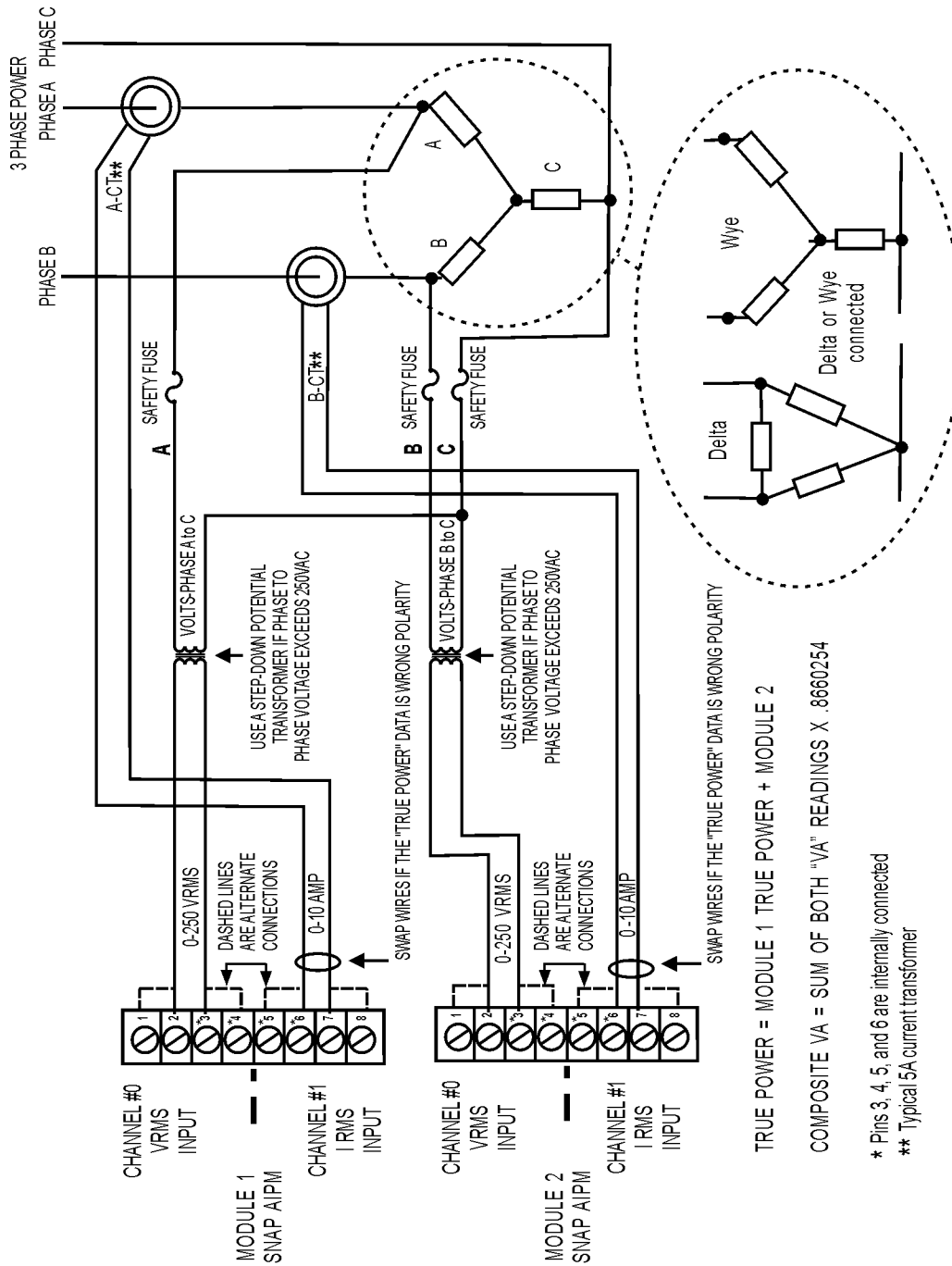

NOTE: Three-phase wiring to two modules is used when the neutral of a wye 3-phase is *not* available.

SNAP Power Monitoring Modules

Wiring Diagrams—SNAP-AIPM-3

Three-Phase Wiring to SNAP-AIPM-3 Module

CAUTION: Be very careful when connecting input channels. **Do not connect line voltage to the current input channel;** such a connection will cause **severe damage** to the module. This damage is **not covered by warranty**. Use a current transformer instead.

CAUTION: Terminals 2 and 3 share a common connection inside the module. **Make sure you observe polarity** when connecting the second channel. To avoid a potentially hazardous short circuit, double-check wiring before turning on the current to be monitored.

CAUTION: Use caution when selecting wire gauges for your application. Use conservative wire gauges with proper voltage ratings.

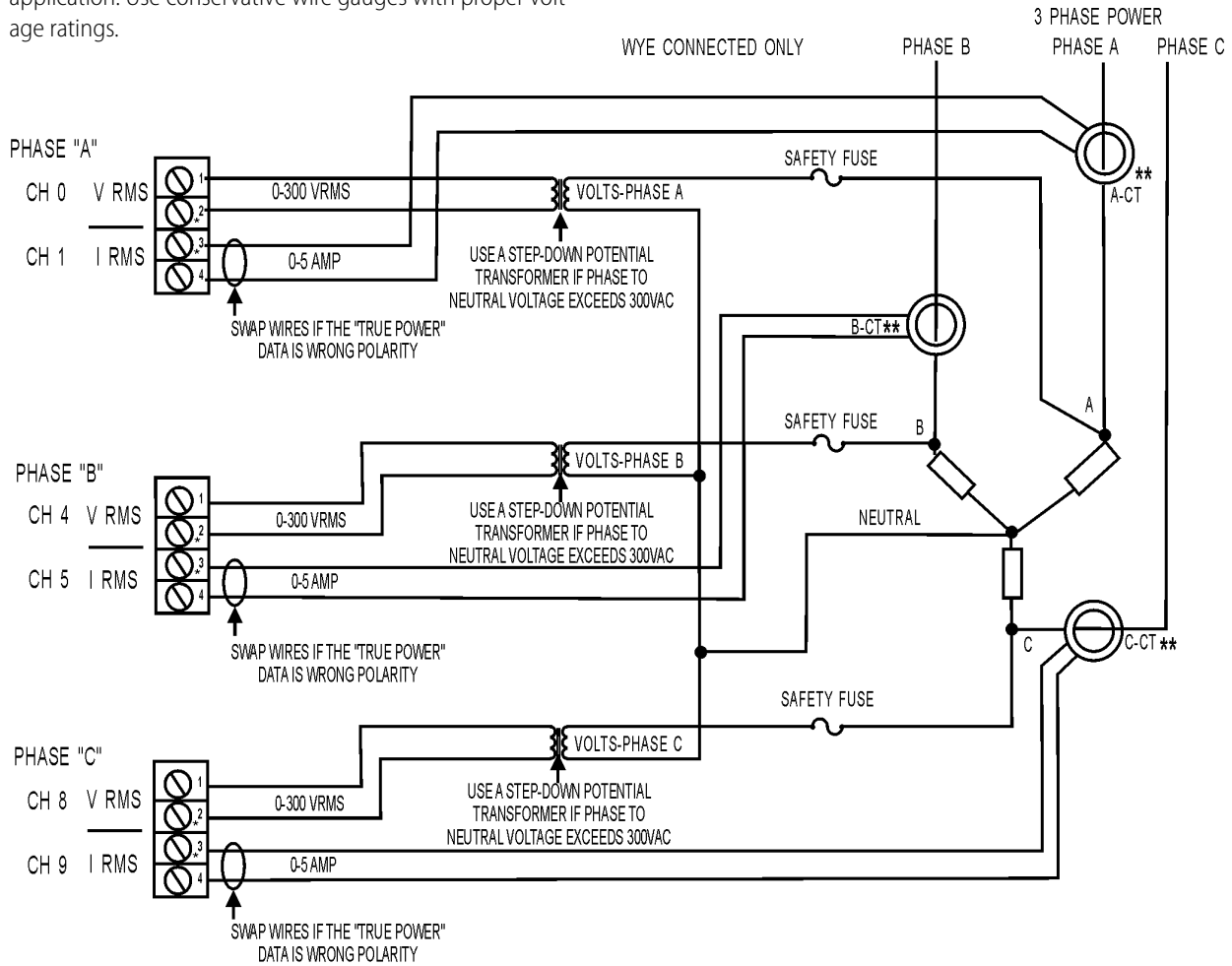

* Pins 2+3 are internally connected

** Typically a 5A current transformer is used.

Using this wiring, after you scale the module, the following measurements are available. All measurements are synchronously updated every second:

- | | |
|--|--|
| <ul style="list-style-type: none"> • Individual phase to neutral voltage • Individual phase and load current • Individual phase power • Individual phase volt-amps | <ul style="list-style-type: none"> • 3-phase sum of 1 sec.—signed energy (watt seconds) • 3-phase sum of 1 sec.—unsigned energy (watt sec) |
|--|--|

IMPORTANT—Voltage change: Older SNAP-AIPM-3 modules used 0–250 volts and 0–10 amps. Before wiring or scaling, check the printed information on the module to make sure you are using the correct voltage and current.

CAUTION: The SNAP-AIPM-3 module does not contain a fuse. Protect the system by adding a fuse.

Suggested vendors

Protection fuses:
<http://www.littelfuse.com>
 Voltage and current transformers:
<http://www.crmagnetics.com>

SNAP Power Monitoring Modules

Wiring Diagrams—SNAP-AIPM-3

Three-Phase Wiring to SNAP-AIPM-3 Module

NOTE: This wiring method is less expensive than the one on page 14 but does not provide as much information.

CAUTION: Be very careful when connecting input channels. **Do not connect line voltage to the current input channel;** such a connection will result in **severe damage** to the module. This damage is **not covered by warranty**. Use a current transformer instead.

CAUTION: Use caution when selecting wire gauges for your application. Use conservative wire gauges with proper voltage ratings.

CAUTION: Terminals 2 and 3 share a common connection inside the module. **Make sure you observe polarity** when connecting the second channel. To avoid a potentially hazardous short circuit, double-check wiring before turning on the current to be monitored.

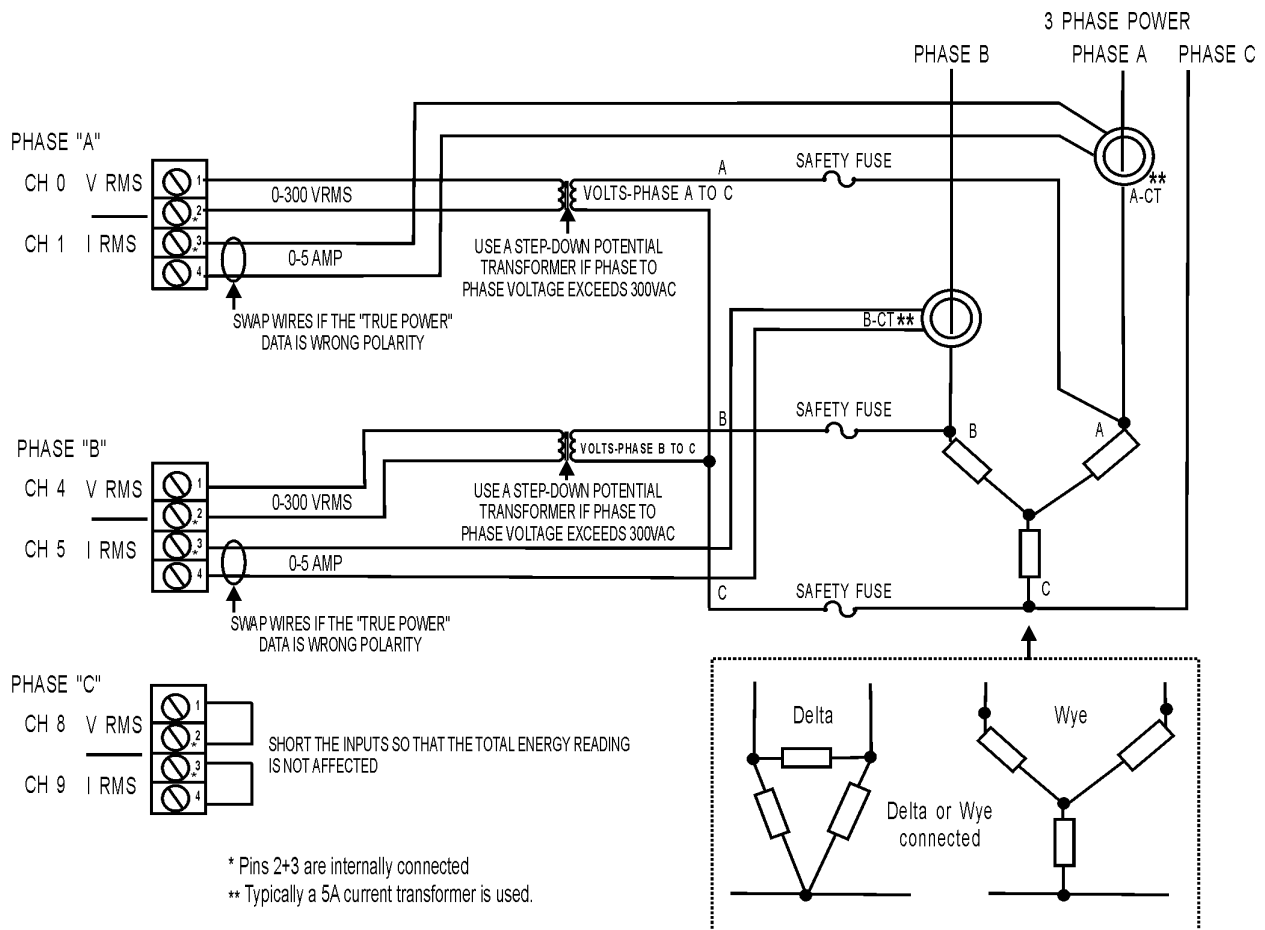

Using this wiring, after you scale the module, the following measurements are available. All measurements are synchronously updated every second:

- Volts, phase A to phase C
- Volts, phase B to phase C
- 3-phase sum of 1 sec.—signed energy (watt seconds)
- 3-phase sum of 1 sec.—unsigned energy (watt secs)

IMPORTANT—Voltage change: Older SNAP-AIPM-3 modules used 0–250 volts and 0–10 amps. Before wiring or scaling, check the printed information on the module to make sure you are using the correct voltage and current.

CAUTION: The SNAP-AIPM-3 module does not contain a fuse. Protect the system by adding a fuse.

Suggested vendors
 Protection fuses:
<http://www.littelfuse.com>
 Voltage and current transformers:
<http://www.crmagnetics.com>

SNAP Power Monitoring Modules

Wiring Diagrams—SNAP-AIPM-3V

Three-Phase Wiring to SNAP-AIPM-3V Module

CAUTION: Be very careful when connecting input channels. **Do not connect line voltage to the current input channel;** such a connection will cause **severe damage** to the module. This damage is **not covered by warranty**. Use a current transformer instead. Use identical CTs on all phases.

CAUTION: Use caution when selecting wire gauges for your application. Use conservative wire gauges with proper voltage ratings.

CAUTION: Terminals 2 and 3 share a common connection inside the module. **Make sure you observe polarity** when connecting the second channel. To avoid a potentially hazardous short circuit, double-check wiring before turning on the current to be monitored.

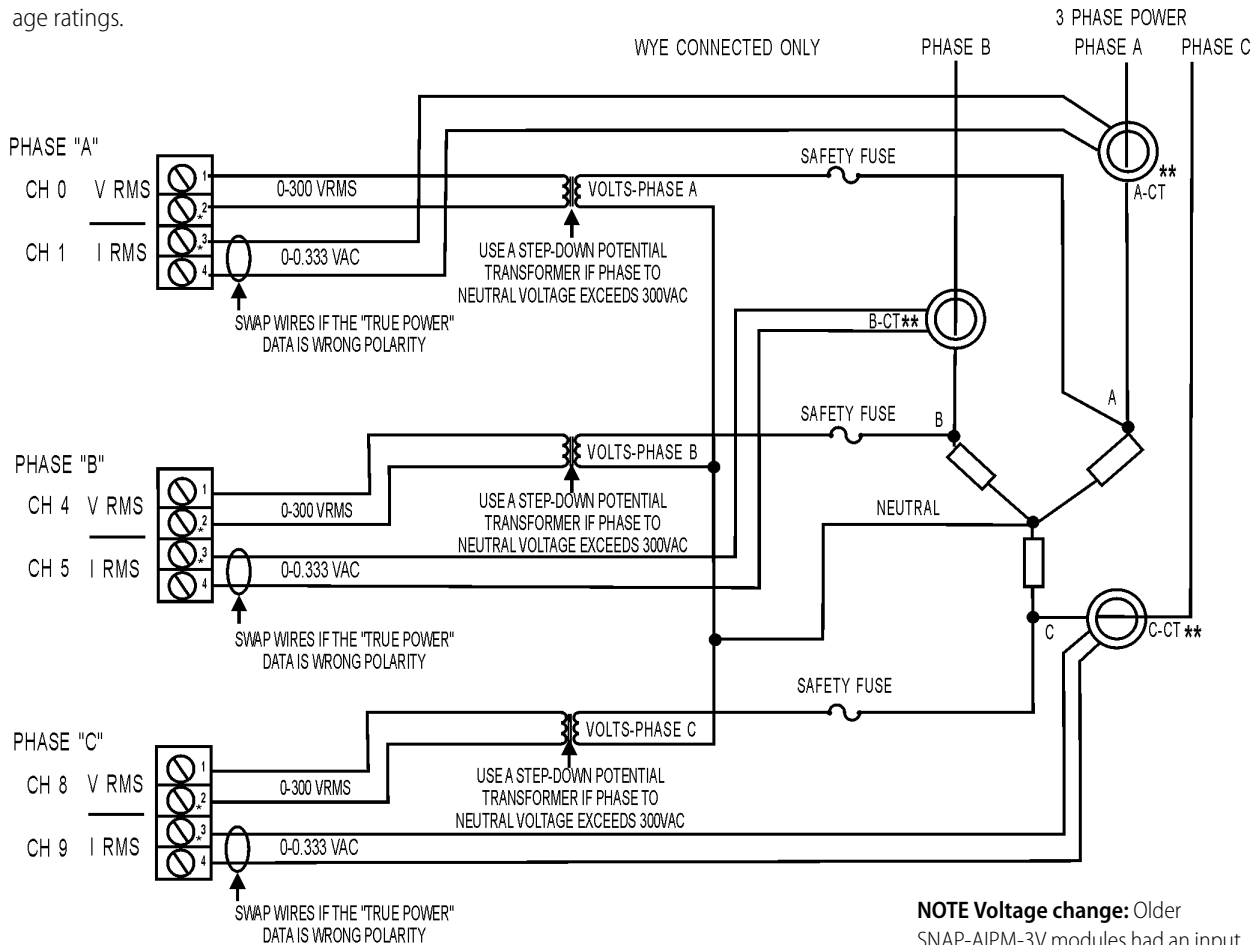

* Pins 2+3 are internally connected ** 0.333 VAC current transformer

NOTE Voltage change: Older SNAP-AIPM-3V modules had an input range of 0–250 volts. Before wiring, check printed specs on the module.

Using this wiring, after you scale the module, the following measurements are available. All measurements are synchronously updated every second:

- | | |
|--|--|
| <ul style="list-style-type: none"> • Individual phase to neutral voltage • Individual phase and load current • Individual phase power • Individual phase volt-amps | <ul style="list-style-type: none"> • 3-phase sum of 1 sec.—signed energy (watt seconds) • 3-phase sum of 1 sec.—unsigned energy (watt sec) |
|--|--|

CAUTION: The SNAP-AIPM-3V module does not contain a fuse. Protect the system by adding a fuse.

Suggested vendors
 Protection fuses:
<http://www.littelfuse.com>
 Voltage and current transformers:
<http://www.crmagnetics.com>

Suitable **current transformers (CTs)** for use with the SNAP-AIPM-3V are available from Opto 22. See form #1938, the [Split-Core Current Transformers Data Sheet](#).

SNAP Power Monitoring Modules

Wiring Diagrams—SNAP-AIPM-3V

Three-Phase Wiring to SNAP-AIPM-3V Module

NOTE: This wiring method is less expensive than the one on page 14 but does not provide as much information.

CAUTION: Be very careful when connecting input channels. **Do not connect line voltage to the current input channel;** such a connection will result in **severe damage** to the module. This damage is **not covered by warranty**. Use a current transformer instead. Identical CTs must be used on all phases.

CAUTION: Use caution when selecting wire gauges for your application. Use conservative wire gauges with proper voltage ratings.

CAUTION: Terminals 2 and 3 share a common connection inside the module. **Make sure you observe polarity** when connecting the second channel. To avoid a potentially hazardous short circuit, double-check wiring before turning on the current to be monitored.

NOTE Voltage change: Older SNAP-AIPM-3 modules had an input range of 0–250 volts. Before wiring, check printed specs on the module.

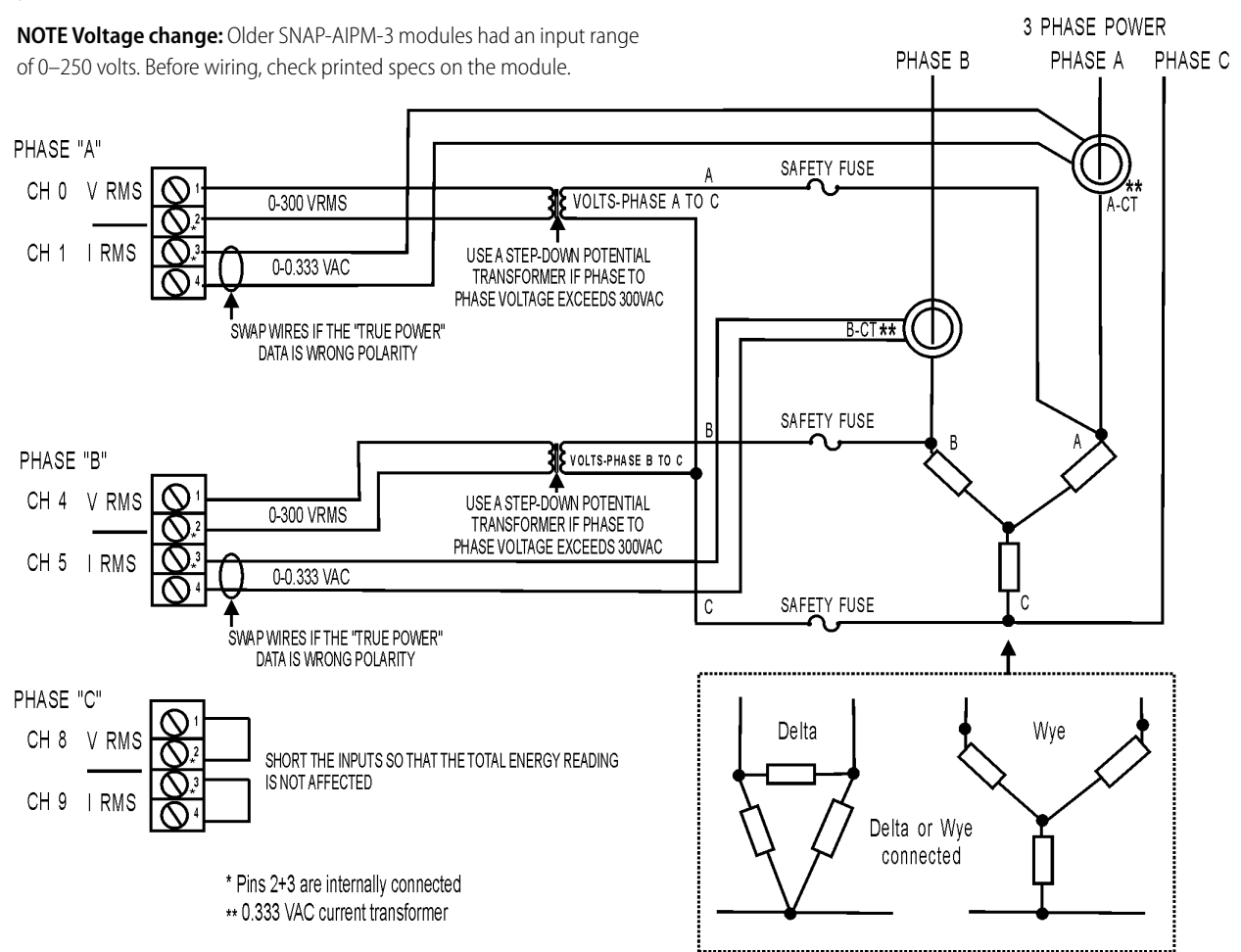

Using this wiring, after you scale the module, the following measurements are available. All measurements are synchronously updated every second:

• Volts, phase A to phase C	• 3-phase sum of 1 sec.—signed energy (watt seconds)
• Volts, phase B to phase C	• 3-phase sum of 1 sec.—unsigned energy (watt secs)

Suitable **current transformers (CTs)** for use with the SNAP-AIPM-3V are available from Opto 22. See form #1938, the [Split-Core Current Transformers Data Sheet](#), for more information.

CAUTION: The SNAP-AIPM-3V module does not contain a fuse. Protect the system by adding a fuse.

Suggested vendors
 Protection fuses:
<http://www.littelfuse.com>
 Voltage and current transformers:
<http://www.crmagnetics.com>

SNAP Power Monitoring Modules

Dimensional Drawing—SNAP-AIPM

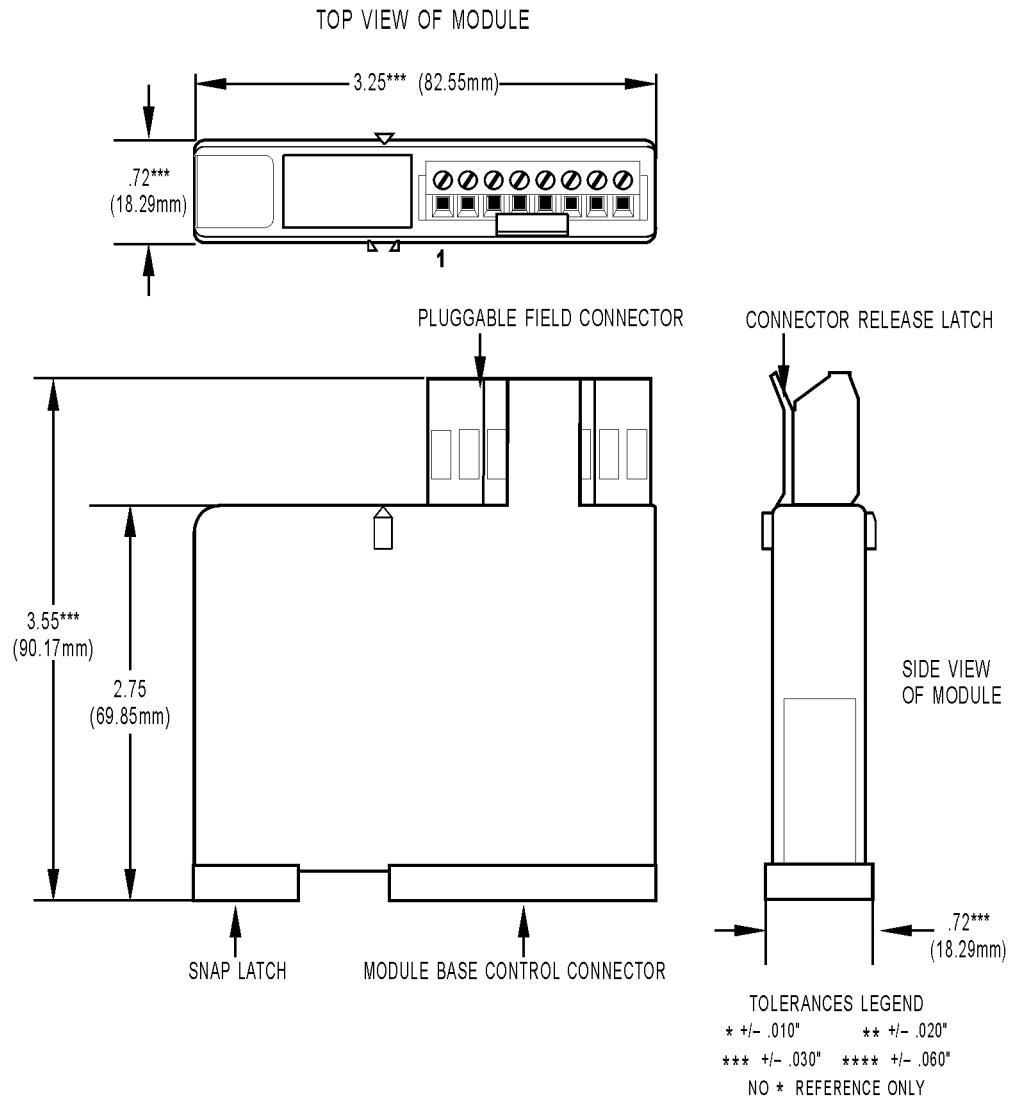

SNAP Power Monitoring Modules

Dimensional Drawing—SNAP-AIPM-3 and SNAP-AIPM-3V

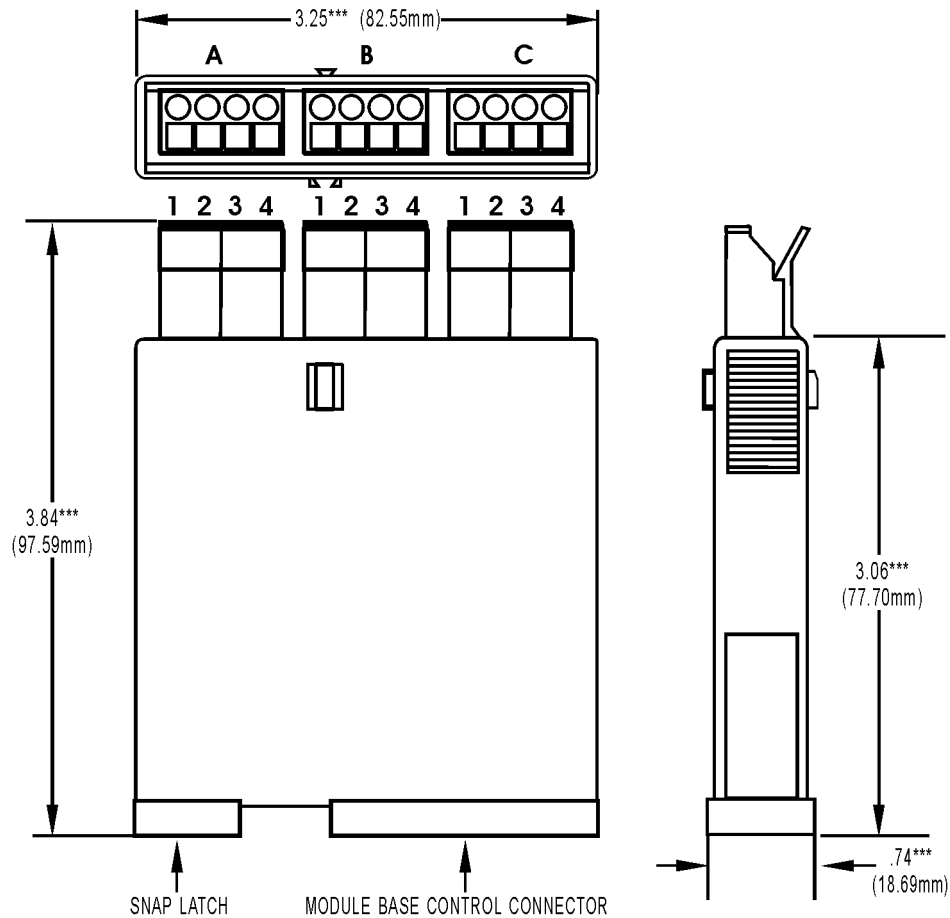

TOLERANCES LEGEND
 * +/- .010" ** +/- .020"
 *** +/- .030" **** +/- .060"
 NO * REFERENCE ONLY

SNAP Power Monitoring Modules

Dimensional Drawing—All AIPM Modules

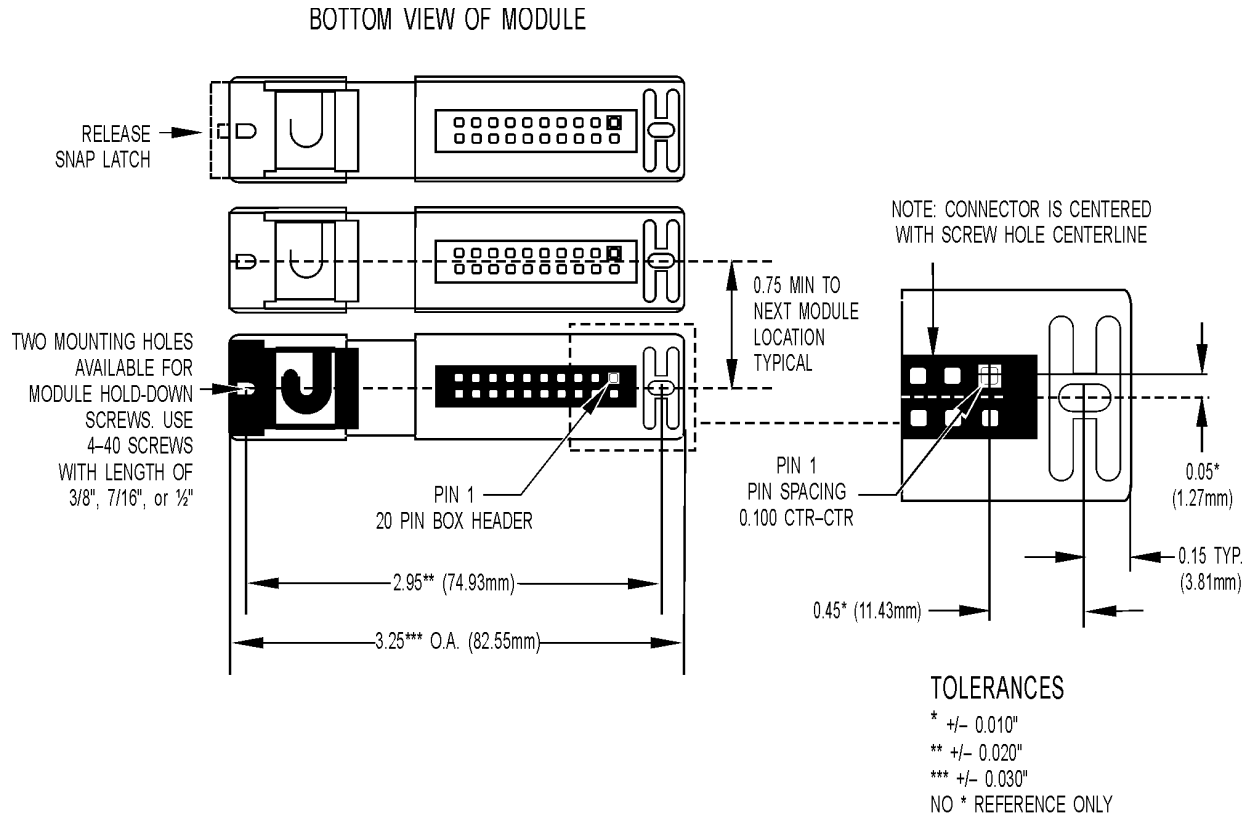

IMPORTANT: The mounting rack connector has 24 pins; the module connector has 20 pins. The extra pins on the mounting rack connector prevent misalignment of the module during installation.

SNAP Power Monitoring Modules

Dimensional Drawing—All AIPM Modules

NOTE: The SNAP-AIPM-3 and SNAP-AIPM-3V have three connectors on the top of the case, at the same height as shown below.

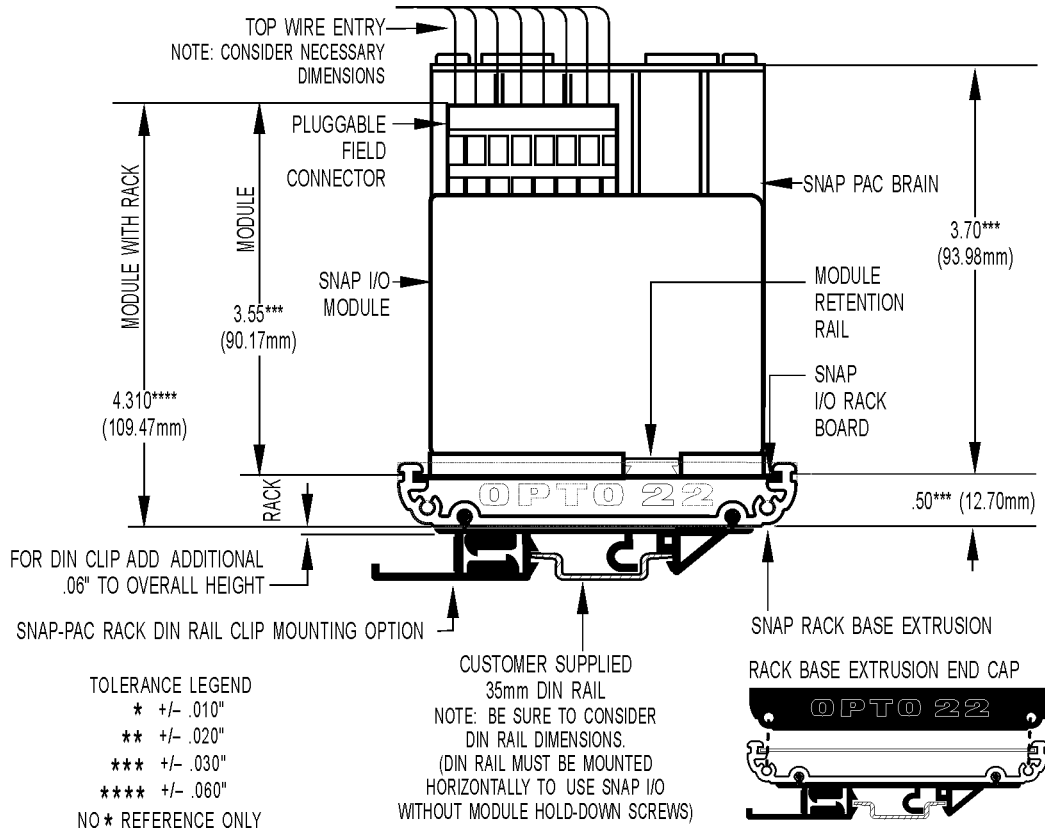

More About Opto 22

Products

Opto 22 develops and manufactures reliable, flexible, easy-to-use hardware and software products for industrial automation, energy management, remote monitoring, and data acquisition applications.

groov

groov puts your system on your mobile device. With zero programming, you can build mobile operator interfaces to monitor and control systems from Allen-Bradley, Siemens, Schneider Electric, Modicon, and many more. Web-based groov puts mobile-ready gadgets at your fingertips. Tag them from your existing tag database, and they automatically scale for use on any device with a modern web browser. See groov.com for more information and your free trial.

SNAP PAC System

Designed to simplify the typically complex process of selecting and applying an automation system, the SNAP PAC System consists of four integrated components:

- SNAP PAC controllers
- PAC Project™ Software Suite
- SNAP PAC brains
- SNAP I/O™

SNAP PAC Controllers

Programmable automation controllers (PACs) are multifunctional, modular controllers based on open standards.

Opto 22 has been manufacturing PACs for over two decades. The standalone SNAP PAC S-series, the rack-mounted SNAP PAC R-series, and the software-based SoftPAC™ all handle a wide range of digital, analog, and serial functions for data collection, remote monitoring, process control, and discrete and hybrid manufacturing.

SNAP PACs are based on open Ethernet and Internet Protocol (IP) standards, so you can build or extend a system easily, without the expense and limitations of proprietary networks and protocols. Wired+Wireless™ models are also available.

PAC Project Software Suite

Opto 22's PAC Project Software Suite provides full-featured, cost-effective control programming, HMI (human machine interface) development and runtime, OPC server, and database connectivity software for your SNAP PAC System.

Control programming includes both easy-to-learn flowcharts and optional scripting. Commands are in plain English; variables and I/O point names are fully descriptive.

PAC Project Basic offers control and HMI tools and is free for download on our website, www.opto22.com. PAC Project

Professional, available for separate purchase, adds one SoftPAC, OptoOPCServer, OptoDataLink, options for controller redundancy or segmented networking, and support for legacy Opto 22 serial *mistic*™ I/O units.

SNAP PAC Brains

While SNAP PAC controllers provide central control and data distribution, SNAP PAC brains provide distributed intelligence for I/O processing and communications. Brains offer analog, digital, and serial functions, including thermocouple linearization; PID loop control; and optional high-speed digital counting (up to 20 kHz), quadrature counting, TPO, and pulse generation and measurement.

SNAP I/O

I/O provides the local connection to sensors and equipment. Opto 22 SNAP I/O offers 1 to 32 points of reliable I/O per module, depending on the type of module and your needs. Analog, digital, and serial modules are all mixed on the same mounting rack and controlled by the same processor (SNAP PAC brain or rack-mounted controller).

Quality

Founded in 1974, Opto 22 has established a worldwide reputation for high-quality products. All are made in the U.S.A. at our manufacturing facility in Temecula, California. Because we test each product twice before it leaves our factory, rather than only testing a sample of each batch, we can guarantee most solid-state relays and optically isolated I/O modules for life.

Free Product Support

Opto 22's California-based Product Support Group offers free, comprehensive technical support for Opto 22 products. Our staff of support engineers represents decades of training and experience. Support is available in English and Spanish by phone or email, Monday–Friday, 7 a.m. to 5 p.m. PST.

Additional support is always available on our website: how-to videos, OptoKnowledgeBase, self-training guide, troubleshooting and user's guides, and OptoForums.

In addition, hands-on training is available for free at our Temecula, California headquarters, and you can [register online](#).

Purchasing Opto 22 Products

Opto 22 products are sold directly and through a worldwide network of distributors, partners, and system integrators. For more information, contact Opto 22 headquarters at 800-321-6786 or 951-695-3000, or visit our website at www.opto22.com.



www.opto22.com