

# Tooling



## Crimptooling for Size 16 contacts (Ø 1,6 mm)

For an overview on crimping refer to "crimping tables" at the different contact sections.



### Y14SCM2 - for formed contacts

A low cost non ratchet plier type handtool for AWG26 to 16 + insulation crimp for:

**Size 16 TRIM TRIO SM-M/SC-M loose piece formed contacts.**  
**Size 20 SEALOK SM-W/SC-W loose piece formed contacts.**



### M8ND - for machined and formed contacts

A robust full cycling hand ratchet tool which utilises interchangeable "N" die sets to crimp

**Size 16 TRIM TRIO RM/RC loose piece machined contacts.**  
**Size 16 TRIM TRIO SM-M/SC-M loose piece formed contacts.**

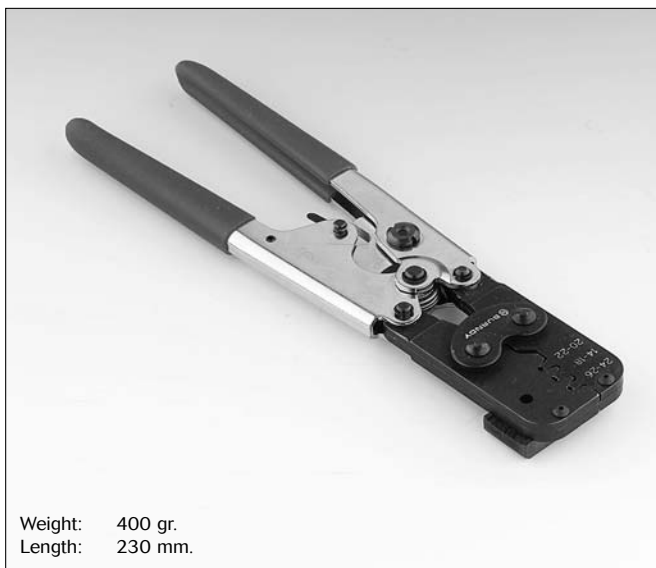

### Y14MTV - for formed contact

A light weight crimping tool with fixed 3-groove die set for AWG26 to 14 for: **Size 16 TRIM TRIO SM-M/SC-M loose piece formed contacts.**

Ratchet controlled to guarantee a complete crimp cycle.

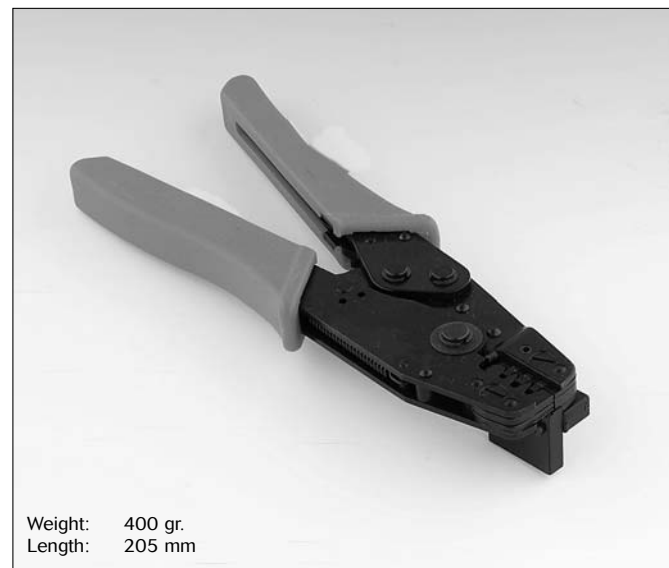

### Y16SCM2 - for formed contacts

A light weight crimping tool with fixed 3-groove die set for AWG26 to 16 for:

**Size 16 TRIM TRIO SM-M/SC-M loose piece formed contacts.**

Ratchet controlled to guarantee a complete crimp cycle. Each crimping tool is supplied with a locator to guarantee a perfect crimp indent positioning.

# Tooling



## Crimptooling for Size 20 contacts (Ø 1,0 mm)

For an overview on crimping refer to "crimping tables" at the different contact sections.



Weight: 300 gr.  
Length: 170 mm.

### MH860 - for machined contacts

A light weight crimping tool Qualified to MIL-C-22520/7 that gives an 8 impression crimp with a precision cycle-controlled ratcheting mechanism. It features an 8 step crimp-depth selector knob. The tool can be provided with different locator heads to crimp different contact types.



Weight: 340 gr.  
Length: 220 mm

### Y14SCM2 - for formed contacts

A low cost non ratchet plier type handtool for AWG26 to 16 + insulation crimp.

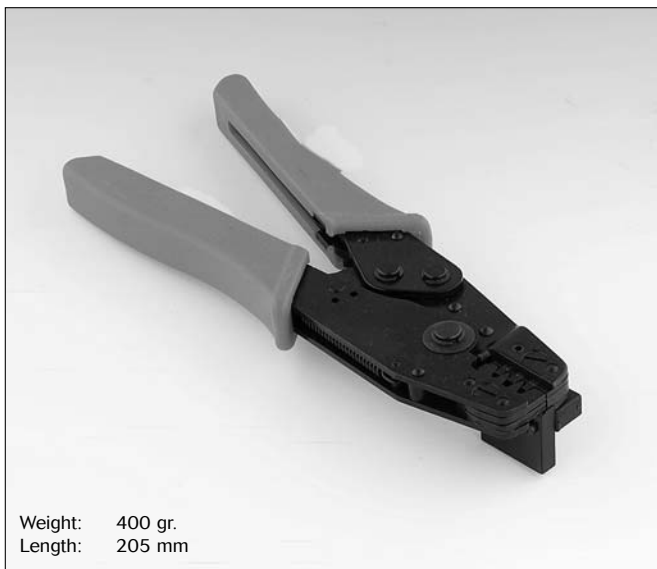

Weight: 400 gr.  
Length: 205 mm

### Y16SCM3 - for formed contacts

A light weight crimping tool with fixed 3-groove die set for AWG26 to 16 for:

#### Size 20 loose piece formed contacts.

Ratchet controlled to guarantee a complete crimp cycle.  
Each crimping tool is supplied with a locator to guarantee a perfect crimp indent positioning.



Weight: 400 gr.  
Length: 230 mm.

### Y14MTV - for formed contact

A light weight crimping tool with fixed 3-groove die set for AWG26 to 14. Ratchet controlled to guarantee a complete crimp cycle.

# Tooling



## Extraction and insertion tooling for size 20 contacts (Ø 1,0 mm)



### **RX20D44**

A spring loaded extraction tool. This tool ensures that the contact locking louvres are fully retracted before any pressure is applied to extract a contact. It is especially suitable for applications where the integrity of the assemblies are of the utmost importance.

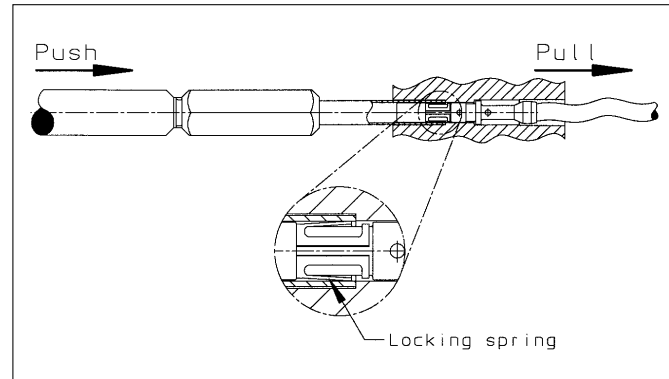

### **How to extract a contact out of its cavity?**

Slide the extraction tip over contact from mating side till the locking spring from the contact is depressed. Push on handle to push out the contact with the spring loaded inner plunger.

## Insertion tooling



### **RTM205**

This tool is especially designed to ease insertion **of any contact** crimped on very flexible or small wire sizes. Simply position the insertion tool so that the tip of the tool bears against the back of the wire barrel, retaining the wire with thumb in the groove of the tool. Push the contact slowly into the connector until it snaps into position.