

We Tame Photons to Work for You!

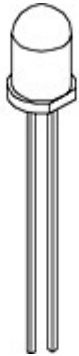

Products > LEDs > Thru-Hole > Round > 5mm > Standard > High Intensity



Features / Options

- ▶ State-of-the-Art, High Brightness Chip Technology
- ▶ Choice of Colors and Lens Finishes
- ▶ Lead Frame / Lens Casting Reliability
- ▶ Easy-to-Solder Leads, Tin Finish
- ▶ Available Bulk or on Tape and Reel
- ▶ Lead Trimming and Forming Available
- ▶ Custom Shapes, Easily Tooled, Low Minimum

Applications / Uses

- ▶ Board or Panel Indication or Illumination
- ▶ Annunciator and Control Panels
- ▶ Telecom Switches and Central Station Equipment
- ▶ Large Panel Indicators

Part Number:	Brightness	Dice Material	Emitted Color	Peak Wavelength	Epoxy Lens	Operating Typ Vf (V)	Intensity Typ, mcd @ 20 mA	View Angle 2x Theta		
SSL-LX5093PC	HIGH	InGaN	Pink	-	Clear	3.5	2200	20		—
SSL-LX5093PGD	STANDARD	GaP	Green	555	Diffused	2.1	30	60		—
SSL-LX5093PGT	STANDARD	GaP	Green	555	Color Tinted	2.0	50	30		—
SSL-LX5093SIC	HIGH	AllnGaP	Red	636	Clear	2.0	1800	30		—
SSL-LX5093SID	HIGH	AllnGaP	Red	636	Diffused	2.0	700	60		—
SSL-LX5093SOC	HIGH	AllnGaP	Orange	610	Clear	2.0	2500	30		—
SSL-LX5093SOD	HIGH	AllnGaP	Orange	610	Diffused	2.0	850	60		—
SSL-LX5093SRC/DU	STANDARD	GaAlAs	Red	660	Clear	1.7	1300	30		—
SSL-LX5093SRC/DV	STANDARD	GaAlAs	Red	660	Clear	1.7	1600	30		—
SSL-LX5093SRC/DW	STANDARD	GaAlAs	Red	660	Clear	1.7	2000	30		—

UNCONTROLLED DOCUMENT

PART NUMBER
SSL-LX5093SID

REV.
A

REV.	E.C.N. NUMBER AND REVISION COMMENTS	DATE
A	E.C.N. #11148	10.24.06

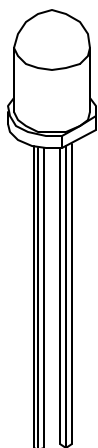
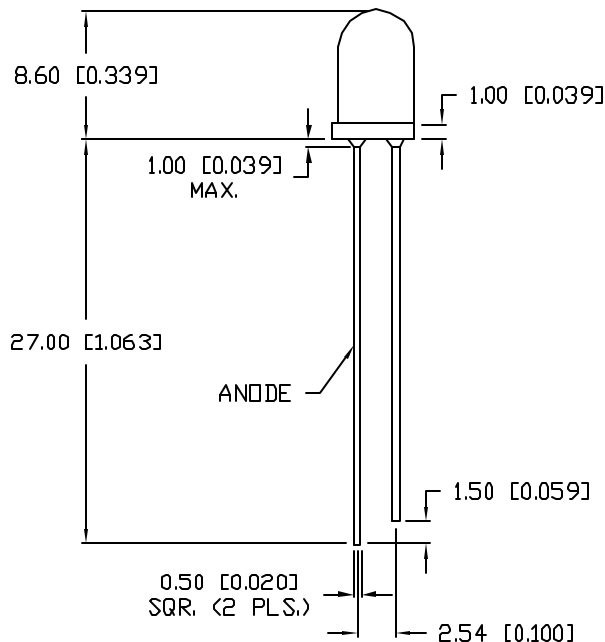
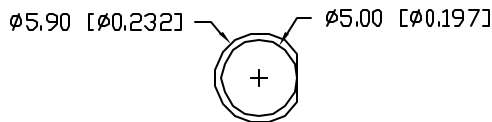

ELECTRO-OPTICAL CHARACTERISTICS $T_A=25^{\circ}\text{C}$ $I_f=20\text{mA}$

PARAMETER	MIN	TYP	MAX	UNITS	TEST COND
PEAK WAVELENGTH		636		nm	
FORWARD VOLTAGE		2.0	2.5	V_f	
REVERSE VOLTAGE	5.0			V_r	$I_r=100\mu\text{A}$
AXIAL INTENSITY		700		med	$I_f=20\text{mA}$
VIEWING ANGLE		60		$2x$ theta	
EMITTED COLOR:	RED				
EPOXY LENS FINISH:	RED DIFFUSED				

LIMITS OF SAFE OPERATION AT 25°C

PARAMETER	MAX	UNITS
PEAK FORWARD CURRENT*	150	mA
STEADY CURRENT	30	mA
POWER DISSIPATION	105	mW
DERATE FROM 25°C	-1.2	mW/ $^{\circ}\text{C}$
OPERATING, STORAGE TEMP.	-40 TO +85	$^{\circ}\text{C}$
SOLDERING TEMP.	+260	$^{\circ}\text{C}$
2.0mm FROM BODY		3 SEC. MAX
* $t < 10\mu\text{s}$		



UNCONTROLLED DOCUMENT

*UNLESS OTHERWISE SPECIFIED TOLERANCES PER DECIMAL PRECISION ARE: X=±1 (±0.039), XX=±0.5 (±0.020), XXX=±0.25 (±0.010), XXXX=±0.127 (±0.005). LEAD SIZE=±0.05 (±0.002), LEAD LENGTH=±0.75 (±0.030). MIN= ^{+0.00} -0.00 DECIMAL PRECISION MAX.= ^{+0.00} -0.00 DECIMAL PRECISION

REV. A	PART NUMBER SSL-LX5093SID	CONFIDENTIAL INFORMATION THE INFORMATION CONTAINED IN THIS DOCUMENT IS THE PROPERTY OF LUMEX INC. EXCEPT AS SPECIFICALLY AUTHORIZED IN WRITING BY LUMEX INC., THE HOLDER OF THIS DOCUMENT SHALL KEEP ALL INFORMATION CONTAINED HEREIN CONFIDENTIAL AND SHALL PROTECT SAME IN WHOLE OR IN PART FROM DISCLOSURE AND DISSEMINATION TO ALL THIRD PARTIES.	
T-5mm 636nm SUPER HIGH INTENSITY RED LED, RED DIFFUSED LENS.		RELIABILITY NOTE OUR MANY YEARS OF EXPERIENCE DATA ACCUMULATION INDICATE THAT SOLDER HEAT IS A MAJOR CAUSE OF EARLY AND FUTURE FAILURE. PLEASE PAY ATTENTION TO YOUR SOLDERING PROCESS.	DRAWN BY: JC CHECKED BY: APPROVED BY: DATE: 10.24.06 PAGE: 1 OF 1 SCALE: N/A