

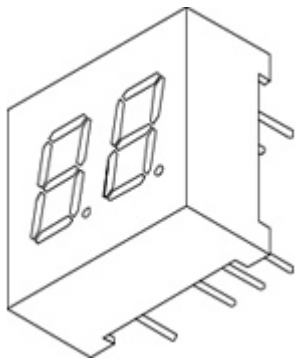

We Tame Photons to Work for You!



Products > LED Displays > Thru-Hole > Numeric > Dual Digit > Right Angle > .30"



Features / Options

- ▶ Standard and high brightness chips
- ▶ Intensity grading available
- ▶ Custom Sizes at minimal tooling
- ▶ Face and segment off colors in grey and milky white
- ▶ Standard and High Brightness Chips
- ▶ Intensity Grading Available
- ▶ Custom Sizes Available
- ▶ Face and segment off colors in gray and milky white

Applications / Uses

- ▶ Instrument Panels
- ▶ Medical Diagnostics
- ▶ Test Equipment
- ▶ Control Panels

Part Number:	Wavelength	Intensity mcd @ 10mA	Color	Common Pin	Face	Segment		
LDD-E302NI	565	3000	Green	(+)	Grey	White		—
LDD-E302NI-SUG	574	7000	Green	(+)	Grey	White		—
LDD-E303NI	585	3000	Yellow	(+)	Grey	White		—
LDD-E304NI	625	5000	Red	(+)	Grey	White		—
LDD-E304NI-SI	636	15000	Red	(+)	Grey	White		—
LDD-E306NI	660	9000	Unable to look up Color	(+)	Grey	White		—
LDD-E307NI-USB	470	6000	Blue	(+)	Grey	White		—
LDD-F302NI	565	3000	Green	(-)	Grey	White		—
LDD-F302NI-SUG	574	7000	Green	(-)	Grey	White		—
LDD-F303NI	585	3000	Yellow	(-)	Grey	White		—

LDD-F304NI		625	5000	Red	(-)	Grey	White		—
LDD-F304NI-SI		636	15000	Red	(-)	Grey	White		—
LDD-F306NI		660	9000	Unable to look up Color	(-)	Grey	White		—
LDD-F307NI-USB		470	6000	Blue	(-)	Grey	White		—

UNCONTROLLED DOCUMENT

PART NUMBER		REV.
LDD-F304NI		B

REV.	E.C.N. NUMBER AND REVISION COMMENTS	DATE
A	E.C.N. #10387 & #10407.	5.1.98
B	E.C.N. #10BRDR. & REDRAWN IN 3D.	6.21.03

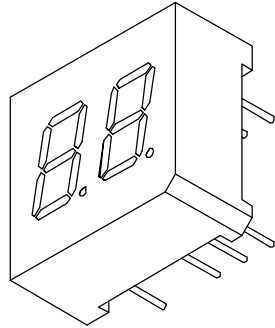
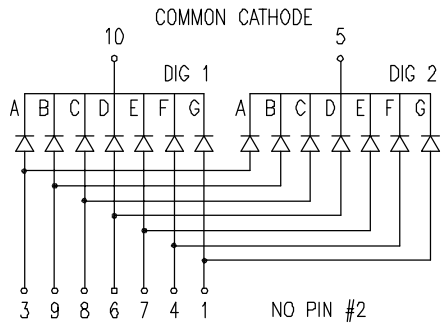
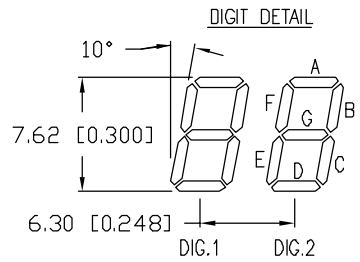
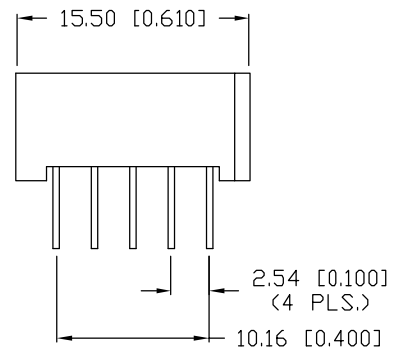
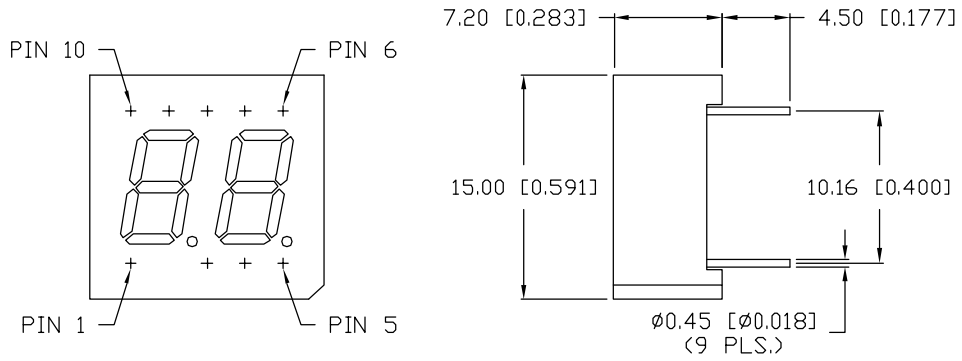

ELECTRO-OPTICAL CHARACTERISTICS $T_A=25^{\circ}\text{C}$ $I_f=10\text{mA}$

PARAMETER	MIN	TYP	MAX	UNITS	TEST COND
PEAK WAVELENGTH		635		nm	
FORWARD VOLTAGE		2.0	2.5	V_f	
REVERSE VOLTAGE	5.0			V_r	$I_r=100\mu\text{A}$
AXIAL INTENSITY		2000		μcd	$I_f=10\text{mA}$
EMITTED COLOR:	RED				
FACE COLOR:	GRAY				
SEGMENT COLOR:	MILKY WHITE DIFFUSED				

LIMITS OF SAFE OPERATION AT 25°C PER CHIPS

PARAMETER	MAX	UNITS
PEAK FORWARD CURRENT*	150	mA
STEADY CURRENT	30	mA
POWER DISSIPATION	105	mW
DERATE FROM 25°C	-1.6	mW/°C
OPERATING, STORAGE TEMP.	-40 TO +85	°C
SOLDERING TEMP.	+260	°C
2.0mm FROM BODY		3 SEC. MAX

* $t < 10\mu\text{S}$

*UNLESS OTHERWISE SPECIFIED TOLERANCES PER DECIMAL PRECISION ARE: X=±1 (±0.039), X.X=±0.5 (±0.020), X.XX=±0.25 (±0.010), X.XXX=±0.127 (±0.005). LEAD SIZE=±0.05 (±0.002), LEAD LENGTH=±0.75 (±0.030). MIN= +DECIMAL PRECISION MAX= +0.00 -DECIMAL PRECISION

UNCONTROLLED DOCUMENT

REV.	PART NUMBER
B	LDD-F304NI

CONFIDENTIAL INFORMATION
 THE INFORMATION CONTAINED IN THIS DOCUMENT IS THE PROPERTY OF LUMEX INC. EXCEPT AS SPECIFICALLY AUTHORIZED IN WRITING BY LUMEX INC., THE HOLDER OF THIS DOCUMENT SHALL KEEP ALL INFORMATION CONTAINED HEREIN CONFIDENTIAL AND SHALL PROTECT SAME IN WHOLE OR IN PART FROM DISCLOSURE AND DISSEMINATION TO ALL THIRD PARTIES.



0.30" SEVEN SEGMENT, DUAL DIGIT, LED DISPLAY,
 635nm RED CHIPS, GRAY FACE WITH WHITE SEGMENTS,
 MULTIPLEXED, COMMON CATHODE.

RELIABILITY NOTE
 OUR MANY YEARS OF EXPERIENCE DATA ACCUMULATION INDICATE THAT SOLDER HEAT IS A MAJOR CAUSE OF EARLY AND FUTURE FAILURE. PLEASE PAY ATTENTION TO YOUR SOLDERING PROCESS.

DRAWN BY:	CHECKED BY:	APPROVED BY:	DATE: 4.17.95
BC			PAGE: 1 OF 1
			SCALE: N/A