



### SNDH-T4L-G01



*Actual product appearance may vary.*

#### Quadrature speed and direction sensor

#### Features

- Hall-effect magnetic sensing technology
- Advanced performance dynamic offset self calibration
- Air gap up to 2 mm [0.08 in]
- Near zero speed
- Automotive under-the-hood packaging integrity
- EMI hardened
- High frequency switching capability (up to 15 kHz)
- -40 °C to 150 °C [-40 °F to 302 °F] continuous operating temperature
- Multiple connector options
- Short circuit protection
- Reverse voltage protection
- Open collector output
- Low jitter output
- O-ring seal

#### Potential Applications

- Steering position
- Tachometers/counter
- Encoders
- Speed and direction of gears and shafts in transmissions, hydraulic motors, pumps and gear boxes

#### Description

The SNDH Series is a dual differential hall sensor that provides speed and direction information using a quadrature output with signals 90 degree phase shifted from each other. Target direction is determined by output lead/lag phase shifting.

This product is designed for applications where extremely high resolution is required at wide frequency ranges, 0 kHz to 15 kHz, and large air gaps. BiCMOS (bipolar complementary metal-oxide-semiconductor) Hall-effect technology, using advanced digital signal processing for dynamic off-set cancellation, provides enhanced air gap performance and phase shift accuracy over most conditions. Unique patented (pending) IC (integrated circuit) packaging provides output phase shift tolerancing with enhanced accuracy.

The robust package is automotive under-the-hood grade for most environmental conditions as well as EMI (electromagnetic interference) hardened. Multiple connection options, including wire harness and integral connector versions using AMP super seal or AMP Jr. Timer connectors, are available. Package design includes an o-ring seal for pressure applications and a fixed mounting flange.

Product Specifications	
Sensing Type	Quadrature speed and direction
Housing Diameter	15 mm [0.6 in]
Barrel Length	45 mm [1.77 in]
Vdc Supply	4.5 Vdc to 18 Vdc
Operating Frequency Range	0 Hz to 15 kHz
Operating Temperature	-40° to 150° C [-40 °F to 302 °F]
Connections	500 mm [19.7 in] leads
Availability	Global
UNSPSC Code	411121
UNSPSC Commodity	411121 Transducers
Series Name	SNDH

---

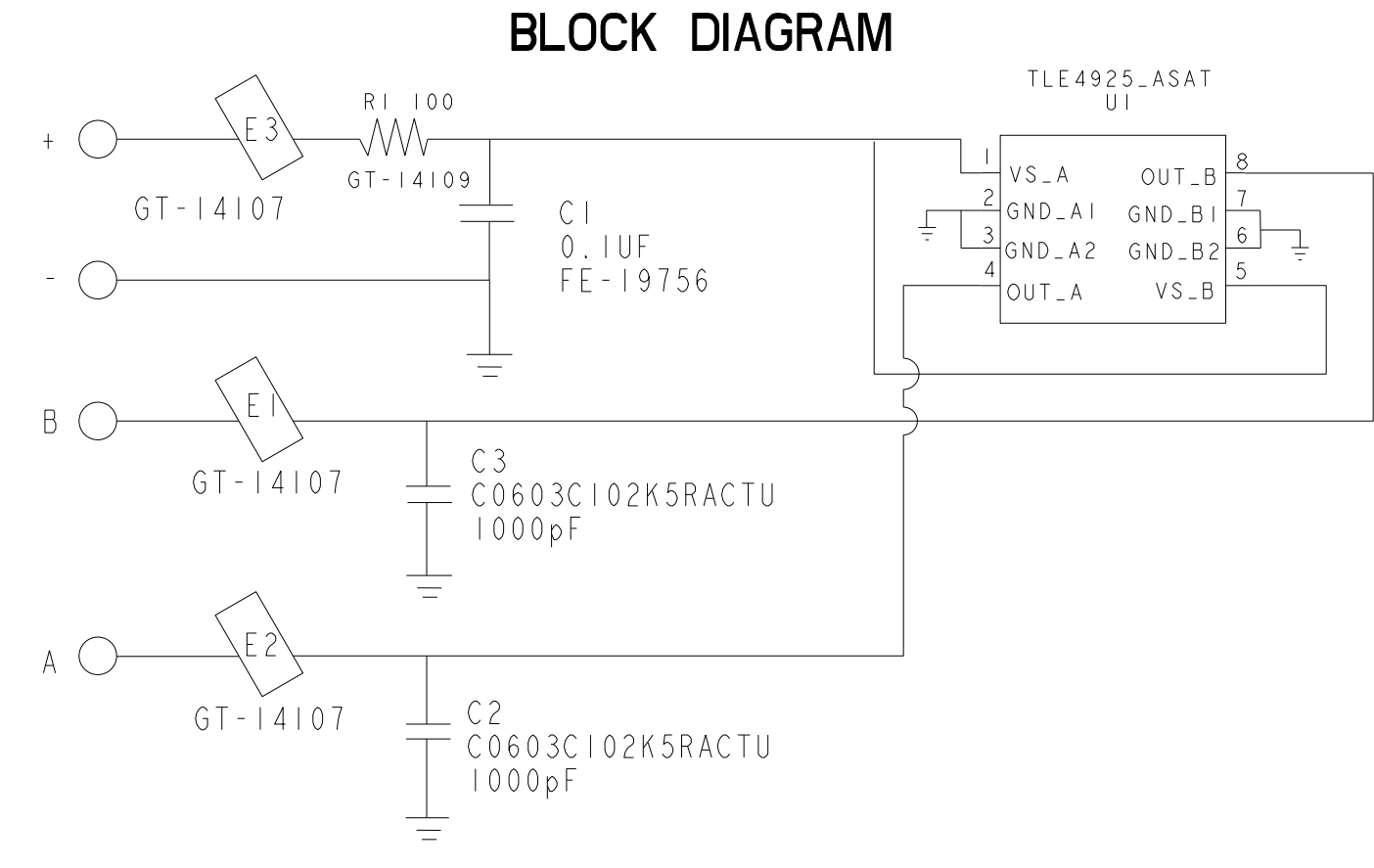
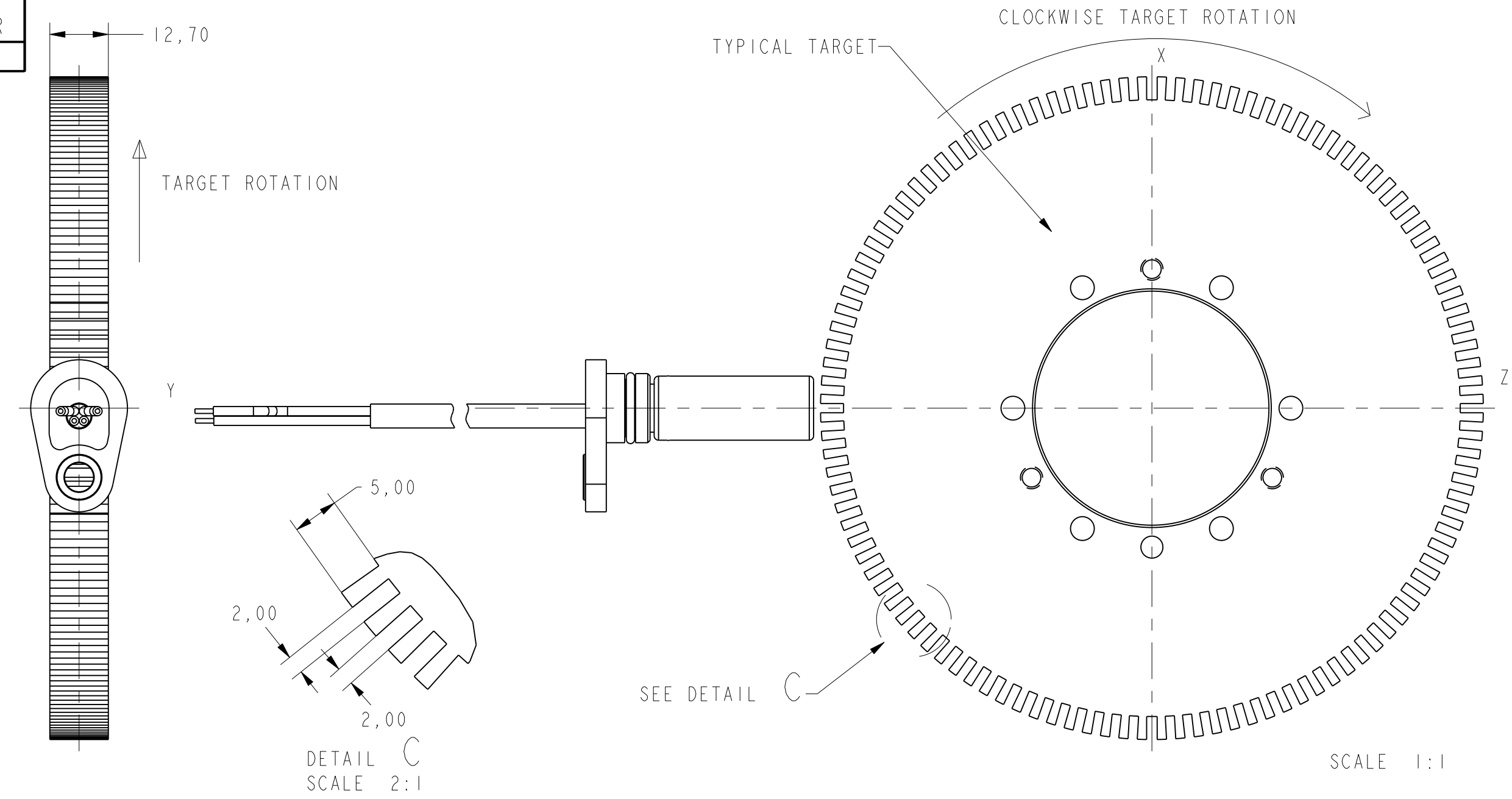

SPECIFICATIONS		
MECHANICAL CONDITIONS		
CONDITION	LIMITS	COMMENTS
SENSING AIR GAP	0.0 - 2.0 MM	MAY ACHIEVE LARGER GAPS WITH TESTING OF ACTUAL TARGET
TARGET TOOTH WIDTH	2.0 MM (RECOMMENDED)	OTHER GEOMETRY MAY BE SUITABLE
TARGET SLOT WIDTH	2.0 MM (RECOMMENDED)	OTHER GEOMETRY MAY BE SUITABLE
TOOTH HEIGHT	> 3.0MM (RECOMMENDED)	SHORTER TOOTH HEIGHTS MAY LIMIT MAX AIR GAP PERFORMANCE
TARGET WIDTH	> 5 MM (RECOMMENDED)	NARROWER TARGETS MAY LIMIT AXIAL OFFSETS
SENSOR MISPOSITION TO TARGET	+/- 1.5 MM	DEPENDENT ON TARGET GEOMETRY

ELECTRICAL CONDITIONS		
CONDITION	LIMITS	COMMENTS
SUPPLY VOLTAGE	4.5 - 18 V	
MAX CONTINUOUS SUPPLY VOLTAGE	18V	
OUTPUT SIGNAL:		
SIGNAL TYPE	SQUARE WAVE	2 CHANNEL, PHASE SHIFTED BY 90 DEG. EITHER CHANNEL CAN LEAD OR LAG
DUTY CYCLE	50 % +/- 10%	
PHASE SHIFT	90° +/- 20°	NOMINAL MAY BE VARIED IF REQUIRED
OUTPUT HIGH	>= VS - 0.5 VOLTS	
OUTPUT LOW	<= 0.5 VOLTS	
LOAD CURRENT	20 MA MAX	EACH OUTPUT AT ALL CONDITIONS
RISE TIME	10 US (TYPICAL)	DEPENDENT ON LOAD RESISTOR
FALL TIME	1US (TYPICAL)	
FREQUENCY	0 TO 15 KHZ	HIGHER FREQUENCIES ABOVE 10KHZ MAY BE DEPENDANT ON TARGET GEOMETRY AND AIR GAP.
SHORT CIRCUIT PROTECTION	80MA	
SUPPLY:		
CURRENT (NORMAL)	13.6MA	ALL CONDITIONS
CURRENT (MAX)	18 MA	ALL CONDITIONS
REVERSE VOLTAGE	-18V MAX	CONTINUOUS

ENVIRONMENTAL CONDITIONS		
CONDITION	TEST PARAMETER	COMMENTS
EMI:		
RADIATED IMMUNITY	100 V/M PEAK	400-2GHZ
BULK CURRENT INJECTION	60 MA	20-400MHZ
ESD	16/8 KV AIR/CONTACT	AGAINST THE CONNECTOR (150PF, 330 OHMS)
FAST TRANSIENT BURST	EN-61000-4-4 LEVEL 4	
EMISSION	EN-61000-6-4	
AUTOMOTIVE TRANSIENTS	ISO 7636/3, TEST PULSE A&B @ ±80V	
OPERATING TEMPERATURE	-40° TO 150 °C	CONTINUOUS
THERMOSHOCK	-40° TO 150 °C	AIR TO AIR, 1/2 HOUR DWELL, < 10S TRANSITION
HUMIDITY	168 HRS	95% HUMIDITY AT 90 C
SALT FOG	96 HOURS	DIN IEC 6872-11
THERMO SALINE DUNK	5 DUNKS	105C TO 0C AIR TO LIQUID, 5% SALINE
HIGH TEMP EXPOSURE W/POWER	1000 HRS @ 150 °C	
MECHANICAL SHOCK	50G	
VIBRATION	30G, 10 - 2KHZ	
RESISTANCE TO FLUIDS	GENERAL AUTOMOTIVE UNDER THE HOOD FLUIDS	

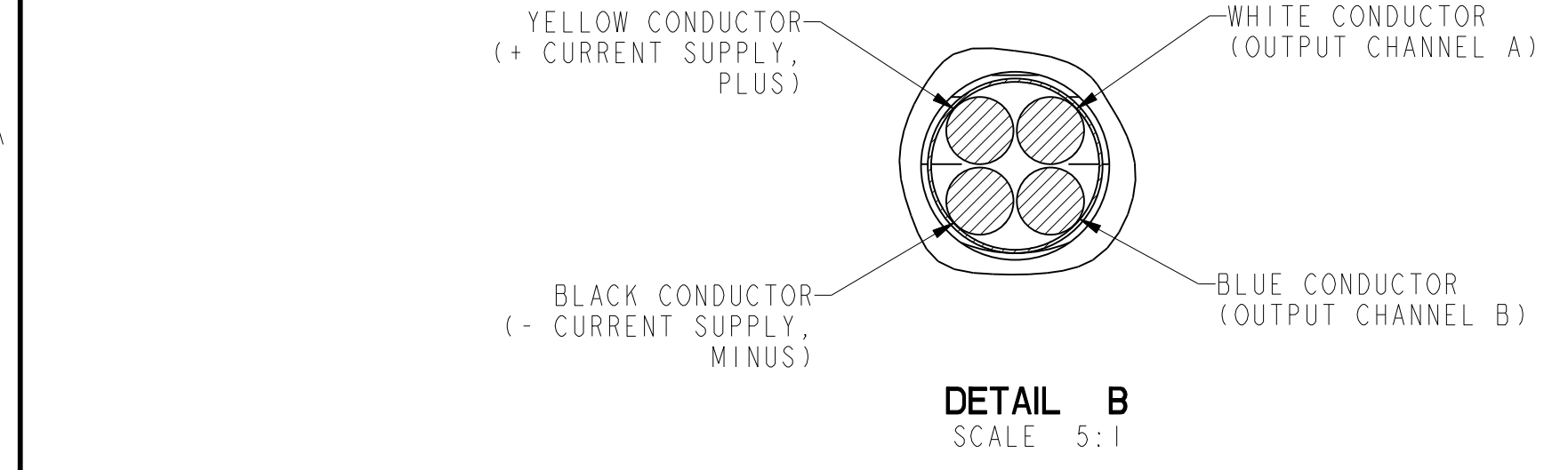
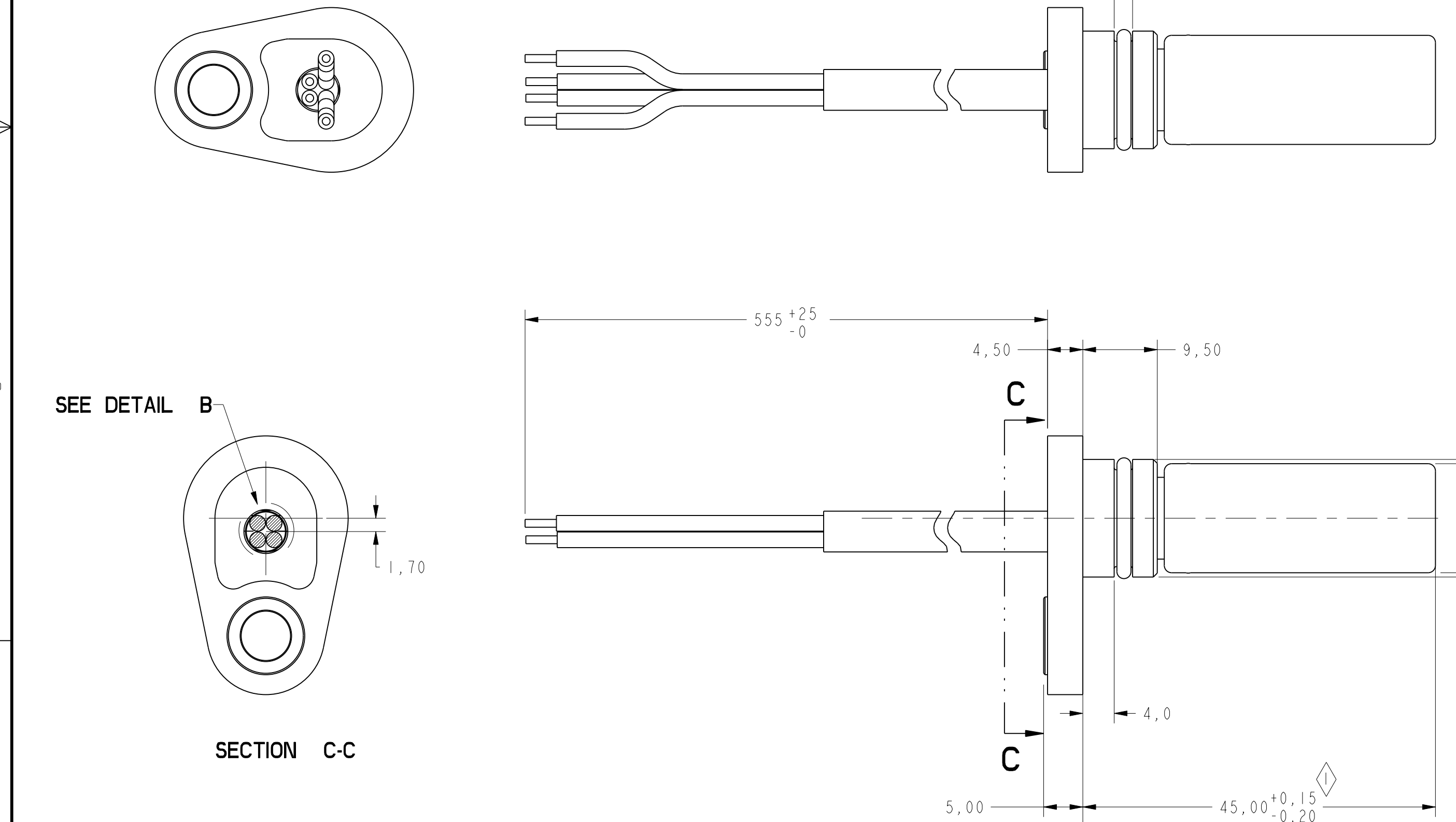
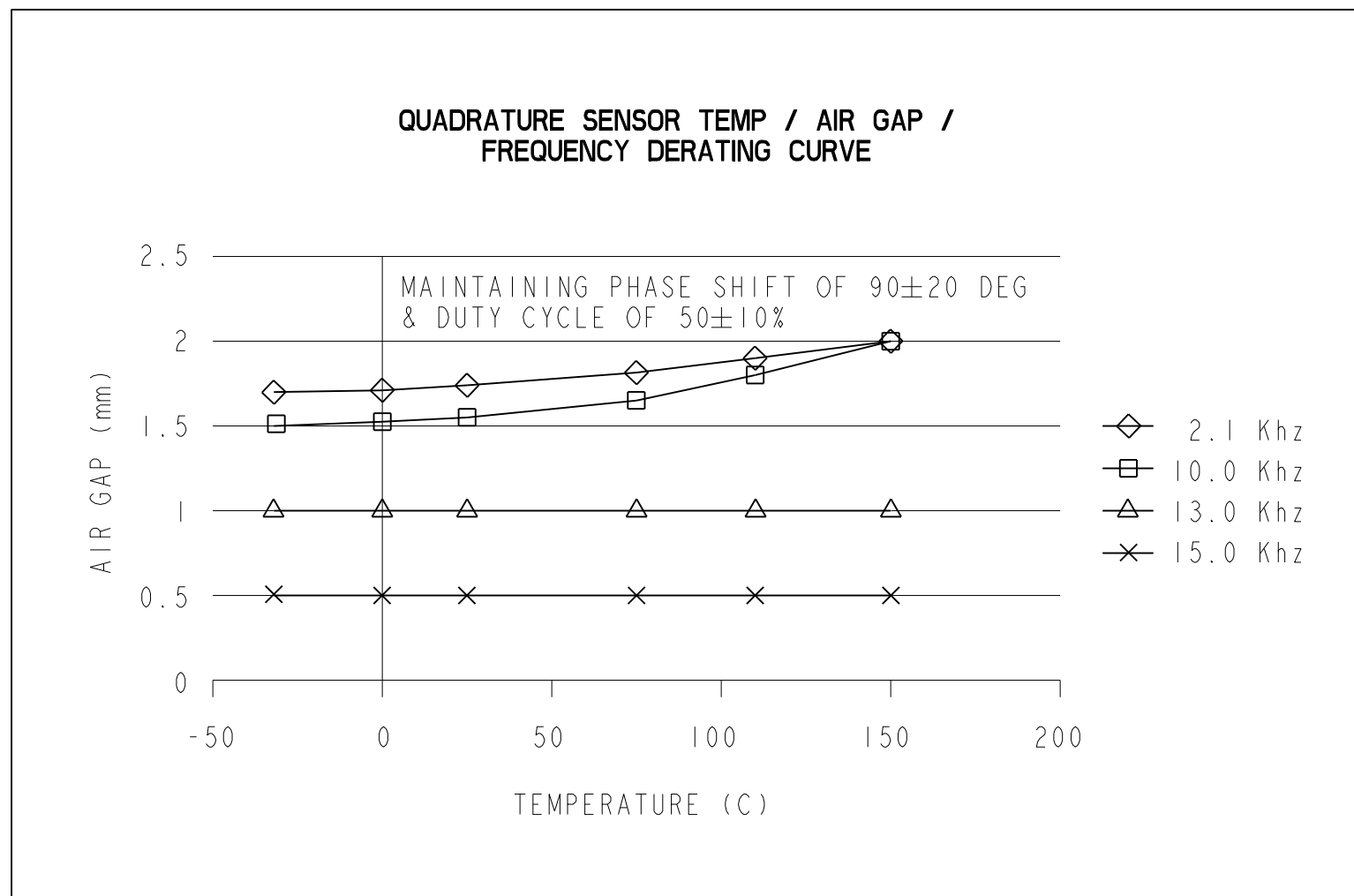

NOTES  
1 - MATERIALS:  
INSERT = PLASTIC VALOX K4560  
BUSHING = MACHINED BRASS  
O-RING = FLUOROCARBON (VITON)  
HOUSING = 304 STAINLESS STEEL  
WIRE HARNESS=LEONI FLR4G11Y 4x0.5/1192.5.2  
TARGET = C1018 STEEL, ELECTROLESS NICKEL PLATING  
2 - RECOMMENDED MOUNTING BORE 15.05+0.10/-0.00

KEY PRODUCT CHARACTERISTICS			
⊕	SAFETY/COMPLIANCE	◇	FIT/FUNCTION
⊗	S/C CHECKPOINTS	⊠	F/F CHECKPOINTS
NO. & TYPE	DESCRIPTION	RATIONALE	PTS.
◇	SENSOR FACE TO MOUNTING FLANGE DISTANCE	MAJOR CONTRIBUTOR TO AIR GAP DISTANCE	

DESIGN UNITS: MM	DRAWN	DDN	14 DEC 06
TOLERANCES UNLESS NOTED:	CHECK	PREM	14 DEC 06
NO PLACES	x	±	1,000
ONE PLACE	.x	±	0.4
TWO PLACE	.xx	±	0.15
THREE PLACE	.xxx	±	0.005
FOUR PLACE	.xxxx	±	0.0050
ANGLES	x	±	3

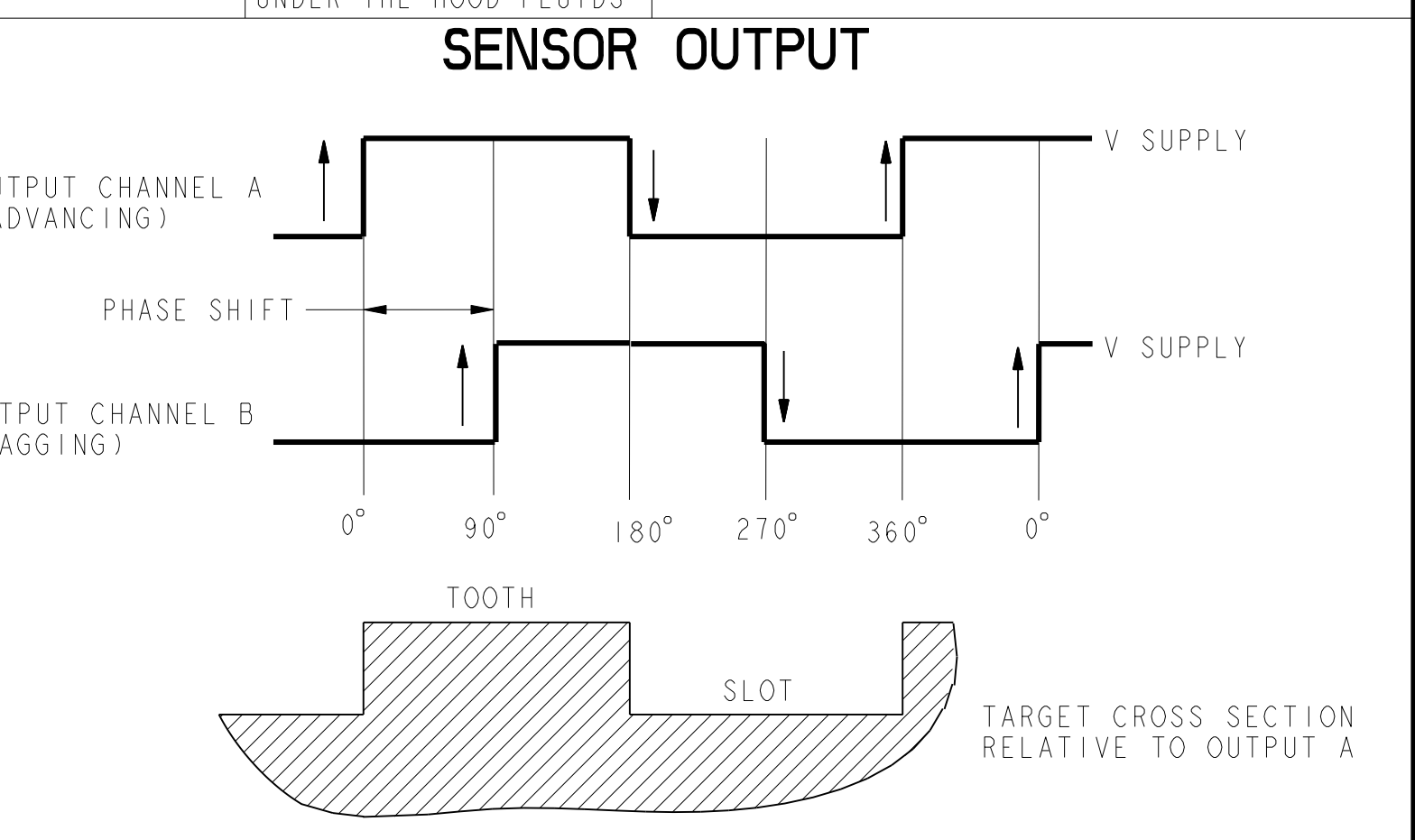

<b>Honeywell</b>		TITLE	
		<b>SENSOR, SPEED &amp; DIRECTION</b>	
SIZE	TYPE	DRAWING NAME	REV
D	I	SNDH-T4L-G01	C
THIRD ANGLE PROJECTION		Pro/ENGINEER	3D SCALE 2:1
		SHEET	1 OF 1

## SNDH Series

### Quadrature General Industrial Speed and Direction Sensors



#### DESCRIPTION

The SNDH Series is a dual differential hall sensor that provides speed and direction information using a quadrature output with signals 90° phase shifted from each other. Target direction is determined by output lead/lag phase shifting.

This product is designed for applications where extremely high resolution is required at wide frequency ranges, 0 kHz to 15 kHz, and large air gaps. BiCMOS (bipolar complementary metal-oxide-semiconductor) Hall-effect technology, using advanced digital signal processing for dynamic off-set cancellation, provides enhanced air gap performance and phase shift accuracy over most conditions.

#### FEATURES

- Hall-effect magnetic sensing technology
- Dual differential Hall provides enhanced target resolution
- Advanced performance dynamic offset self calibration
- Air gap up to 2 mm [0.08 in]
- Near zero speed
- Automotive under-the-hood packaging integrity
- EMI hardened
- High frequency switching capability (up to 15 kHz)
- -40 °C to 150 °C [-40 °F to 302 °F] continuous operating temperature
- Multiple connector options
- Short circuit protection
- Reverse voltage protection
- Open collector output
- Low jitter output
- O-ring seal

Unique patented (pending) IC (integrated circuit) packaging provides output phase shift tolerancing with enhanced accuracy.

The robust package is automotive under-the-hood grade for most environmental conditions as well as EMI (electromagnetic interference) hardened. Multiple connection options, including wire harness and integral connector versions using AMP super seal or AMP Jr. Timer connectors, are available. Package design includes an o-ring seal for pressure applications and a fixed mounting flange.

#### POTENTIAL APPLICATIONS

- Steering position
- Tachometers/counters
- Encoders
- Speed and direction of gears and shafts in transmissions, hydraulic motors, pumps, and gear boxes

# SNDH Series

**TABLE 1. SPECIFICATIONS**

Characteristic	Parameter	Note
Sensing air gap	0 mm to 2,0 mm [0 in to 0.08 in]	may achieve larger gaps with testing of actual target
Target tooth width	2,0 mm [0.08 in] (recommended)	other geometry may be suitable
Target slot width	2,0 mm [0.08 in] (recommended)	other geometry may be suitable
Tooth height	>3,0 mm [0.12] (recommended)	shorter tooth heights may limit max. air gap performance
Target width	>5,0 mm [0.20] (recommended)	narrow targets may limit axial offsets
Sensor misposition to target	±1,5 mm [0.06]	dependent on target geometry
EMI radiated immunity	100 V/m peak	400 Hz to 2 GHz
EMI bulk current injection	60 mA	20 MHz to 400 MHz
EMI ESD	16/8 KV air/contact	against the connector (150 pF, 330 Ohm)
EMI fast transient burst	EN61000-4-4 Level 4	—
Operating temperature	-40 °C to 150 °C [-40 °F to 302 °F]	continuous
Thermoshock	-40 °C to 150 °C [-40 °F to 302 °F]	—
Humidity	168 hr	95% humidity at 90 °C [194 °F]
Salt fog	96 hr	DIN IEC 6872-11
Thermosaline dunk	5 dunks	105 °C to 0 °C [221 °F to 32 °F] air to liquid, 5% saline
High temp exposure with power	1000 hs at 150 °C [302 °F]	—
Mechanical shock	50 g	—
Vibration	30 g, 10 Hz to 2 kHz	—
Resistance to fluids	general automotive under the hood fluids	—
Supply voltage	4.5 V to 18 V	—
Max. continuous supply voltage	18 V	—
Reverse voltage	-18 V max.	continuous
Current (normal)	13.6 mA	all conditions
Current (max.)	18 mA	all conditions
Short circuit protection	80 mA	—
Output signal type	square wave	two channel, phase shifted by 90°, either channel can lead or lag, push/pull
Duty cycle	50% ±10%	—
Phase shift	90% ±20%	using recommended target tooth/slot
Output high	≥Vs - 0.5 V	—
Output low	≤0.5 V	—
Load current	20 mA max.	each output at all conditions
Output low	≤0.5 V	—
Rise time	10 μs typ.	dependent on load resistor
Fall time	1 μs typ.	—
Frequency	0 Hz to 15 kHz	higher frequencies about 10 kHz may be dependent on target geometry and air gap

**FIGURE 1. WIRING DIAGRAM**

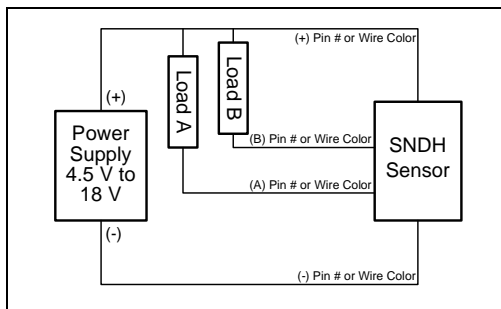

**FIGURE 2. SENSOR OUTPUT**

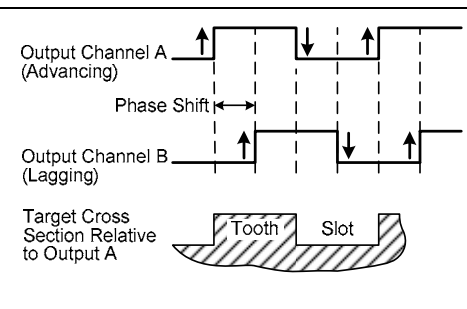

**FIG. 3. TEMPERATURE/AIR GAP/FREQUENCY DERATING CURVE**

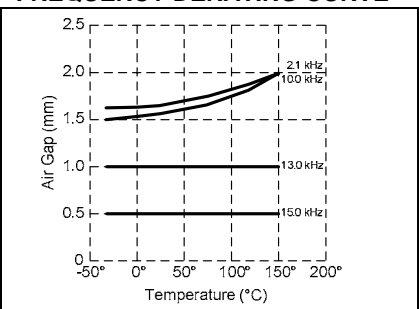

# Quadrature Speed and Direction Sensors

**MOUNTING DIMENSIONS (For reference only: mm [in])**

**FIGURE 4. SNDH-T4C-G01**

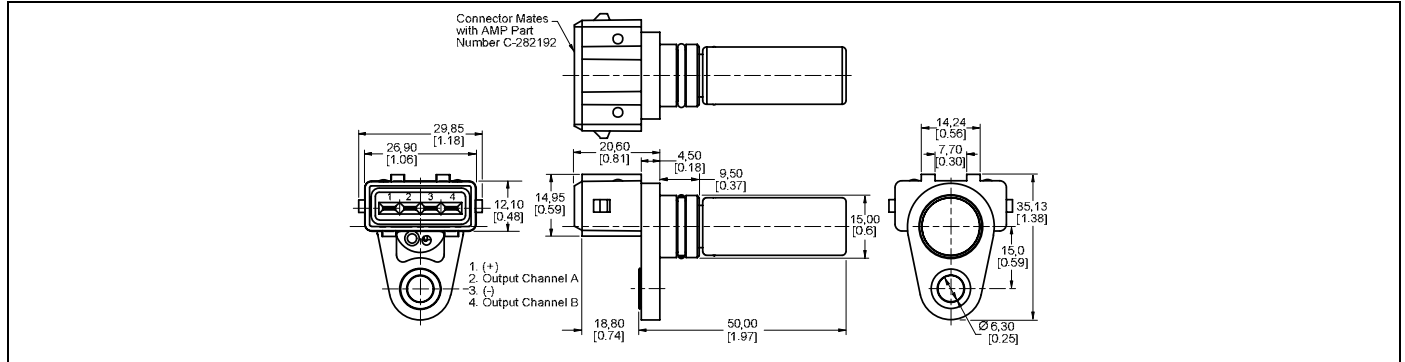

**FIGURE 5. SNDH-T4L-G01**

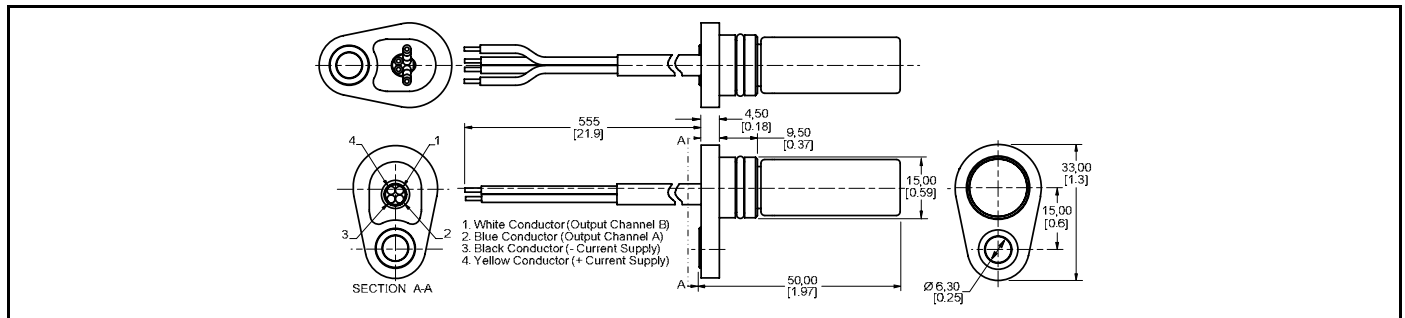

**FIGURE 6. SNDH-T4P-G01**

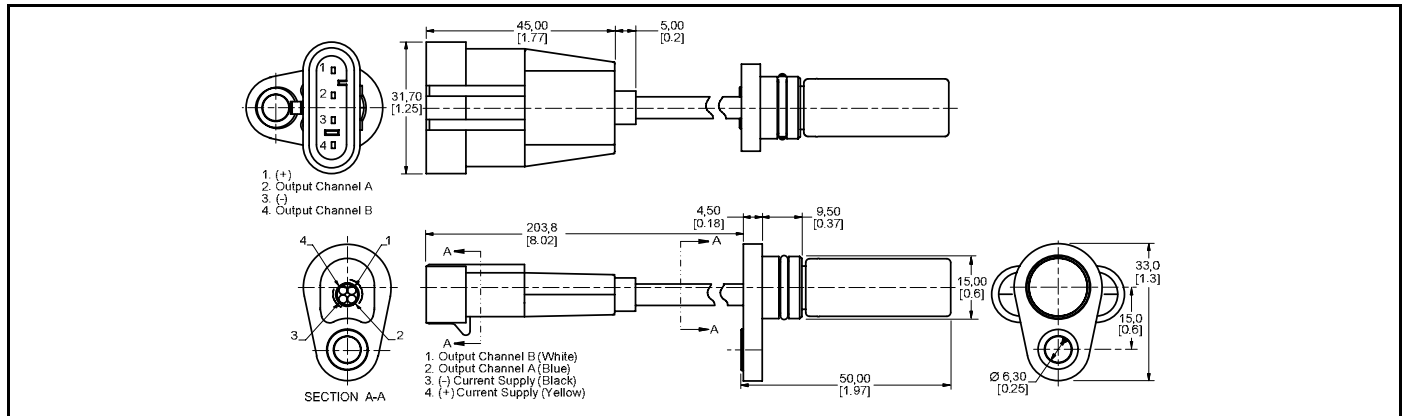

**FIGURE 7. SNDH-T4P-G02**

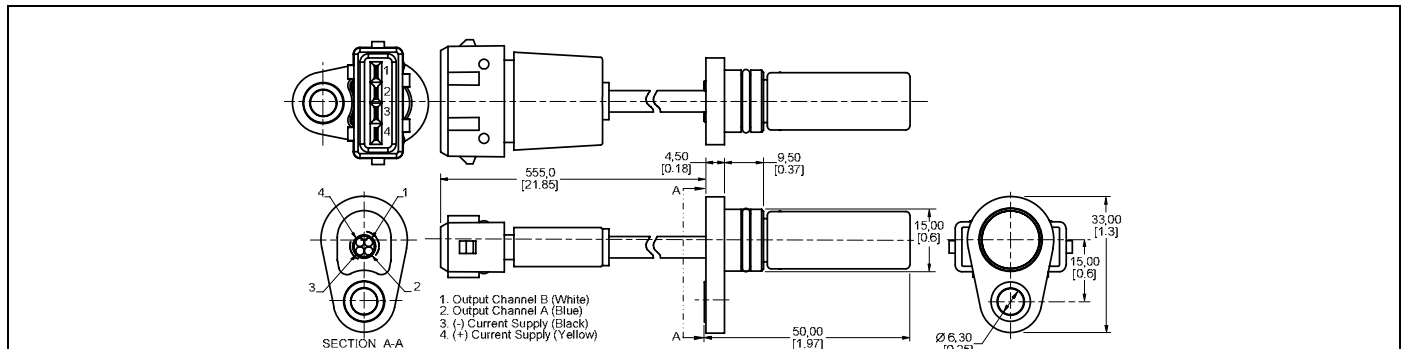

**FIGURE 8. GENERAL MOUNTING GEOMETRY**

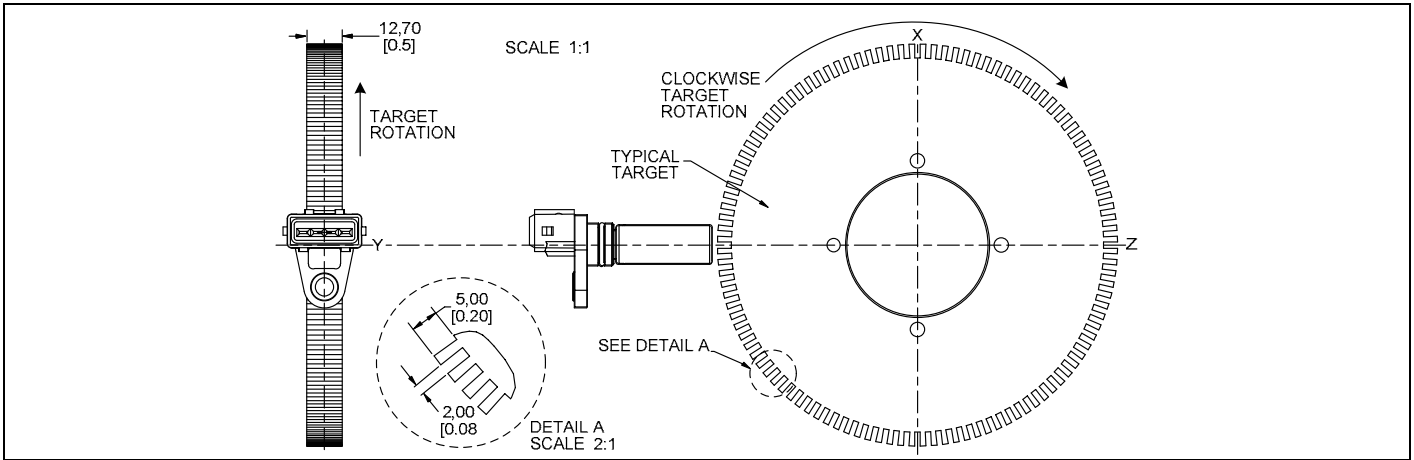

**ORDER GUIDE**

Catalog Listing	Description
SNDH-T4C-G01	SNDH Series, dual hall speed and position sensor, 4 wire output, connector
SNDH-T4L-G01	SNDH Series, dual hall speed and position sensor, 4 wire output, leadwire
SNDH-T4P-G01	SNDH Series, dual hall speed and position sensor, 4 wire output, pigtail with rectangular connector
SNDH-T4P-G02	SNDH Series, dual hall speed and position sensor, 4 wire output, pigtail with oval connector