

GG-12A AIRCRAFT WARNING LAMP

DOUBLE CONTACT INDEX BAYONET BASE

28V 14W/40W

WAMCO PART NO.	ENVELOPE SIZE	BASE TYPE	RATING	FILAMENT SHAPE
WL-A-7796A-24	GG-12A	BAY15d	28V 14W/40W	C-6V/CC-6

TEST VOLTS	CURRENT (A)			LIGHT OUTPUT (MSCP)			LIFE HRS
	MIN	NOM	MAX	MIN	NOM	MAX	
28V	.460	.500	.540	SEE NOTE 4			300
	1.32	1.43	1.54				150

DIMENSIONAL CHARACTERISTICS

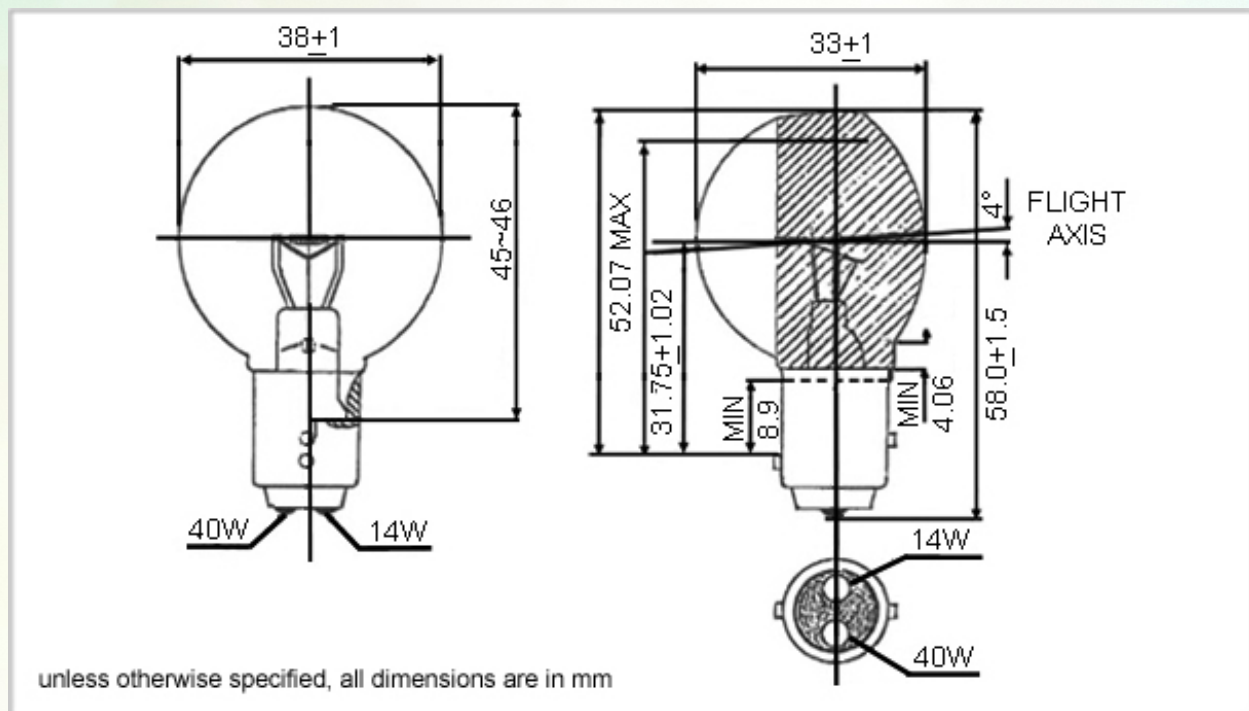

NOTES

1. Finish clear, except where reflective surface is required
2. Reflective coating must conform to the coating adhesion requirements of MIL-L-6363F, paragraph 4.6.6
3. Dual filament lamp
4. Center of beam to fall within 3° vertically and 5° horizontally of a line through the filament in the plane of base pins, making an angle of 86° with the base axis
5. Park mark WL-A-7796A-24, 28V, 14W/40W
6. RoHS compliant

