

GG-12B AIRCRAFT WARNING LAMP

SINGLE CONTACT INDEX BAYONET BASE

6.2V 40W

WAMCO PART NO.		ENVELOPE SIZE		BASE TYPE	RATING	FILAMENT SHAPE
WL-626		GG-12B		BAY15s	6.2V 40W	C-6
TEST VOLTS	CURRENT (A)			LIGHT DISTRIBUTION		LIFE HRS
	MIN	NOM	MAX	300 CANDLE POWER MINIMUM ON REFLECTOR AXIS HORIZONTAL AND VERTICAL BEAM SPREAD TO 150 CANDLE POWER, 40° MINIMUM		
6.2V	6.00	6.45	6.90			300

DIMENSIONAL CHARACTERISTICS

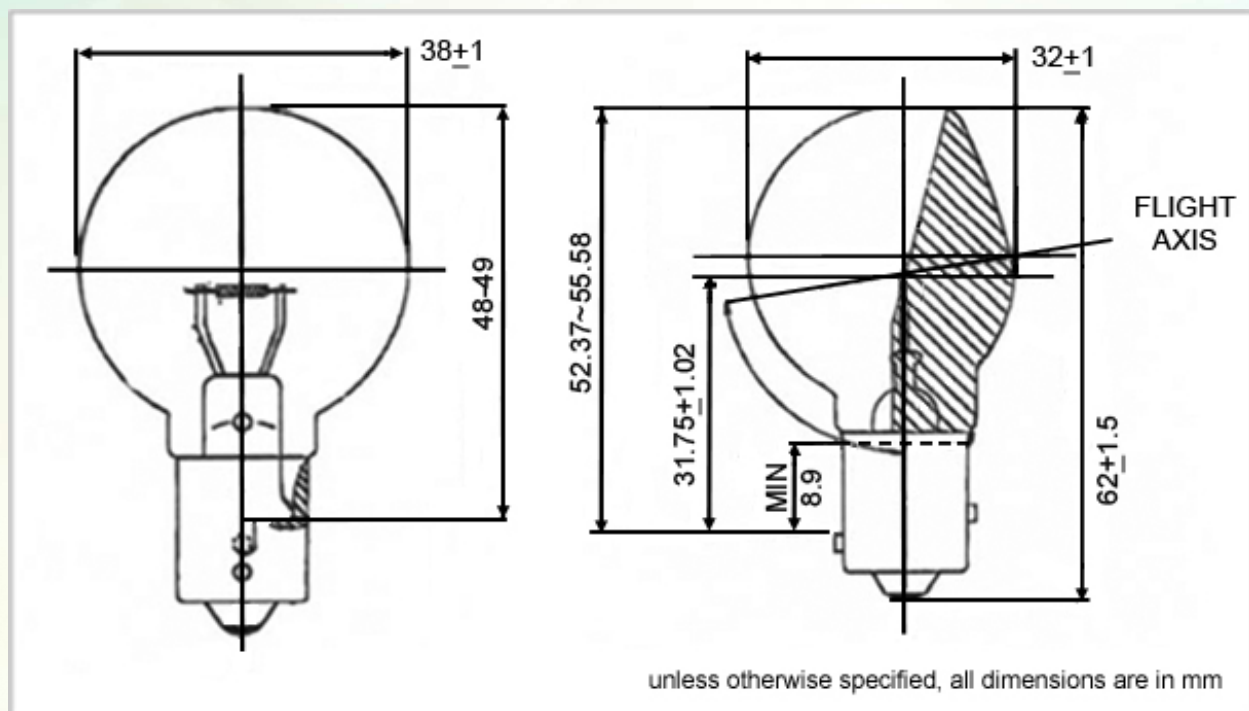

NOTES

1. Finish clear, except where reflective surface is required
2. Reflective coating must conform to the coating adhesion requirements of MIL-L-6363F, paragraph 4.6.6
3. Nickel center contact
4. Part mark WL-626, 6.2V, 40W
5. RoHS compliant
6. ANSI trade number 626

