

Wamco Part No.	Envelope Size	Base Type	Rating	Filament Shape
WL-44	T-3¼	BA9s	6.3V .250A	C-2R

Test Volts	Current (A)			Light Output (MSCP)			Life Hours
	Min.	Nom.	Max.	Min.	Nom.	Max	
6.3	.225	.250	.275	.675	.900	1.125	3,000 Hrs

Dimensional Characteristics:

1. L.C.L = .78" (19.8mm)
2. Base = Nickel-plated Brass Construction
3. ANSI Standard. No. 44
4. Part Mark: WL-44

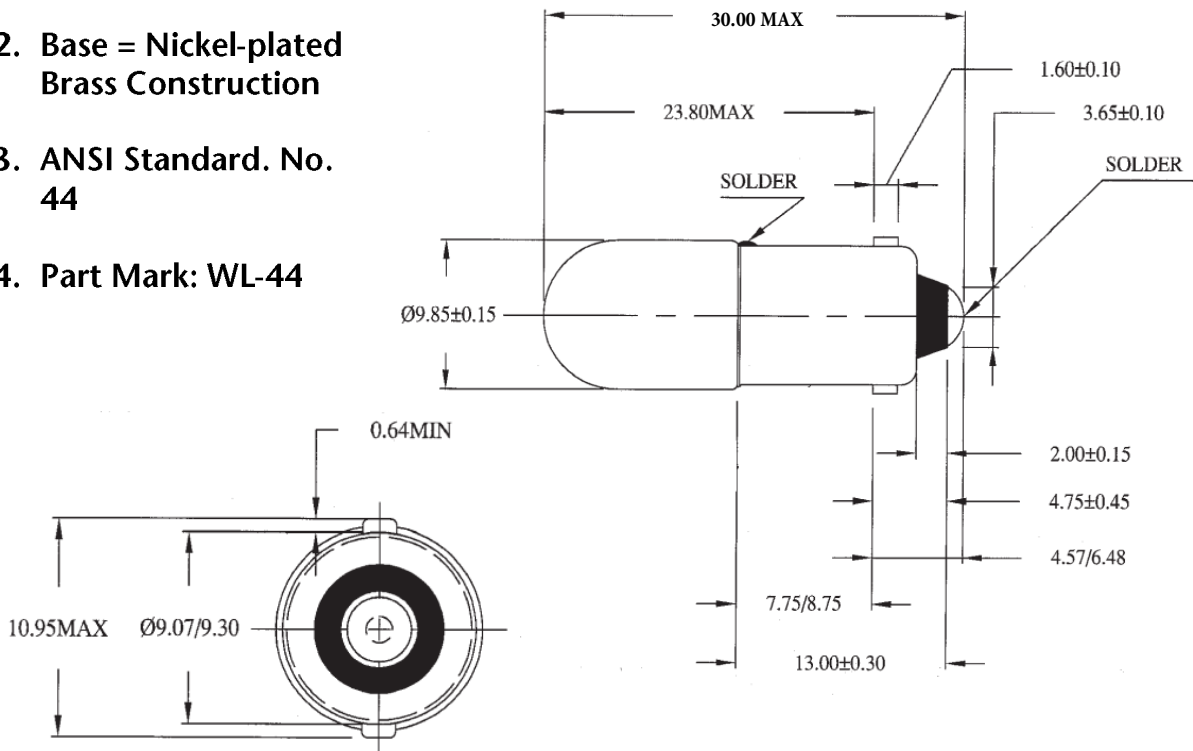

RoHS Compliant

			Title:	
			T-3¼ Miniature Bayonet Base Lamp 6.3V .250A Vacuum	
Revised	01/24/12	EB		
Drawn	06/08/09	SL	Notes: Unless otherwise specified, all dimensions are in mm.	Rev: 3
Checked	06/08/09	EB		
Approved	06/08/09	EB		