



[Part Information](#) | [Outline Drawing](#) | [Download PDF File](#)

Part Information:



Part Number: 125-3017-068

Description: Ultra 320 Compliant Flat, 30 AWG stranded, TPO, 5.25

Family: Internal SCSI

Outline Drawing

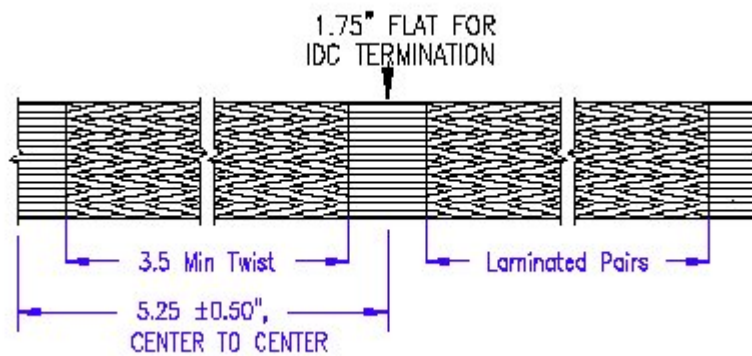

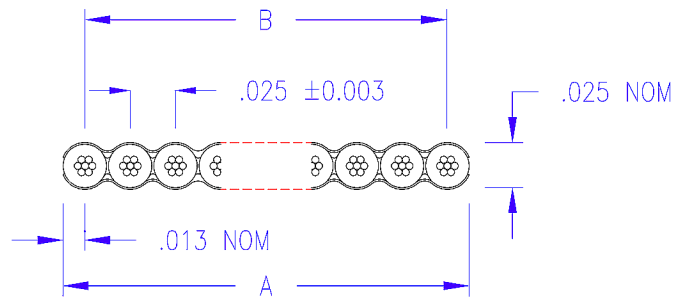
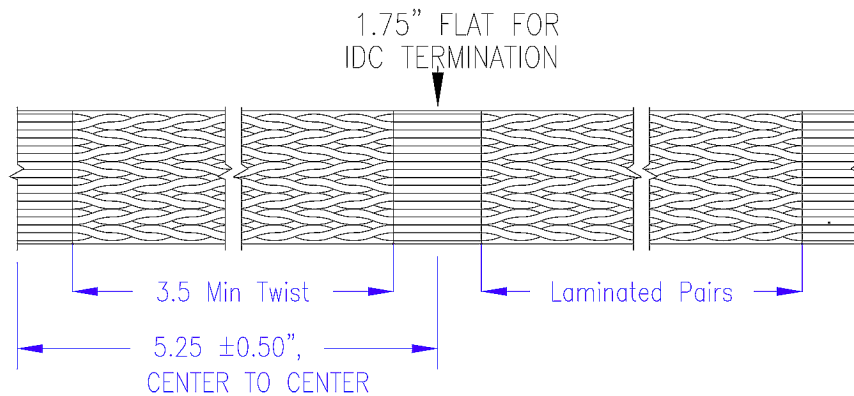

CROSS SECTION THRU FLAT

Part Number	Count	Pairs	A Span	B Span
125-3017-068	68	34	1.701 ±0.012	1.675 ±0.010
125-3017-080	80	40	2.001 ±0.012	1.975 ±0.010

Alternative Twist Lengths Available, Consult Factory for Ordering Information.

All Dimensions in Inches, Unless Otherwise Noted

PHYSICAL

Conductors: 30 AWG 7/38 Tinned Copper
 Insulation: .006" TPO
 Color Code: 1st Pair Red/White followed by Orange/White and Repeat
 Laminate: Polyester
 Temperature Rating: 80°C

ELECTRICAL

Impedance: 90 ±6 ohms¹ 122 ±5 ohms²
 Capacitance: 17 pF/ft @ 1 MHz¹ 11 pF/ft @ 1 MHz²
 Propagation Delay: 1.45 ns/ft
 Voltage Rating: 150 V
 Current Rating: 0.75 A
 DC Resistance: 106 ohm per 1,000 ft @ 20°C

¹ Above values measured Single-Ended, with one conductor of each pair commoned to one Buss(SCSI Mode)

² Above values measured Differentially.

Approvals: UL AWM Style 20744
 CSA AWM

Print Legend: **Amphenol SPECTRA-STRIP**

UL[®] AWM 80C LL31941 CSA AWM I A80C 150V FT-1
 30 AWG Stranded Ultra 320 SCSI™ Compliant <Date Code>
 Spectra-Green Lead Free/PBB Free

DRAWN	PROD ENG	QA	MKT	P/ECN#	DRAWING NO. 125-3017-068 & -080	AMPHENOL SPECTRA-STRIP	Rev E
					TITLE: .025" Twist 'N' Flat		SHEET
					Full Lamination, 30 AWG 7/38		1 of 1