

REV.	EC #	REVISION DESCRIPTION	DATE	D.ENG.	CHECKER
001	2887	RELEASE TO PRODUCTION	06/08/00	BARB	MZ
002	6579	CHANGE 22AWG TO 18AWG. ADD PROD.ID LABEL	09/22/04	DTM	DW

ebn-papst MFG. NOTES
 1 LEAD DIMENSION IS AT FULL EXTENSION

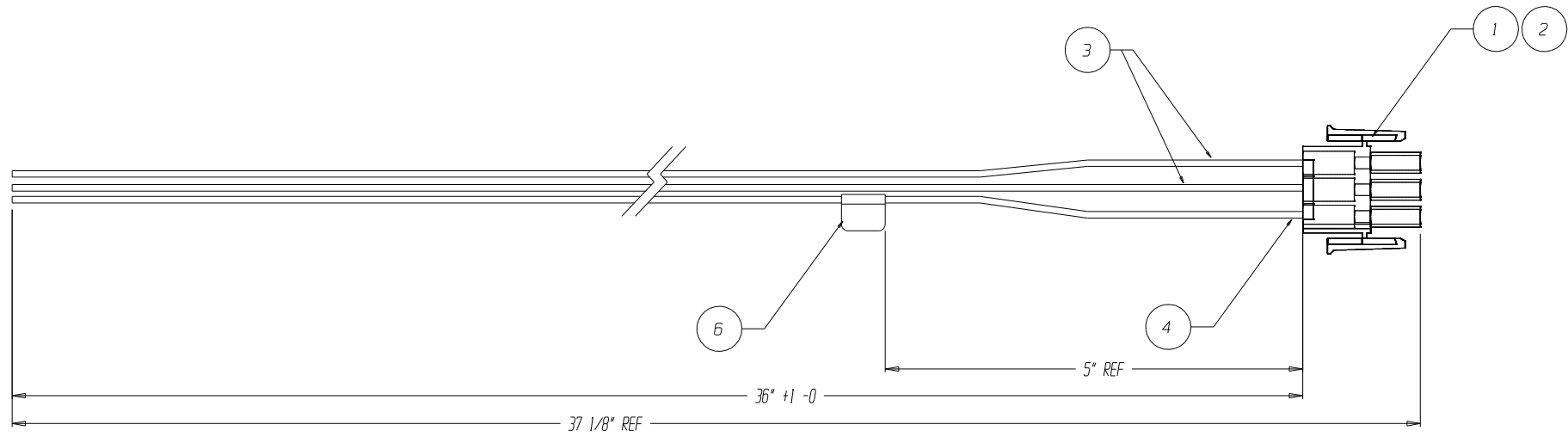

LEAD PIN CALLOUT	
PIN 1	BLACK
PIN 2	BLACK
PIN 3	GREEN/YELLOW

ITEM	QTY	PART NUMBER	DESCRIPTION
6	1	605-50-2660	PRODUCT ID LABEL
5	1	400-50-0003	WIRE TIE 4"
4	1	410-18-0003	GREEN/YELLOW AWG18 UL1007
3	2	410-18-0014	BLACK AWG18 UL1007
2	3	405-12-0089	AMP 350536-1 TERM (REEL)
	REF	405-12-0006	AMP 350550-1 TERM (LOOSE)
1	1	405-14-0004	AMP 350766-1 CONNECTOR

ebn-papst Inc. DISCLOSURE THIS DOCUMENT IS THE PROPERTY OF ebn-papst Inc. ITS USE IS AUTHORIZED BY ebn-papst Inc. ONLY. ALL QUESTIONS MUST BE REFERRED TO ebn-papst Inc. PERSONNEL: DESIGN ENG., MFG.ENG., AND / OR PURCHASING. CAUTION: ANY PRINTED COPY IS UNCONTROLLED AND TO BE USED FOR REFERENCE ONLY. REFER TO ebn-papst In. CAD SYS. FOR VERIFICATION. Form No. 1073 Rev. H	MATERIAL: N/A	BEND DEDUCTION N/A	PART NO. 420-05-0276	
	FINISH: N/A	COSMETICS PER ebn-papst SPEC-Q-1	TITLE AC POWER CONTROL HARNESS	
	IF APPLICABLE PLACE SECOND FINISH AND DESCRIPTION HERE	SEE CAD FOR DIMS. NOT SHOWN	FIRST USED ON 420-05-0276	
ALL INNER BEND RADI = 1mm BOTTOM BEND UNLESS OTHERWISE STATED	BREAK ALL SHARP EDGES	DESIGN ENG. DTM	ORIG. DATE 05/01/00	REVISTION 002
TOLERANCES, UNLESS OTHERWISE STATED:	ALL DIMENSIONS ARE IN INCHES	DECIMAL .XXX ± .020	Holes .XXX ± .003	E# EA-0663
DECIMAL .XX ± .030	Holes .XX ± .003	TOLERANCES FOR CNC FLAT .XXX EXCLUDING HOLE DIA. +/- .010	ANGLES ± 1° REF	SHEET 1 OF 1

WIRE TIE USED TO BUNDLE WRAP