

SKN 141F



Stud Diode

Fast Recovery Rectifier Diode

SKN 141F

SKR 141F

Features

- Small recovered charge
- Soft recovery
- Hermetic metal case with glass insulator
- Threaded stud M12
- SKN: anode to stud;
SKR: cathode to stud

Typical Applications

- Inverse diode for GTO and asymmetric thyristor
- Inverters and choppers
- A.C. motor control
- Uninterruptible power supplies (UPS)

V_{RSM} V	V_{RRM} V	$I_{FRMS} = 260$ A (maximum value for continuous operation) $I_{FAV} = 140$ A (sin. 180; 1000 Hz; $T_c = 100$ °C)	
1200	1200	SKN 141F12	SKR 141F12
1400	1400	SKN 141F14	SKR 141F14
1500	1500	SKN 141F15	SKR 141F15
1700	1700	SKN 141F17	SKR 141F17

Symbol	Conditions	Values	Units
I_{FAV}	sin. 180; $T_c = 85$ (100) °C	168 (140)	A
I_{FAV}	K1,1F; $T_a = 35$ °C; sin. 180; 1000 Hz	114	A
I_{FSM}	$T_{vj} = 25$ °C; 10 ms	2500	A
	$T_{vj} = 150$ °C; 10 ms	2100	A
i^2t	$T_{vj} = 25$ °C; 8,3 ... 10 ms	31000	A ² s
	$T_{vj} = 150$ °C; 8,3 ... 10 ms	22000	A ² s
V_F	$T_{vj} = 25$ °C; $I_F = 300$ A	max. 1,8	V
$V_{(TO)}$	$T_{vj} = 150$ °C	max. 1,1	V
r_T	$T_{vj} = 150$ °C	max. 2	mΩ
I_{RD}	$T_{vj} = 25$ °C; $V_{RD} = V_{RRM}$	max. 1	mA
I_{RD}	$T_{vj} = 150$ °C; $V_{RD} = V_{RRM}$	max. 100	mA
Q_{rr}	$T_{vj} = 150$ °C; $I_F = 100$ A,	90	μC
I_{RM}	$-di/dt = 100$ A/μs, $V_R = 400$ V	90	A
t_{rr}		2000	ns
E_{rr}		-	mJ
$R_{th(j-c)}$		0,2	K/W
$R_{th(c-s)}$		0,08	K/W
T_{vj}		- 40 ... + 150	°C
T_{stg}		- 55 ... + 150	°C
V_{isol}		-	V~
M_s	to heatsink	10	Nm
a		5 * 9,81	m/s ²
m	approx.	100	g
Case		E 31	

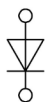

SKN

SKR

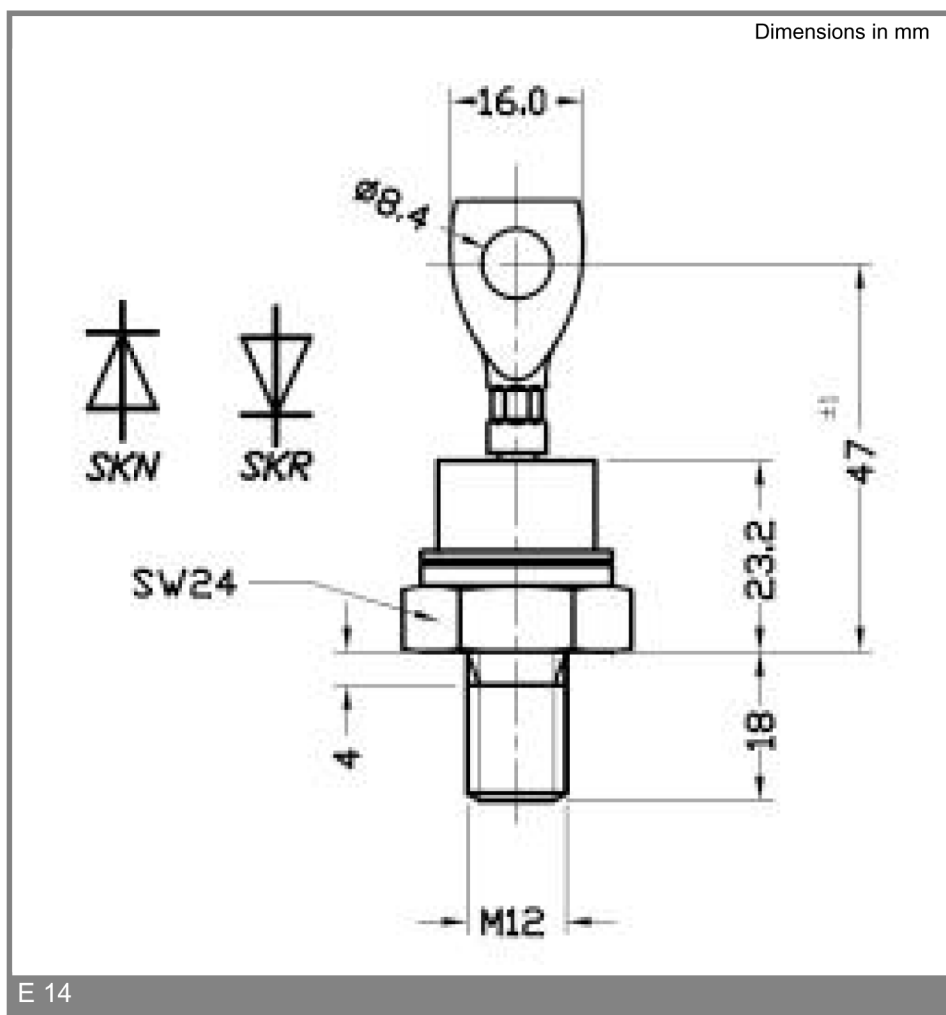

This technical information specifies semiconductor devices but promises no characteristics. No warranty or guarantee expressed or implied is made regarding delivery, performance or suitability.