

PRODUCT TOOL PT-18

Rotron Muffler foam change

In an effort to improve our products, we are eliminating the acoustical fiberglass muffler material. This has been replaced with acoustical foam. In each muffler tower there are pieces of white foam. This foam is to be placed nearest the impeller in the outlet side of the muffler tower. The white foam piece is a high temperature version which needs to be placed as shown below.

BASE MOUNT

PLACE WHITE FOAM INSERT (#18) NEXT TO HOUSING, IN "OUT" PORT OF MUFFLER TOWER AS SHOWN.

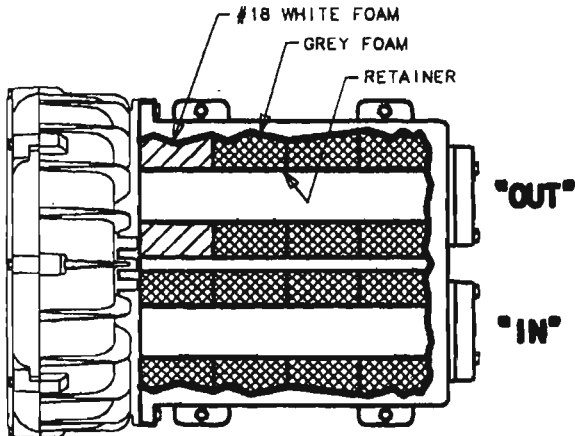

**VIEW - LOOKING DOWN
AT TOP OF BLOWER**
(MOTOR REMOVED FOR CLARITY)

RAIL MOUNT

PUT FINGER GUARD SCREEN, IN BOTH HOUSING MANFOLD CAVITIES. THEN PLACE WHITE FOAM INSERT, IN CAVITIES TO HOLD SCREEN IN PLACE.

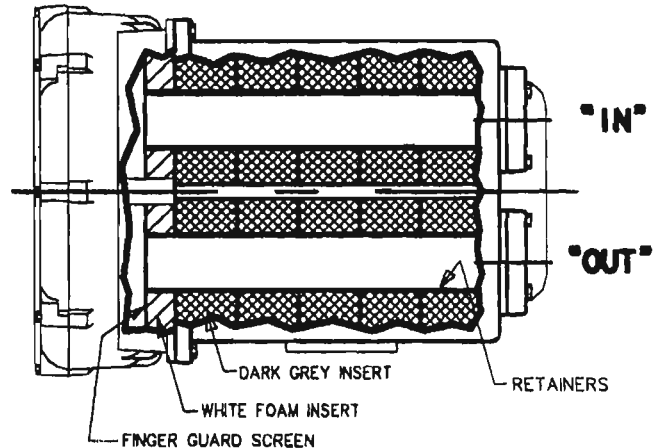

**VIEW - LOOKING DOWN
AT TOP OF BLOWER**
(MOTOR REMOVED FOR CLARITY)