

Tru-Vue™

ML17 Series Tru-Vue™ Sensors

- Cost-effective
- Compact, versatile housing
- 4-in-1 output
- 4 connection options



4 output options from 1 sensor:
NPN normally open, NPN normally closed,
PNP normally open, or PNP normally closed



Diffuse Mode with Background Suppression

See page 404

Features:

- Very low color sensitivity
- Tamper-proof housing with no external adjustments

Sensing Range: 50 mm

Output: 4-in-1

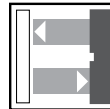

Diffuse Mode

See page 405

Features:

- Sensitivity adjustment for sensing range
- 360° high-visibility LEDs

Sensing Range: 450 mm

Output: 4-in-1

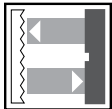

Retro-Reflective Mode

See pages 406-407

Features:

- Polarized and long-range nonpolarized models
- 360° high-visibility LEDs

Sensing Range: 3.5 m, 6.5 m

Output: 4-in-1

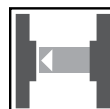

Thru-Beam Mode

See pages 408-409

Features:

- Quick disconnect or cabled versions
- 360° high-visibility LEDs

Sensing Range: 20 m

Output: 4-in-1

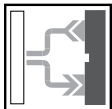

Fiber Optic Diffuse and Thru-Beam Mode

See page 410

Features:

- Quick attachment of plastic fiber cables
- 360° high-visibility LEDs

Sensing Range: Determined by fiber optic cable





Output: 4-in-1

See pages 411-416 for ML17 Series specifications, wiring and dimensions.



Diffuse Mode with Background Suppression

Specifications

SENSING RANGE	10-50 mm	10-50 mm	10-50 mm	10-50 mm
SENSITIVITY ADJUSTMENT	No	No	No	No
BACKGROUND SUPPRESSION	from 65 mm	from 65 mm	from 65 mm	from 65 mm
BLACK/WHITE DIFFERENTIAL*	≤ 10%	≤ 10%	≤ 10%	≤ 10%
REFERENCE TARGET	100 x 100 mm black test card	100 x 100 mm black test card	100 x 100 mm black test card	100 x 100 mm black test card
MODEL NUMBER(S)	ML17-8-H-50-RT/115/136 ⚡	ML17-8-H-50-RT/136/143 •	ML17-8-H-50-RT/73/136 •	ML17-8-H-50-RT/115b/136 ⚡
OUTPUT  /136	4-in-1†	4-in-1†	4-in-1†	4-in-1†
SUPPLY VOLTAGE	10-30 VDC	10-30 VDC	10-30 VDC	10-30 VDC
RESPONSE TIME	≤ 1.0 ms	≤ 1.0 ms	≤ 1.0 ms	≤ 1.0 ms
SWITCHING FREQUENCY	500 Hz	500 Hz	500 Hz	500 Hz
LIGHT SPOT DIAMETER	≤ 3mm at a range of 50 mm	≤ 3mm at a range of 50 mm	≤ 3mm at a range of 50 mm	≤ 3mm at a range of 50 mm
LIGHT BEAM ANGLE	≤ 4°	≤ 4°	≤ 4°	≤ 4°
LIGHT SOURCE	Visible red LED 640 nm	Visible red LED 640 nm	Visible red LED 640 nm	Visible red LED 640 nm
WEIGHT	1.4 oz	0.3 oz	0.3 oz	0.8 oz
ELECTRICAL CONNECTION	 2-meter cable, PVC covered, 4-conductor, #26AWG	 Quick disconnect type V31, integral	 Quick disconnect type V1, integral	 150 mm pigtail, PVC covered, quick disconnect type V1
ADDITIONAL DATA	See pages 411-416			



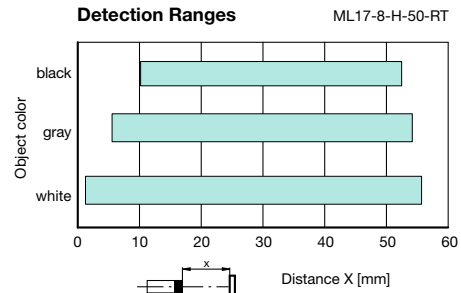
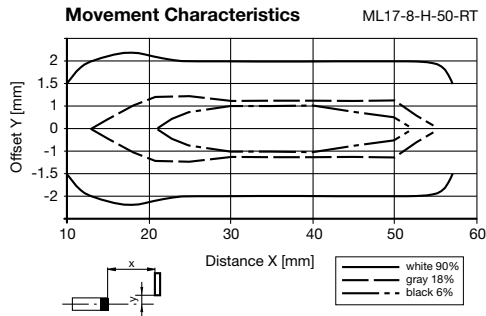

*Difference in sensing range between 90% white test card and 6% black test card.
 †NPN normally open, NPN normally closed, PNP normally open, or PNP normally closed

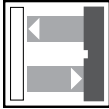
Sensing Characteristics





Diffuse Mode

Specifications				
SENSING RANGE	10-450 mm	10-450 mm	10-450 mm	10-450 mm
SENSITIVITY ADJUSTMENT	Yes	Yes	Yes	Yes
REFERENCE TARGET	100 x 100 mm white test card	100 x 100 mm white test card	100 x 100 mm white test card	100 x 100 mm white test card
MODEL NUMBER(S)	ML17-8-450/115/136 ⚡	ML17-8-450/136/143 •	ML17-8-450/73/136 •	ML17-8-450/115b/136 ⚡
OUTPUT	 /136	4-in-1*	4-in-1*	4-in-1*
SUPPLY VOLTAGE	10-30 VDC	10-30 VDC	10-30 VDC	10-30 VDC
RESPONSE TIME	≤ 1.0 ms	≤ 1.0 ms	≤ 1.0 ms	≤ 1.0 ms
SWITCHING FREQUENCY	500 Hz	500 Hz	500 Hz	500 Hz
LIGHT SOURCE	Infrared LED 950 nm	Infrared LED 950 nm	Infrared LED 950 nm	Infrared LED 950 nm
WEIGHT	1.4 oz	0.3 oz	0.3 oz	0.8 oz
ELECTRICAL CONNECTION	 2-meter cable, PVC covered, 4-conductor, #26AWG	 Quick disconnect type V31, integral	 Quick disconnect type V1, integral	 150 mm pigtail, PVC covered, quick disconnect type V1
ADDITIONAL DATA	See pages 411-416			

*NPN normally open, NPN normally closed, PNP normally open, or PNP normally closed



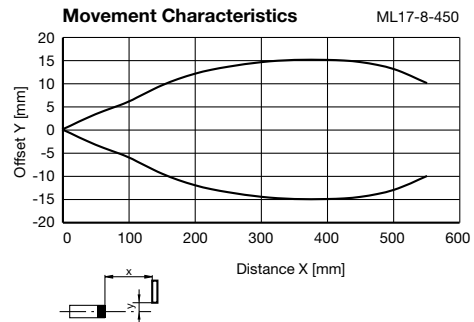
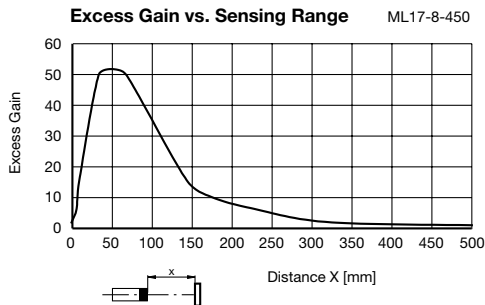

Sensing Characteristics





Retro-Reflective Mode

Specifications

SENSING RANGE	0-3.5 m	0-3.5 m	0-3.5 m	0-3.5 m
SENSITIVITY ADJUSTMENT	Yes	Yes	Yes	Yes
REFERENCE TARGET	FE-RR1 reflector	FE-RR1 reflector	FE-RR1 reflector	FE-RR1 reflector
REFLECTOR DISTANCE	50 mm-3.5 m	50 mm-3.5 m	50 mm-3.5 m	50 mm-3.5 m
POLARIZATION FILTER	Yes	Yes	Yes	Yes
MODEL NUMBER(S)	ML17-54/115/136 ⚡	ML17-54/136/143 •	ML17-54/73/136 ⚡	ML17-54/115b/136 ⚡
OUTPUT  /136	4-in-1*	4-in-1*	4-in-1*	4-in-1*
SUPPLY VOLTAGE	10-30 VDC	10-30 VDC	10-30 VDC	10-30 VDC
RESPONSE TIME	≤ 1.0 ms	≤ 1.0 ms	≤ 1.0 ms	≤ 1.0 ms
SWITCHING FREQUENCY	500 Hz	500 Hz	500 Hz	500 Hz
LIGHT SOURCE	Visible red LED 626 nm	Visible red LED 626 nm	Visible red LED 626 nm	Visible red LED 626 nm
WEIGHT	1.4 oz	0.3 oz	0.3 oz	0.8 oz
ELECTRICAL CONNECTION	 2-meter cable, PVC covered, 4-conductor, #26AWG	 Quick disconnect type V31, integral	 Quick disconnect type V1, integral	 150 mm pigtail, PVC covered, quick disconnect type V1
ADDITIONAL DATA	See pages 411-416			



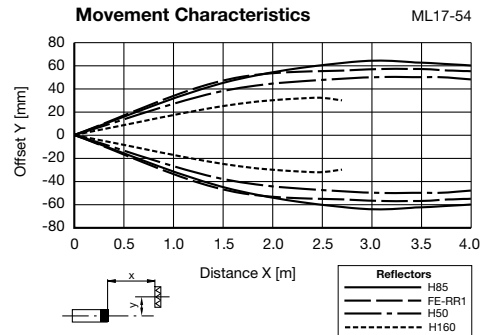
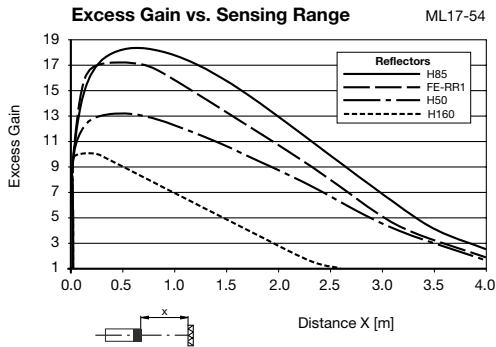

*NPN normally open, NPN normally closed, PNP normally open, or PNP normally closed

Sensing Characteristics





Retro-Reflective Mode

Specifications				
SENSING RANGE	0-6.5 m	0-6.5 m	0-6.5 m	0-6.5 m
SENSITIVITY ADJUSTMENT	Yes	Yes	Yes	Yes
REFERENCE TARGET	FE-RR1 reflector	FE-RR1 reflector	FE-RR1 reflector	FE-RR1 reflector
REFLECTOR DISTANCE	50 mm-6.5 m	50 mm-6.5 m	50 mm-6.5 m	50 mm-6.5 m
POLARIZATION FILTER	No	No	No	No
MODEL NUMBER(S)	ML17-6/115/136 •	ML17-6/136/143	ML17-6/73/136	ML17-6/115b/136 •
OUTPUT  /136	4-in-1*	4-in-1*	4-in-1*	4-in-1*
SUPPLY VOLTAGE	10-30 VDC	10-30 VDC	10-30 VDC	10-30 VDC
RESPONSE TIME	≤ 1.0 ms	≤ 1.0 ms	≤ 1.0 ms	≤ 1.0 ms
SWITCHING FREQUENCY	500 Hz	500 Hz	500 Hz	500 Hz
LIGHT SOURCE	Visible red LED 626 nm	Visible red LED 626 nm	Visible red LED 626 nm	Visible red LED 626 nm
WEIGHT	1.4 oz	0.3 oz	0.3 oz	0.8 oz
ELECTRICAL CONNECTION	 2-meter cable, PVC covered, 4-conductor, #26AWG	 Quick disconnect type V31, integral	 Quick disconnect type V1, integral	 150 mm pigtail, PVC covered, quick disconnect type V1
ADDITIONAL DATA	See pages 411-416			

*NPN normally open, NPN normally closed, PNP normally open, or PNP normally closed

Sensing Characteristics

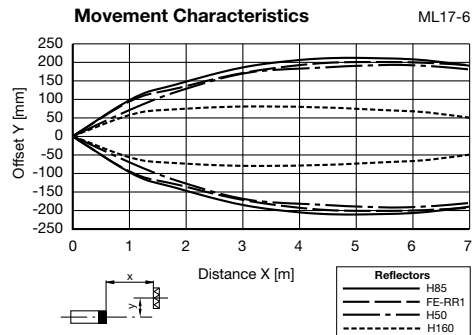
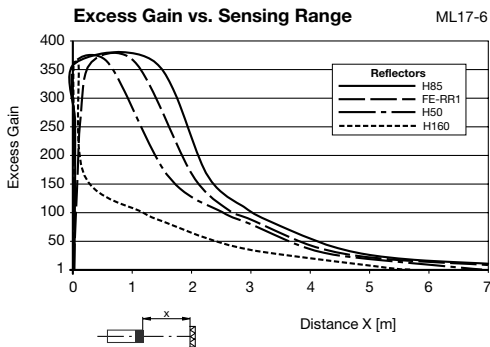

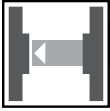

Thru-Beam Mode

Specifications

SENSING RANGE		0-20 m	0-20 m	0-20 m	0-20 m
SENSITIVITY ADJUSTMENT		No	No	No	No
REFERENCE TARGET		Receiver	Receiver	Receiver	Receiver
MODEL NUMBER(S)	Transmitter	MD17/115 ⚡	MD17/143 •	MD17/73 •	MD17/115b ⚡
	Receiver	MV17/115/136 ⚡	MV17/136/143 •	MV17/73/136 •	MV17/115b/136 ⚡
OUTPUT	/136	4-in-1*	4-in-1*	4-in-1*	4-in-1*
SUPPLY VOLTAGE		10-30 VDC	10-30 VDC	10-30 VDC	10-30 VDC
RESPONSE TIME		≤ 3.0 ms	≤ 3.0 ms	≤ 3.0 ms	≤ 3.0 ms
SWITCHING FREQUENCY		150 Hz	150 Hz	150 Hz	150 Hz
LIGHT SOURCE		Infrared LED 950 nm	Infrared LED 950 nm	Infrared LED 950 nm	Infrared LED 950 nm
WEIGHT		1.4 oz (per housing)	0.3 oz (per housing)	0.3 oz (per housing)	0.8 oz (per housing)
ELECTRICAL CONNECTION		2-meter cable, PVC covered, 4-conductor, #26AWG	Quick disconnect type V31, integral	Quick disconnect type V1, integral	150 mm pigtail, PVC covered, quick disconnect type V1
ADDITIONAL DATA		See pages 411-416			

*NPN normally open, NPN normally closed, PNP normally open, or PNP normally closed



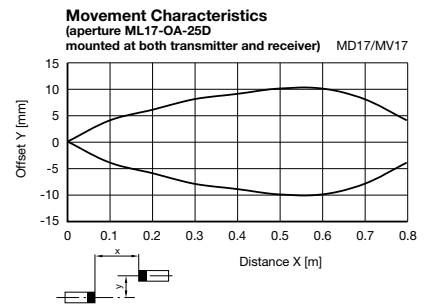
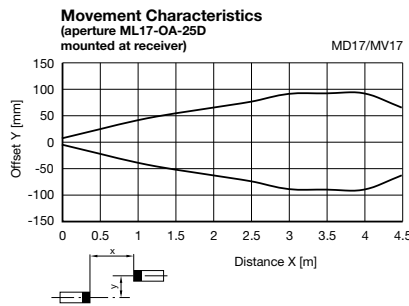
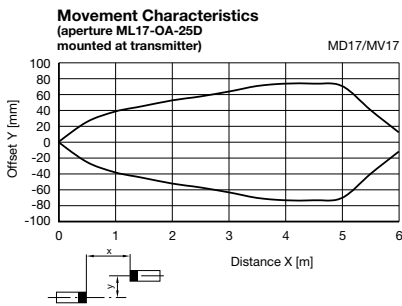
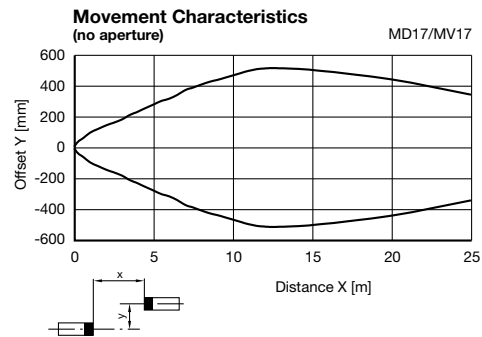
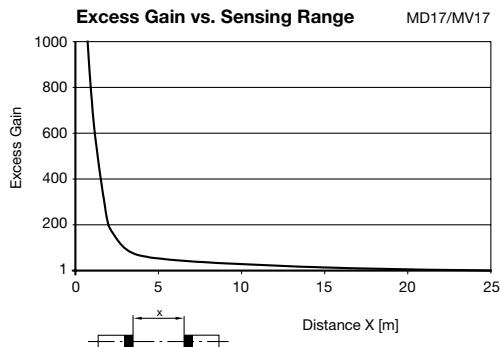

Sensing Characteristics





Fiber Optic Diffuse and Thru-Beam Mode

Specifications

SENSING RANGE	Determined by cable†	Determined by cable†	Determined by cable†	Determined by cable†
SENSITIVITY ADJUSTMENT	Yes	Yes	Yes	Yes
MODEL NUMBER(S)	ML17-LL-K/115/136 ⚡	ML17-LL-K/136/143	ML17-LL-K/73/136 •	ML17-LL-K/115b/136 •
OUTPUT  /136	4-in-1*	4-in-1*	4-in-1*	4-in-1*
SUPPLY VOLTAGE	10-30 VDC	10-30 VDC	10-30 VDC	10-30VDC
RESPONSE TIME	≤ 1.0 ms	≤ 1.0 ms	≤ 1.0 ms	≤1.0ms
SWITCHING FREQUENCY	500 Hz	500 Hz	500 Hz	500Hz
LIGHT SOURCE	Visible red LED 670 nm	Visible red LED 670 nm	Visible red LED 670 nm	Visible red LED 670nm
WEIGHT	1.4 oz	0.3 oz	0.3 oz	0.8oz
ELECTRICAL CONNECTION	 2-meter cable, PVC covered, 4-conductor, #26AWG	 Quick disconnect type V31, integral	 Quick disconnect type V1, integral	 150 mm pigtail, PVC covered, quick disconnect type V1
ADDITIONAL DATA	See pages 411-416			

*NPN normally open, NPN normally closed, PNP normally open, or PNP normally closed

Attaching Fiber Optic Cables to ML17-LL Series

1. With a small flat screwdriver, turn the lock located on the sensor face counter-clockwise to the unlocked position.
2. Insert a standard 2.2mm diameter fiber optic cable into the housing until the cable goes no farther. For 1mm diameter cables, insert fiber ends into the adapter and then slide the adapter into the sensor until it stops.
3. Turn lock clockwise to lock the fibers.

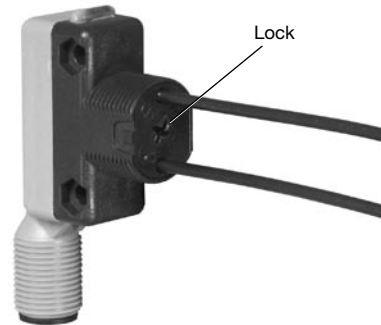

†See pages 761-796 for fiber optic lengths and specifications.



Series Specifications

ML17 Series Specifications

LOAD CURRENT	100 mA max. per output
LEAKAGE CURRENT	≤ 100 µA per output
VOLTAGE DROP	≤ 2.5 VDC
SHORT CIRCUIT AND OVERLOAD PROTECTION	Yes
REVERSE POLARITY PROTECTION	Yes
VOLTAGE RIPPLE	± 10%
LED(s)	Yes (2) (1 for MD17)*
CURRENT CONSUMPTION	≤ 25 mA; ≤ 30 mA for ML17-8-H
OPERATING MODE	Light on/dark on
READINESS DELAY	≤ 100 ms
PROTECTION (IEC)	IP67
AMBIENT LIGHT RESISTANCE	≤ 10,000 lux
TEMPERATURE RANGE	<i>WORKING</i> -4 °F to +131 °F
	<i>STORAGE</i> -4 °F to +167 °F
HOUSING MATERIAL	ABS
	<i>LENS</i> Acrylic
APPROVALS	CE c UL US

*See dimensional drawings for LED functions.

Wiring Diagrams

DC



Cable Connection

Normally Open

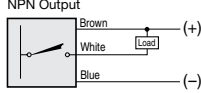

Normally Closed

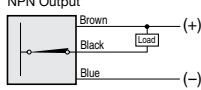

Normally Open

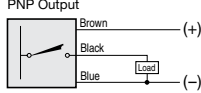

Normally Closed

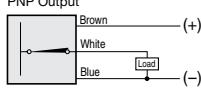

Transmitter

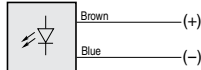

Quick Disconnect

Note: Wiring diagrams show quick disconnect pin numbers.

V1 Type

Normally Open

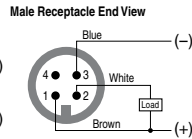
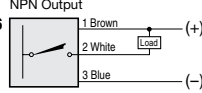

Normally Closed

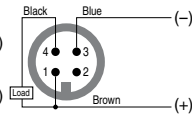
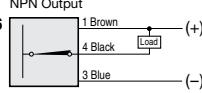

Normally Open

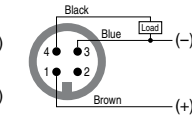
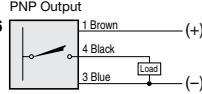

Normally Closed

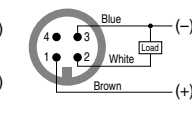
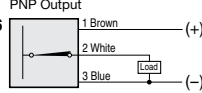

Transmitter

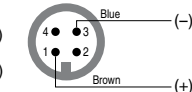
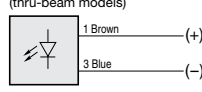

V31 Type

Normally Open

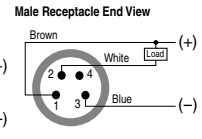
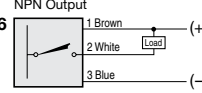

Normally Closed

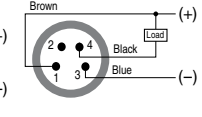
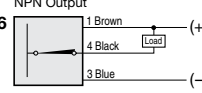

Normally Open

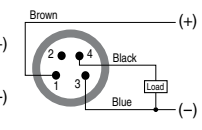
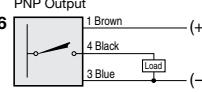

Normally Closed

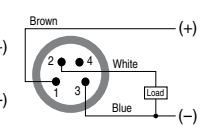
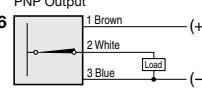

Transmitter

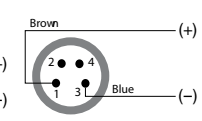

4-in-1 Output

The 4-in-1 output offers one normally open and one normally closed output, both of which automatically detect the connected load, so the outputs either source or sink current depending on the load. A single sensor can operate as NPN normally open, NPN normally closed, PNP normally open, or PNP normally closed.



See pages 803-854 for cordsets



See pages 797-802 for reflectors



See pages 865-872 for additional accessories



See pages 761-796 for fiber optic lengths and specifications.

Dimensions (mm)

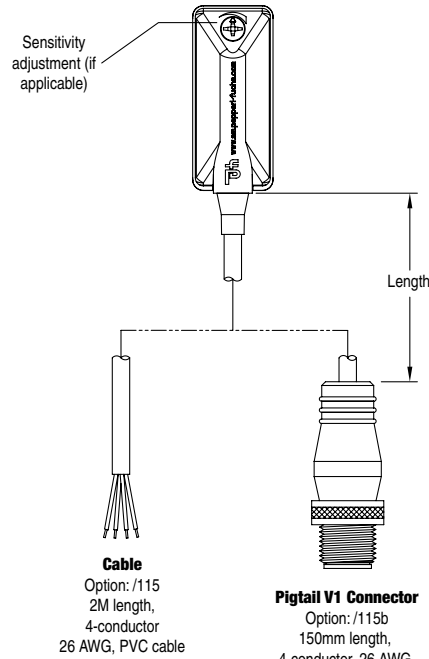
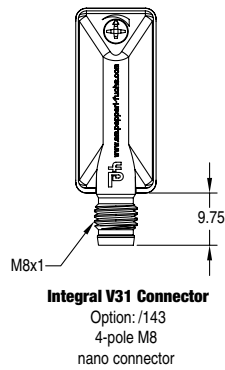
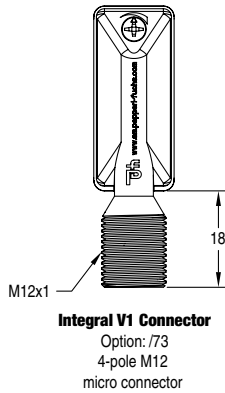
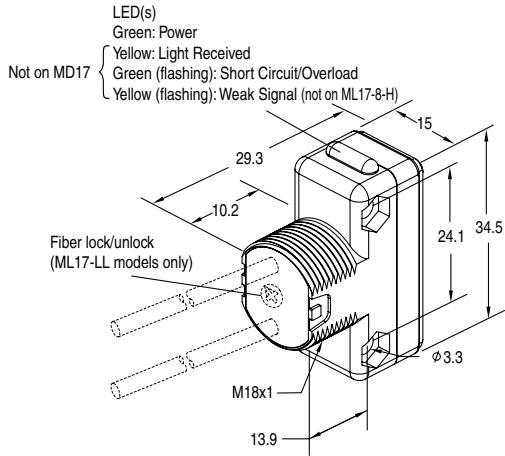

Accessories

(Dimensions in mm)

Snout-mount Mounting Bracket Model OMH-ML17
 for ML17 Series sensors

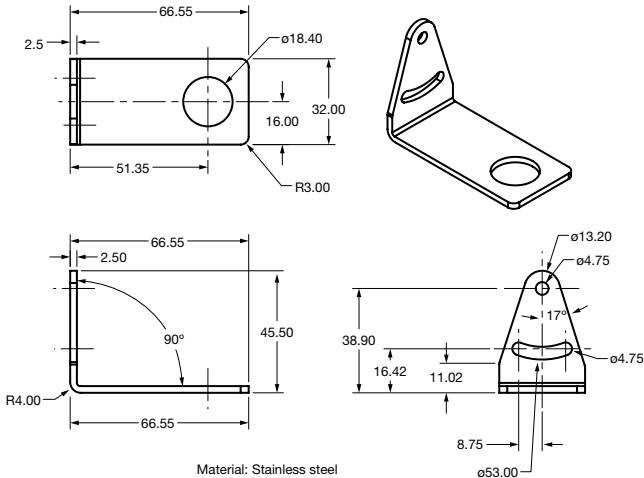

Side-mount Mounting Bracket Model OMH-ML17-1
 for ML17 Series sensors

