

Dimensions

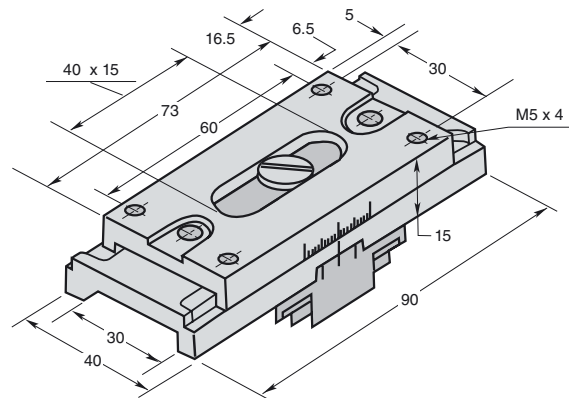

Model Number

MH4-2681 UNI

Mounting aid

Features

- Adjustable Unistrut bracket
- For use with limit switch style sensors

Technical data

Mechanical specifications

Material	metal Diecast zinc
----------	-----------------------

Note

Mounting Instructions

Example 1: Position bracket on Unistrut and lock in place with snap lock screw. Then back off snap lock screw slightly to allow movement of the bracket on the Unistrut. Mount and fasten the sensor loosely with two M5 x 20 mm screws using the elongated holes. Then screw the headless screws into the round holes.

Align in the desired position, tighten screws to hold the sensor firmly in place. Sensor can be removed from the mounting bracket without affecting sensing range adjustment by removing the two M5 x 20 mm screws and lifting sensor up and over the two headless screws. To remount the sensor, simply slide the sensor onto the two headless screws and fasten the sensor tightly using the two M5 x 20 mm screws through elongated holes.

Example 2: Position bracket on Unistrut and lock in place with snap lock screw. Then back off snap lock screw slightly to allow movement of the bracket on the Unistrut. Mount and fasten the sensor loosely with the mounting screws (M5 x 20 mm). Align in desired position and tighten the four mounting screws to hold the sensor firmly in place.