

THIS DRAWING IS UNPUBLISHED. RELEASED FOR PUBLICATION
 © COPYRIGHT - By - ALL RIGHTS RESERVED.

LOC	DIST	REVISIONS					
FT	0	P	LTR	DESCRIPTION	DATE	DWN	APVD
		AB2		REVISED PER ECO-14-008433	05JUN2014	NK	MZ

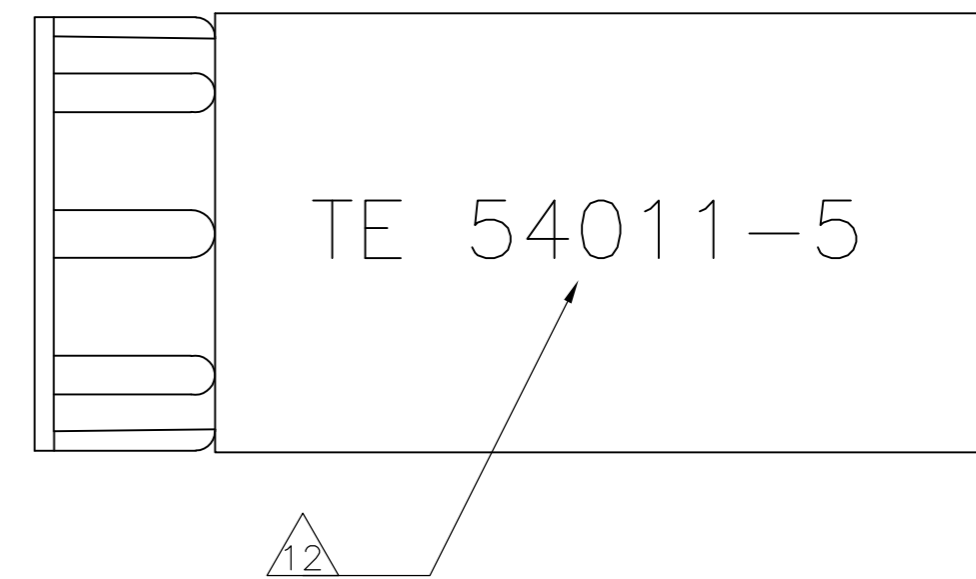
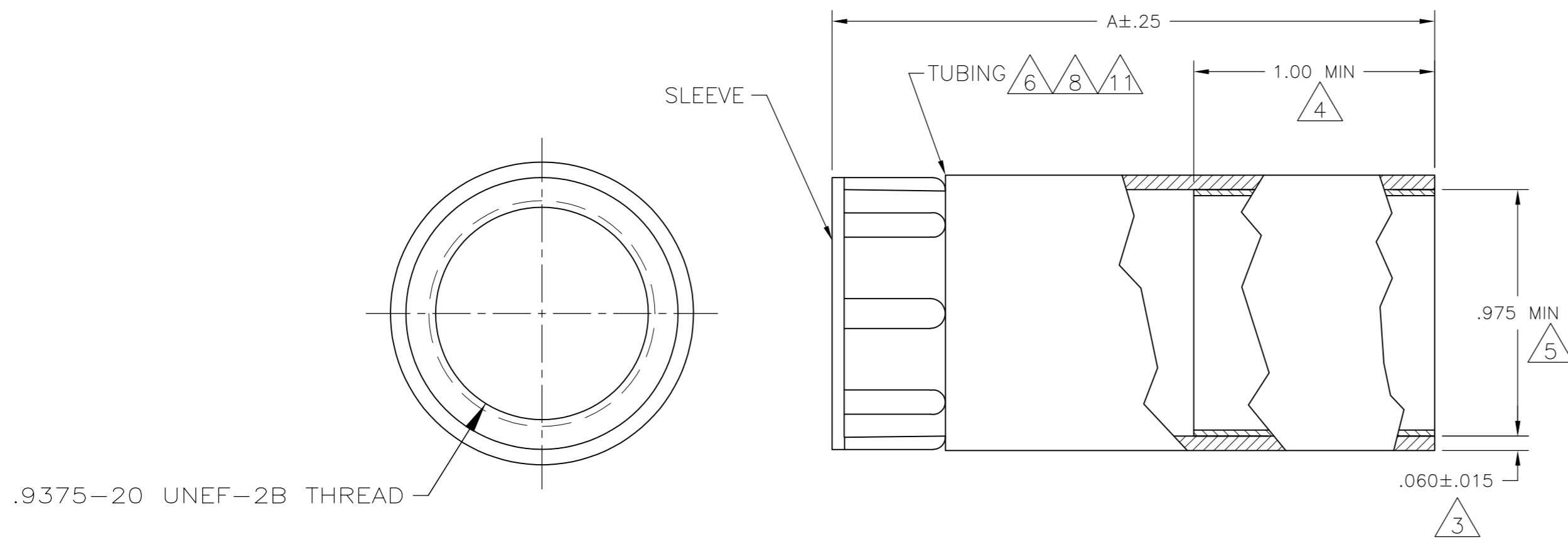

MARKING DETAIL

- 1 POLYOLEFIN, BLACK.
- 2 NYLON, BLACK.
- 3 NOMINAL WALL THICKNESS, EXPANDED.
- 4 LENGTH OF SEALANT.
- 5 EXPANDED INSIDE DIAMETER.
- 6 9.52[.375] MAXIMUM RECOVERED INSIDE DIAMETER.
- 7 ASSEMBLY WILL PASS 0.0703 KG PER SQ CENTIMETER [ONE POUND PER SQ IN.] WATER PRESSURE TEST.
- 8 121°C [250°F] SHRINK TEMPERATURE.
- 9 -55°C TO 110°C [-67°F TO 230°F] OPERATING TEMPERATURE.
- 10 THIS PART WILL ACCOMMODATE $\phi 10.16 - \phi 22.22$ [$\phi 400 - \phi .875$] CABLE RANGE.
- 11 ACTUAL SHAPE MAY VARY DUE TO PROCESS VARIANCE.
- 12 SEE P/N CHART FOR MARKING. WHITE CHARACTERS .150 MIN HIGH AND LOCATED ON THE OUTSIDE SURFACE OF THE TUBING.
- 13 PRELIMINARY - NOT FOR PRODUCTION.

TE 54011-5	2.50	13 54011-5
NONE	4.00	54011-4
NONE	3.25	54011-3
NONE	2.50	54011-1
MARKING	A	PART NUMBER

THIS DRAWING IS A CONTROLLED DOCUMENT.		DWN	C.REIFSNYDER	10 APR 96				
DIMENSIONS: INCHES		CHK	R.STONE	15 APR 95				
TOLERANCES UNLESS OTHERWISE SPECIFIED:		APVD	T.A.WETZEL	03 MAY 96	NAME			
0 PLC ± -		PRODUCT SPEC	STRAIN RELIEF ASSY, SHELL SIZE 17, CPC					
1 PLC ± -		APPLICATION SPEC	SIZE					
2 PLC ± -		WEIGHT	CAGE CODE					
3 PLC ± -		FINISH	DRAWING NO					
4 PLC ± -			RESTRICTED TO					
ANGLES ± -			A2 00779 C=54011					
MATERIAL TUBING: 1 SLEEVE: 2		CUSTOMER DRAWING	SCALE	2:1	SHEET	1 of 1	REV	AB2