



Series *NCG/CG1*

Air Cylinder



- Repairable round body cylinder allowing high-speed operation up to 40in/sec
- Available in 8 bore sizes and 8 different mounting styles
- Removable rod covers allows for easy seal replacement
- Hard anodized aluminum tube cover
- Band-mounted auto switch allows easy position adjustment
- Threaded holes for trunnion style mounting
- Mounting brackets are designed to withstand reaction forces from cylinder, ensuring long life
- Urethane bumpers available as standard
- Engineered piston seal resists rolling











Air Cylinder

Series NCG/CG1

ø20, ø25, ø32, ø40, ø50, ø63, ø80, ø100

Series Variations

Series	Action	Rod	Cushion	Basic	Standard variations					Bore size (mm)	Page
					Built-in One-touch fittings	With rod boot	Air-hydro	Clean series	Copper-free		
Standard Series NCG 	Double acting	Single rod	Rubber	•						20 to 63	4
		Double rod	Rubber	•							25
Standard Series CG1 	Double acting	Single rod	Rubber	•	•	•	•	•	•	20 to 100	4
		Double rod	Rubber	•	•	•	•	•	•		25
Standard Series NCG/CG1 	Single acting	Single rod (Spring return/Spring extend)	Rubber	•						20 to 40	34
Non-rotating Rod Series NCGK 	Double acting	Single rod	Rubber	•						20 to 63	44
Non-rotating Rod Series CG1K 	Double acting	Single rod	Rubber	•				•		20 to 63	44
			Air	•						40 to 63	
		Double rod	Rubber	•							20 to 63
Direct Mount Series CG1R 	Double acting	Single rod	Rubber	•				•	•	20 to 63	53
Low Friction Series CG1□Q 	Double acting	Single rod	Without (ø20 to ø32) Rubber (ø40 to ø100)	•						20 to 100	62
With End Lock Series CBG1 	Double acting	Single rod	Rubber	•		•				20 to 100	68
			Air	•		•					

Air Cylinder: Standard Type Double Acting, Single Rod

Series *NCG/CG1*

ø20, ø25, ø32, ø40, ø50, ø63, ø80, ø100

How to Order

Without auto switch

NCG L N 25 — 04 00

With auto switch

NCDG L N 25 — 04 00 — M9NW

Built-in magnet

Mounting style

B	Basic style	U	Front trunnion style
C	Single clevis	T	Rear trunnion style
L	Axial foot style	D	Double Clevis style
F	Front flange style	N*	Front nose mount
G	Rear flange style		

*Nose mount with air cushion is not available in ø20 and ø25mm.

Cushion

N	Urethane cushion
A	Adjustable air cushion

*Nose mount with air cushion is not available in ø20 and ø25mm.

Bore size

20	20 mm (3/4")	40	40 mm (1-1/2")
25	25 mm (1")	50	50 mm (2")
32	32 mm (1-1/4")	63	63 mm (2-1/2")

Number of auto switches

Nil	2 pcs.
S	1 pc.
n	"n" pcs.

Auto switch

Nil	Without auto switch (Built-in magnet)
------------	---------------------------------------

*For the applicable auto switch model, refer to the table below.

Stroke
Hundredths of an inch*

*Stroke length must be indicated as 4 digits.
First and second digit: Stroke/Inch
Third and fourth digit: Stroke/Hundredth of an inch
Example) 0525=5.25 (5-1/4) inch stroke

Cylinder stroke (inch)



How to Order

Without auto switch

CG1 L N 25 — 40

With auto switch

CDG1 L N 25 — 40 — M9NW

Built-in magnet

Mounting style

B	Basic style	U*	Front trunnion style
L	Axial foot style	T*	Rear trunnion style
F	Front flange style	D	Double Clevis style
G	Rear flange style	R*	Direct mount

*Not available for bore size ø80 and ø100mm.
Note) Mounting brackets are shipped together, but not assembled.

Cushion

N	Urethane cushion
A	Adjustable air cushion

Bore size

20	20 mm	50	50 mm
25	25 mm	63	63 mm
32	32 mm	80	80 mm
40	40 mm	100	100 mm

Number of auto switches

Nil	2 pcs.
S	1 pc.
n	"n" pcs.

Auto switch

Nil	Without auto switch (Built-in magnet)
------------	---------------------------------------

*For the applicable auto switch model, refer to the table below.

Rod boot

Nil	Without rod boot
J	Nylon tarpaulin
K	Heat resistant tarpaulin

Cylinder stroke (mm)

Applicable Auto Switch/Refer to Best Pneumatics for further information on auto switches.

Type	Special function	Electrical entry	Indicator light	Wiring (Output)	Load voltage		Auto switch model		Lead wire length (m) *				Pre-wire connector	Applicable load		
					DC	AC	Applicable bore size (mm)		0.5 (Nil)	3 (L)	5 (Z)	None (N)		IC circuit	Relay, PLC	
							20 to 63	80, 100								
Reed switch	—	Grommet	Yes	3-wire (NPN equivalent)	—	5 V	—	C76	—	●	●	—	—	—	—	—
				2-wire	24 V	—	100 V, 200 V	B54		●	●	●	—	—	—	—
	100 V	C73					—	●	●	●	—	—				
	C73C	—		●	●	●	●	—	—							
Diagnostic indication (2-color indication)	Grommet	—	—	B59W		●	●	—	—	—	—					
Solid state switch	—	Grommet	Yes	3-wire (NPN)	24 V	5 V, 12 V	—	M9N	G59	●	—	○	—	○	IC circuit	Relay, PLC
				3-wire (PNP)				M9P	G5P	●	—	○	—	○		
	2-wire			M9B				K59	●	—	○	—	○			
	3-wire (NPN)			M9NW				G59W	●	●	○	—	○			
	3-wire (PNP)			M9PW				G5PW	●	●	○	—	○			
	2-wire			M9BW				K59W	●	●	○	—	○			
	Water resistant (2-color indication)			M9BA				G5BA	●	●	○	—	○			
	Diagnostic output (2-color indication)			—				G59F	●	●	○	—	○			

* Lead wire length symbols: 0.5 m..... Nil (Example) C73C M9NW
 3 m..... L (Example) C73CL M9NL
 5 m..... Z (Example) C73CZ M9NZ
 None..... N (Example) C73CN

* Solid state switches marked with "○" are produced upon receipt of order.

- Since there are other applicable auto switches than listed, contact SMC for details.
- For details about auto switches with pre-wire connector, refer to Best Pneumatics.



Series NCG/CG1

Substantially shorter length:

ø20 to ø40... -15 to -30 mm
(in comparison with Series CM2)
ø40 to ø63... -17 to -28 mm
(in comparison with Series CA1)
ø80, ø100... -9 to -33 mm
(in comparison with Series CA1)

High speed operation:

1000 mm/s

(ø80 and ø100 operate at 700 mm/s)

Air cushion standardized

Two cushions are available:
air cushion or rubber bumper

Weight reduction of 10 to 50%

(50 mm stroke, in-house comparison)

Highly accurate mounting brackets

(Axial foot style, Rod side frange style)

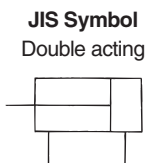

Specifications

Bore size (mm)	20	25	32	40	50	63	80	100
Action	Double acting, Single rod							
Type	Non-lube							
Fluid	Air							
Proof pressure	215 psi (1.5 MPa)							
Maximum operating pressure	145 psi (1.0 MPa)							
Minimum operating pressure	8 psi (0.05 MPa)							
Ambient and fluid temperature	Without auto switch: 14 to 158°F [-10 to 70°C] (No freezing) With auto switch: 14 to 140°F [-10 to 60°C] (No freezing)							
Piston speed	2 to 40 inch/sec (50 to 1000mm/s)						2 to 28 inch/sec (50 to 700 mm/s)	
Stroke length tolerance	Up to 1000 ^{st+1.4} ₀ mm, Up to 1200 ^{st+1.4} ₀ mm						Up to 1000 ^{st+1.4} ₀ mm Up to 1500 ^{st+1.8} ₀ mm	
Thread tolerance	JIS Class 2							
Cushion	Rubber bumper, Air cushion							
Mounting	Basic style, Axial foot style, Rod side flange style, Head side flange style, Rod side trunnion style, ⁽¹⁾ Head side trunnion style ⁽¹⁾ , Clevis style, Nose mount ⁽²⁾ (Used for changing the port location by °90.)							

Note1) Rod/Head side trunnion styles are not available for bore sizes ø80 and ø100.

Note 2) Nose mount only available for Series NCG.

Accessory

Mounting		Basic style	Axial foot style	Rod side flange style	Head side flange style	Rod side trunnion style	Head side trunnion style	Clevis style	Nose mount
Standard equipment	Rod end nut	●	●	●	●	●	●	●	●
	Clevis pin	—	—	—	—	—	—	●	—
Option	Single knuckle joint	●	●	●	●	●	●	●	●
	Double knuckle joint (With pin)	●	●	●	●	●	●	●	●
	Pivot bracket	●	—	—	—	●*	●*	●	—
	Rod boot	●	●	●	●	●	●	●	—

* Trunnion bracket is not available for ø80 and ø100.

** Pin and snap ring are shipped together with double knuckle joint.



Made to Order Specifications

Symbol	Specifications	NCG	CG1
-XA□	Change of rod end shape	●	●
-XB6	Heat resistant cylinder (302°F [150°C])	●	●
-XB7	Cold resistant cylinder	●	●
-XB13	Low speed cylinder (5 to 50 mm/s)	●	●
-XC4	With heavy duty scraper	●	●
-XC6	Piston rod and rod end nut made of stainless steel	●	●
-XC8	Adjustable stroke cylinder/Adjustable extension type	●	●
-XC9	Adjustable stroke cylinder/Adjustable retraction type	●	●
-XC10	Dual stroke cylinder/Double rod type	●	●
-XC11	Dual stroke cylinder/Single rod type	●	●
-XC12	Tandem type cylinder		●
-XC13	Auto switch rail mounting style		●
-XC18	NPT finish piping port		●
-XC20	Head cover axial port		●
-XC22	Fluoro rubber seals		●
-XC29	Double knuckle joint with spring pin		●
-XC35	With coil scraper		●
-XC37	Larger throttle diameter of connecting port	●	●
-XC42	Built-in rear shock absorber		●

Standard Stroke (for CG1)

Bore size (mm)	Standard stroke ⁽¹⁾ (mm)	Long stroke (mm)	Maximum manufacturable stroke (mm)
20	25, 50, 75, 100, 125, 150, 200	201 to 350	1500
25		301 to 400	
32		301 to 450	
40	25, 50, 75, 100, 125, 150, 200, 250, 300	301 to 800	
50, 63		301 to 1200	
80		301 to 1400	
100		301 to 1500	

Standard Stroke (for NCG)

Bore size (mm)	Standard stroke ⁽¹⁾ (inch)	Long stroke (inch)	Maximum manufacturable stroke (inch)
20	1, 2, 3, 4, 5, 6, 8	20	59
25		25	
32		40	
40	1, 2, 3, 4, 5, 6, 8, 10, 12	45	
50		55	
63		55	

Note1) Other intermediate strokes can be manufactured upon receipt of an order. Spaces are not used for the intermediate strokes.

Note2) Long stroke applies to the axial foot style and the rod side flange style. If other length exceeds the stroke limit, the stroke should be determined based on the stroke selection table in the technical data.

Rod Boot Material

Symbol	Rod boot material	Maximum operating temperature
J	Nylon tarpaulin	70°C
K	Heat resistant tarpaulin	110°C *

* Maximum ambient temperature for the rod boot itself.

NCG Mounting Bracket Part No.

Mounting bracket	Cylinder nominal size inch (Bore size mm)					
	3/4" (20)	1" (25)	1-1/4" (32)	1-1/2" (40)	2" (50)	2-1/2" (63)
Foot	NCG-L020	NCG-L025	NCG-L032	NCG-L040	NCG-L050	NCG-L063
Flange	NCG-F020	NCG-F025	NCG-F032	NCG-F040	NCG-F050	NCG-F063
Trunnion	NCG-T020	CG-T025	CG-T032	NCG-T040	NCG-T050	NCG-T063
Trunnion bracket	NCG-P020	NCG-P025	NCG-P032	NCG-P040	NCG-P050	NCG-P063
Double clevis	NCG-D020	NCG-D025	NCG-D032	NCG-D040	NCG-D050	NCG-D063
Single clevis	NCG-C020	NCG-C025	NCG-C032	NCG-C040	NCG-C050	NCG-C063

CG1 Mounting Bracket Part No.

Mounting bracket	Bore size (mm)							
	20	25	32	40	50	63	80	100
Axial foot ⁽¹⁾	CG-L020	CG-L025	CG-L032	CG-L040	CG-L050	CG-L063	CG-L080	CG-L100
Flange	CG-F020	CG-F025	CG-F032	CG-F040	CG-F050	CG-F063	CG-F080	CG-F100
Trunnion pin	CG-T020	CG-T025	CG-T032	CG-T040	CG-T050	CG-T063	—	—
Clevis ⁽²⁾	CG-D020	CG-D025	CG-D032	CG-D040	CG-D050	CG-D063	CG-D080	CG-D100
Pivot bracket	CG-020-24A	CG-025-24A	CG-032-24A	CG-040-24A	CG-050-24A	CG-063-24A	CG-080-24A	CG-100-24A

Note 1) Order two foot brackets per cylinder.

Note 2) Clevis pin, snap ring and mounting bolt are shipped together with clevis style.

Note 3) Mounting bolts are shipped together for foot style and flange style.

Auto Switch Mounting Bracket Part No.

Auto switch model	Bore size (mm)							
	20	25	32	40	50	63	80	100
D-C7/C8	BMA2-020	BMA2-025	BMA2-032	BMA2-040	BMA2-050	BMA2-063	—	—
D-B5/B6	BA-01	BA-02	BA-32	BA-04	BA-05	BA-06	BA-08	BA-10
D-G5/K5								
D-M9	BMA2-020	BMA2-025	BMA2-032	BMA2-040	BMA2-050	BMA2-063	—	—
BJ3-1 (Adaptor piece)								



* Mounting screws set made of stainless steel

The following set of mounting screws made of stainless steel is also available. Use it in accordance with the operating environment.

(A switch mounting band is not included, so please order it separately.)

Minimum Stroke for Auto Switch Mounting

Model	No. of auto switches mounted	
	2	1
D-C7/C8 D-B5/B6 D-M9 D-G5/K5	15 mm	10 mm
D-B59W	20 mm	15 mm

Model	Bore size (mm)	No. of auto switches mounted	
		2	1
D-G5NBL	20	50 mm	30 mm
	25	55 mm	35 mm
	32		
	40	65 mm	
	50		
	63		
	80		
100	70 mm	40 mm	

Series NCG/CG1

Weight

(kg)

Bore size (mm)		20	25	32	40	50	63	80	100
Basic weight	Basic style	0.10	0.17	0.26	0.41	0.77	1.07	2.04	3.17
	Axial foot style	0.21	0.30	0.42	0.63	1.25	1.79	3.00	4.92
	Flange style	0.18	0.27	0.40	0.61	1.11	1.57	2.75	4.52
	Trunnion style	0.11	0.19	0.29	0.46	0.91	1.21	—	—
	Clevis style	0.15	0.25	0.41	0.64	1.17	1.75	2.75	4.45
Pivot bracket		0.08	0.09	0.17	0.25	0.44	0.80	0.98	1.75
Single knuckle joint		0.05	0.09	0.09	0.10	0.22	0.22	0.39	0.57
Double knuckle joint (With pin)		0.05	0.09	0.09	0.13	0.26	0.26	0.64	1.31
Additional weight per each 50 mm of stroke		0.05	0.07	0.09	0.15	0.22	0.26	0.35	0.49
Additional weight with air cushion		0.01	0.01	0.02	0.02	0.03	0.03	0.03	0.03
Additional weight for long stroke		0.01	0.01	0.02	0.03	0.06	0.10	0.19	0.26

Calculation: (Example) CG1LA20-100 (Foot style, ø20, 100 st)

- Basic weight..... 0.21 (Foot, ø20)
- Additional weight..... 0.05/50 stroke
- Cylinder stroke..... 100 stroke
- Additional weight by air cushion.....0.01 kg

$$0.21 + 0.05 \times 100/50 + 0.01 = 0.32 \text{ kg}$$

Mounting Procedure

Mounting procedure for trunnion

Follow the procedures below when mounting a pivot bracket on the trunnion.

ø20 to ø63

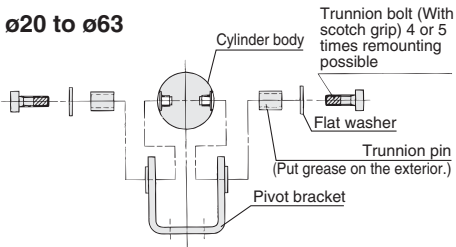

Mounting procedure for clevis

Follow the procedures below when mounting a pivot bracket on the clevis style.

ø20 to ø63

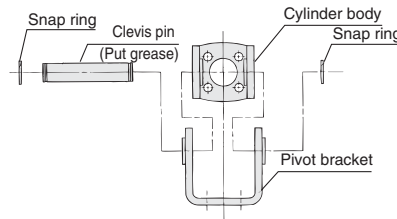

ø80, ø100

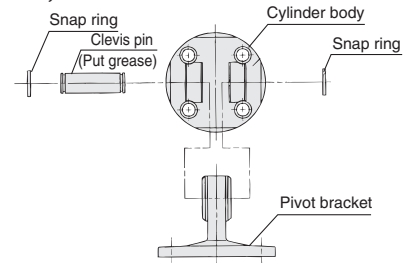

Built-in One-touch Fittings

CG1 **Mounting style** N **Bore size** F — **Stroke**

↓
Built-in
One-touch fittings

This type has the One-touch fitting integrated in a cylinder, which enables to reduce the piping labor and installing space dramatically.

Specifications

Bore size (mm)	20, 25, 32, 40, 50, 63
Action	Double acting
Fluid	Air
Maximum operating pressure	1.0 MPa
Minimum operating pressure	0.05 MPa
Piston speed	50 to 750 mm/s
Cushion	Rubber bumper
Mounting	Basic style, Axial foot style, Rod side flange style Head side flange style, Rod side trunnion style Head side trunnion style, Clevis style (Used for changing the port location by °90.)

* Auto switch can be mounted.

Applicable Tubing O.D./I.D.

Bore size (mm)	20	25	32	40	50	63
Applicable tubing O.D. (mm)	6/4	6/4	6/4	8/6	10/7.5	10/7.5
Applicable tubing material	Can be used for either nylon, soft nylon or polyurethane tubing.					

* For other specifications, refer to Best Pneumatics.

Clean Series

10-CG1 **Mounting style** N **Bore size** — **Stroke**

↓
Clean series (With relief port)

The type which is applicable for using inside the clean room graded Class 100 by making an actuator's rod section a double seal construction and discharging by relief port directly to the outside of clean room.

Specifications

Bore size (mm)	20, 25, 32, 40, 50, 63, 80, 100
Action	Double acting
Fluid	Air
Maximum operating pressure	1.0 MPa
Minimum operating pressure	0.05 MPa
Cushion	Rubber bumper
Piston speed	50 to 400 mm/s
Relief port size	M5 x 0.8
Mounting	Basic style, Axial foot style, Rod side flange style Head side flange style

* Auto switch can be mounted.

For details, refer to the separate catalog, "Pneumatic Clean Series".

Air-hydro

CG1 **Mounting style** H **Bore size** — **Stroke**

↓
Air-hydro

Low pressure hydraulic cylinder of 1.0 MPa or less
When used together with a Series CC air-hydro unit, constant and low speed actuation and intermediate stopping similar to hydraulic units are possible with the use of valves and other pneumatic equipment.

Specifications

Type	Air-hydro
Bore size (mm)	20, 25, 32, 40, 50, 63
Action	Double acting
Fluid	Turbine oil
Proof pressure	1.5 MPa
Maximum operating pressure	1.0 MPa
Minimum operating pressure	0.18 MPa
Piston speed	15 to 300 mm/s
Cushion	None
Ambient and fluid temperature	5 to 60°C
Thread tolerance	JIS Class 2
Stroke length tolerance	Up to 1000 ^{st+1.4} mm, Up to 1200 ^{st+1.8} mm
Mounting	Basic style, Axial foot style, Rod side flange style Head side flange style, Rod side trunnion style Head side trunnion style, Clevis style (Used for changing the port location by °90.)

* Auto switch can be mounted.

Copper-free

20-CG1 **Mounting style** **Type** **Bore size** — **Stroke**

↓
Copper-free

The type which prevents copper based ions from generating by changing the copper based materials into electroless nickel plated treatment or non-copper materials in order to eliminate the effects by copper based ions or fluororesins over the color cathode ray tube.

Specifications

Bore size (mm)	20, 25, 32, 40, 50, 63, 80, 100	
Action	Double acting	
Fluid	Air	
Maximum operating pressure	1.0 MPa	
Minimum operating pressure	0.05 MPa	
Cushion	Type N	Rubber bumper
	Type A	With air cushion
Piston speed	ø20 to 63	50 to 1000 mm/s
	ø80/100	50 to 700 mm/s
Mounting *	Basic style, Axial foot style, Rod side flange style Head side flange style, Rod side trunnion style Head side trunnion style, Clevis style (Used for changing the port location by °90.)	

* Rod/Head side trunnion styles are not available for bore sizes ø80 and ø100.

Dimensions are the same as double acting single rod, standard type.

* Auto switch can be mounted.

Series NCG/CG1

Water Resistant

CG1	Mounting style	Style	Bore size	R	Stroke	G5BAL	-XC6
							Made to order specifications
							Water resistant 2-color indication, Solid state switch
Water resistant cylinder							
R	NBR seals (Nitrile rubber)						
V	FKM seals (Fluoro rubber)						

Failure to do so will damage the cylinder and the seals.
Applicable for use in an environment with water splashing such as food processing and car wash equipment, etc.

Specifications

Action	Double acting, Single rod
Bore size (mm)	32, 40, 50, 63, 80, 100
Cushion	Rubber bumper/Air cushion
Auto switch mounting	Band mounting style
Made to order	Piston rod/Rod end nut material: Stainless steel (-XC6)

* Specifications other than above are the same as standard, basic style.

Dimensions

With rubber bumper

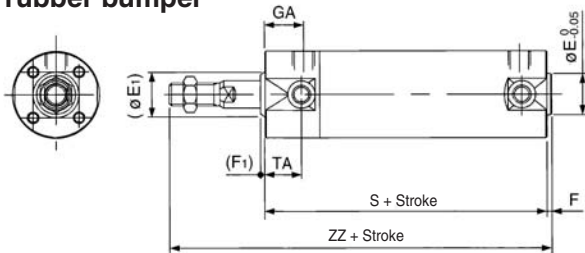

With air cushion

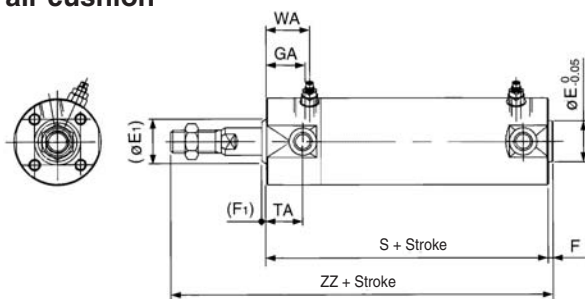

Bore size (mm)	(E1)	E*	(F1)	F*	GA	S	TA	WA	ZZ
32	17	18	2	2	18	77(85)	17	22	119(127)
40	21	25	2	2	19	84(93)	18	22	136(145)
50	26	30	2	2	21	97(109)	20	25	157(169)
63	26	32	2	2	21	97(109)	20	25	157(169)
80	32	40	3	3	28	116(130)	—	30	190(204)
100	37	50	3	3	29	117(131)	—	31	191(205)

*These dimensions and other dimensions not indicated here are the same as standard.

*(): Denotes the dimensions for long stroke.

For detailed specifications, refer to the separate catalog (CAT. E244C).

⚠ Precautions

Be sure to read before handling. Refer Best Pneumatics for Safety Instructions and Actuator Precautions.

Operating Precautions

⚠ Warning

1. Do not operate the cushion valve in the fully closed or fully opened state.
Using it in the fully closed state will cause the cushion seal to be damaged. Using it in the fully opened state will cause the piston rod assembly or the cover to be damaged.

2. Operate within the specified cylinder speed.
Otherwise, cylinder and seal damage may occur.

⚠ Caution

1. Do not use the air cylinder as an air-hydro cylinder.
This will cause an oil leak.
2. Install a rod boot without twisting.
If the cylinder is installed with its bellows twisted, it could damage the bellows.

Disassembly/Replacement

⚠ Caution

1. Do not replace the bushings.
The bushings are press-fit. To replace them, they must be replaced together with the cover assembly.
2. To replace a seal, apply grease to the new seal before installing it.
If the cylinder is put into operation without applying grease to the seal, it could cause the seal to wear significantly, leading to premature air leakage.
3. Do not replace One-touch fittings.
Because pipe fittings are press-fit, they must be replaced together with the cover assembly.
4. Those with a bore of ø50 or more cannot be disassembled.
When disassembling cylinders with bore sizes of ø20 through ø40, grip the double flat part of either the head cover or the rod cover with a vise and loosen the other side with a wrench or a monkey wrench, etc., and then remove the cover. When re-tightening, tighten approximately 2 degrees more than the original position. (Cylinders with ø50 or larger bore sizes are tightened with a large tightening torque and cannot be disassembled. Please contact SMC when disassembly is required.)

Construction

With rubber bumper

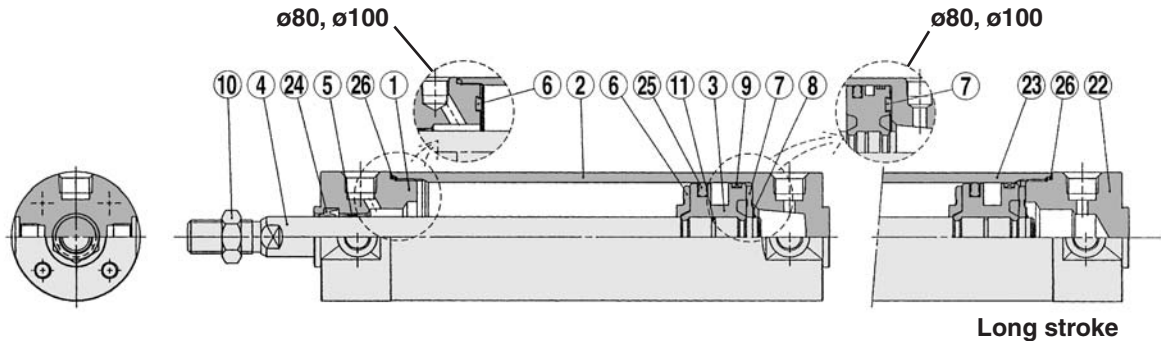

With air cushion

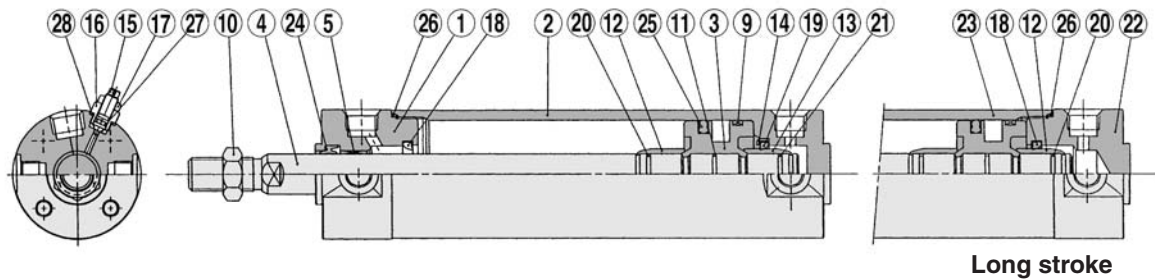

Component Parts

No.	Description	Material	Note
①	Rod cover	Aluminum alloy	Clear hard anodized
②	Tube cover	Aluminum alloy	Clear hard anodized
③	Piston	Aluminum alloy	Chromated
④	Piston rod	Carbon steel *	Hard chrome plated
⑤	Bushing	Oil-impregnated sintered alloy	ø40 and larger are lead-bronze casted
⑥	Bumper A	Urethane	
⑦	Bumper B	Urethane	ø40 or larger: The same as bumper A
⑧	Snap ring	Stainless steel	Except ø80 and ø100
⑨	Wear ring	Resin	
⑩	Rod end nut	Rolled steel	Nickel plated
⑪	Piston gasket	NBR	
⑫	Cushion ring A	Brass	
⑬	Cushion ring B	Brass	ø32 or larger: The same as A
⑭	Seal retainer	Rolled steel	Nickel plated/Except long stroke
⑮	Cushion valve	Rolled steel	Electroless nickel plated
⑯	Valve retainer	Rolled steel	Electroless nickel plated
⑰	Lock nut	Rolled steel	Nickel plated
⑱	Cushion seal A	Urethane	
⑲	Cushion seal B	Urethane	ø32 or larger: The same as A *
⑳	Cushion ring gasket A	NBR	
㉑	Cushion ring gasket B	NBR	ø32 or larger: The same as A
㉒	Head cover	Aluminum alloy	Clear hard anodized
㉓	Cylinder tube	Aluminum alloy	Hard anodized
㉔	Rod seal	NBR	
㉕	Piston seal	NBR	
㉖	Tube gasket	NBR	
㉗	Valve seal	NBR	
㉘	Valve retaining gasket	NBR	

Note) In the case of cylinders with auto switches, magnets are installed in the piston.

* The material is stainless steel on auto switch equipped styles ø20 and ø25.

Replacement Parts: Seal Kit for Rubber Bumper

Bore size (mm)	Kit no.	Contents
20	CG1N20-PS	Set of the nos. ㉔, ㉕, ㉖
25	CG1N25-PS	
32	CG1N32-PS	
40	CG1N40-PS	
50	CG1N50-PS	
63	CG1N63-PS	
100	CG1N100-PS	

Replacement Parts: Seal Kit for Air Cushion

Bore size (mm)	Kit no.	Contents
20	CG1A20-PS	Set of the nos. ㉔, ㉕, ㉖, ㉗, ㉘
25	CG1A25-PS	
32	CG1A32-PS	
40	CG1A40-PS	
50	CG1A50-PS	
63	CG1A63-PS	
100	CG1A100-PS	

Series NCG/CG1

Basic Style with Rubber Bumper: NCGBN/CG1BN

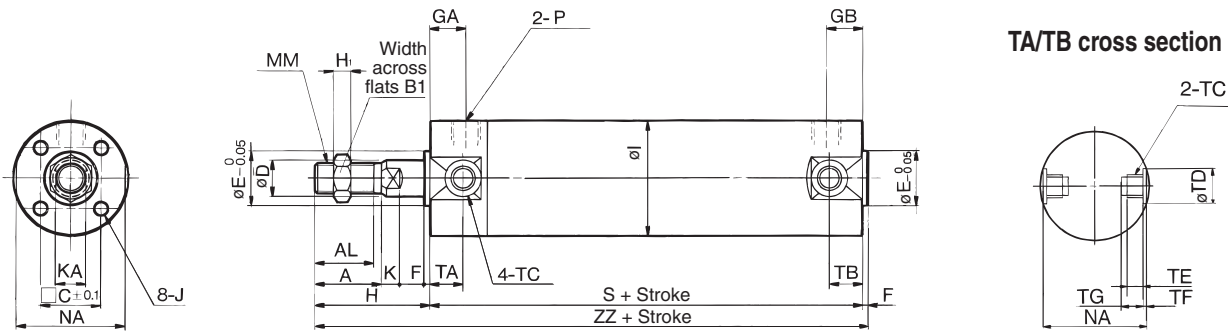

CG1 TA/TB Sectional View mm

Bore size (mm)	TC	TD _{H9}	TE	TF	TG
20	M5 x 0.8	8 ^{+0.08} ₀	4	0.5	5.5
25	M6 x 0.75	10 ^{+0.08} ₀	5	1	6.5
32	M8 x 1.0	12 ^{+0.08} ₀	5.5	1	7.5
40	M10 x 1.25	14 ^{+0.08} ₀	6	1.25	8.5
50	M12 x 1.25	16 ^{+0.08} ₀	7.5	2	10
63	M14 x 1.5	18 ^{+0.08} ₀	11.5	3	14.5
80	—	—	—	—	—
100	—	—	—	—	—

NCG TA/TB Sectional View Inch

Bore size (mm)	TC	TD _{H9}	TE	TF	TG
20	M5 x 0.8	0.315 ^{+0.003} ₀	0.16	0.02	0.22
25	M6 x 0.75	0.394 ^{+0.003} ₀	0.20	0.04	0.26
32	M8 x 1.0	0.472 ^{+0.003} ₀	0.22	0.04	0.30
40	M10 x 1.25	0.551 ^{+0.003} ₀	0.24	0.05	0.33
50	M12 x 1.25	0.630 ^{+0.003} ₀	0.30	0.08	0.39
63	M14 x 1.5	0.709 ^{+0.003} ₀	0.45	0.12	0.57

CG1 Basic style

Bore size (mm)	Standard stroke range (mm)	Long stroke range (mm)	A	AL	B ₁	C	D	E	F	GA	GB	H	H ₁	I	J	K	KA	MM	NA	P	S	TA	TB	ZZ
20	Up to 200	201 to 350	18	15.5	13	14	8	12	2	12	10(12)	35	5	26	M4 x 0.7 depth 7	5	6	M8 x 1.25	24	Rc 1/8	69(77)	11	11	106(114)
25	Up to 300	301 to 400	22	19.5	17	16.5	10	14	2	12	10(12)	40	6	31	M5 x 0.8 depth 7.5	5.5	8	M10 x 1.25	29	Rc 1/8	69(77)	11	11	111(119)
32	Up to 300	301 to 450	22	19.5	17	20	12	18	2	12	10(12)	40	6	38	M5 x 0.8 depth 8	5.5	10	M10 x 1.25	35.5	Rc 1/8	71(79)	11	10(11)	113(121)
40	Up to 300	301 to 800	30	27	19	26	16	25	2	13	10(13)	50	8	47	M6 x 1 depth 12	6	14	M14 x 1.5	44	Rc 1/8	78(87)	12	10(12)	130(139)
50	Up to 300	301 to 1200	35	32	27	32	20	30	2	14	12(14)	58	11	58	M8 x 1.25 depth 16	7	18	M18 x 1.5	55	Rc 1/4	90(102)	13	12(13)	150(162)
63	Up to 300	301 to 1200	35	32	27	38	20	32	2	14	12(14)	58	11	72	M10 x 1.5 depth 16	7	18	M18 x 1.5	69	Rc 1/4	90(102)	13	12(13)	150(162)
80	Up to 300	301 to 1400	40	37	32	50	25	40	3	20	16(20)	71	13	89	M10 x 1.5 depth 22	10	22	M22 x 1.5	80	Rc 3/8	108(122)	—	—	182(196)
100	Up to 300	301 to 1500	40	37	41	60	30	50	3	20	16(20)	71	16	110	M12 x 1.75 depth 22	10	26	M26 x 1.5	100	Rc 1/2	108(122)	—	—	182(196)

Note) (): Denotes the dimensions for long stroke.

* Trunnion mounting taps with width across flats NA are not attached for bore size ø80 and ø100.

NCG Basic style

Bore size (mm)	Standard stroke range (inch)	Long stroke range (inch)	A	AL	B ₁	C ^{+0.004}	D	E ^{+0.002}	F	GA	GB	H	H ₁	I
20	Up to 8	8.01 to 14	0.50	0.55	0.44	0.55	0.315	0.472	0.08	0.47	0.39 (0.47)	1.00	0.16	1.02
25	Up to 12	12.01 to 16	0.50	0.55	0.50	0.65	0.394	0.551	0.08	0.47	0.39 (0.47)	1.12	0.19	1.22
32	Up to 12	12.01 to 18	0.75	0.83	0.69	0.79	0.472	0.709	0.08	0.47	0.39 (0.47)	1.63	0.26	1.50
40	Up to 12	12.01 to 32	0.75	—	0.69	1.02	0.630	0.984	0.08	0.51	0.39 (0.51)	1.63	0.26	1.85
50	Up to 12	12.01 to 48	0.88	—	0.75	1.26	0.787	1.181	0.08	0.55	0.47 (0.55)	2.07	0.32	2.28
63	Up to 12	12.01 to 48	0.88	—	0.75	1.50	0.787	1.260	0.08	0.55	0.47 (0.55)	2.07	0.32	2.83

Bore size (mm)	J	K	KA	MM	NA	P (NPT)	S	TA	TB	ZZ
20	#8-32UNC depth 0.28	0.16	0.24	1/4-28UNF	0.94	1/8	2.72 (3.03)	0.43	0.43	3.80 (4.11)
25	#10-32UNF depth 0.30	0.20	0.31	5/16-24UNF	1.14	1/8	2.72 (3.03)	0.43	0.43	3.92 (4.23)
32	#10-32UNF depth 0.30	0.22	0.39	7/16-20UNF	1.40	1/8	2.80 (3.11)	0.43	0.39 (0.43)	4.51 (4.82)
40	1/4-28UNF depth 0.47	0.30	0.55	7/16-20UNF	1.73	1/8	3.07 (3.38)	0.47	0.39 (0.47)	4.78 (5.13)
50	5/16-24UNF depth 0.63	0.30	0.71	1/2-20UNF	2.17	1/4	3.54 (3.85)	0.51	0.47 (0.51)	5.69 (6.16)
63	3/8-24UNF depth 0.63	0.30	0.71	1/2-20UNF	2.72	1/4	3.54 (3.85)	0.51	0.47 (0.51)	5.69 (6.16)

Note) (): Denotes the dimensions for long stroke.

Refer to Model Selection Charts in Best Pneumatics for acceptable loading for long stroke cylinders.

Basic Style with Air Cushion: NCGBA/CG1BA

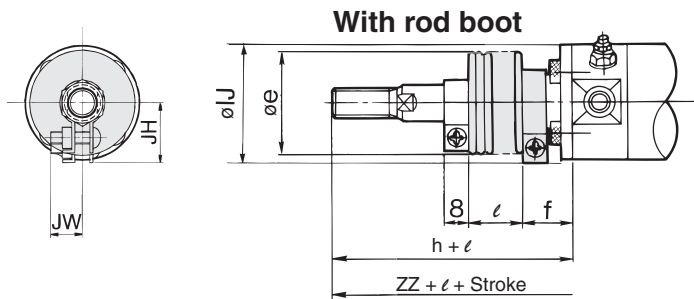
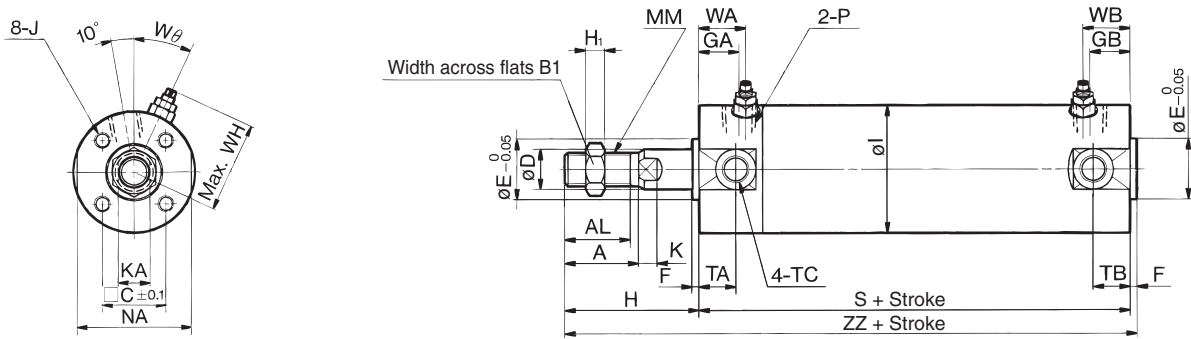

With Rod Boot

Bore size (mm)	e	f	h	IJ	JH	JW	l	ZZ
20	30	16	55	27	(14.5)	(11.5)	0.25 stroke	126(134)
25	30	17	62	32	(17.5)	(11.5)		133(141)
32	35	17	62	38	(19.5)	(11.5)		135(143)
40	35	17	70	48	(22.5)	(13)		150(159)
50	40	17	78	59	(25)	(13)		170(182)
63	40	18	78	72	(25)	(13)		170(182)
80	52	10	80	59	—	—		191(205)
100	62	7	80	71	—	—		191(205)

* The minimum stroke with rod boot is 20 mm.

CG1BA Basic style

Bore size (mm)	Standard stroke range (mm)	Long stroke range (mm)	A	AL	B ₁	C	D	E	F	GA	GB	H	H ₁	I	J	K	KA	MM	NA	P	S	TA	TB	TC*	ZZ	WA	WB	WH	Wθ
20	Up to 200	201 to 350	18	15.5	13	14	8	12	2	12	10(12)	35	5	26	M4 x 0.7 depth 7	5	6	M8 x 1.25	24	M5 x 0.8	69(77)	11	11	M5 x 0.8	106(114)	16	15(16)	23	30
25	Up to 300	301 to 400	22	19.5	17	16.5	10	14	2	12	10(12)	40	6	31	M5 x 0.8 depth 7.5	5.5	8	M10 x 1.25	29	M5 x 0.8	69(77)	11	11	M6 x 0.75	111(119)	16	15(16)	25	30
32	Up to 300	301 to 450	22	19.5	17	20	12	18	2	12	10(12)	40	6	38	M5 x 0.8 depth 8	5.5	10	M10 x 1.25	35.5	Rc 1/8	71(79)	11	10(11)	M8 x 1.0	113(121)	16	15(16)	28.5	25
40	Up to 300	301 to 800	30	27	19	26	16	25	2	13	10(13)	50	8	47	M6 x 1 depth 12	6	14	M14 x 1.5	44	Rc 1/8	78(87)	12	10(12)	M10 x 1.25	130(139)	16	15(16)	33	20
50	Up to 300	301 to 1200	35	32	27	32	20	30	2	14	12(14)	58	11	58	M8 x 1.25 depth 16	7	18	M18 x 1.5	55	Rc 1/4	90(102)	13	12(13)	M12 x 1.25	150(162)	18	17(18)	40.5	20
63	Up to 300	301 to 1200	35	32	27	38	20	32	2	14	12(14)	58	11	72	M10 x 1.5 depth 16	7	18	M18 x 1.5	69	Rc 1/4	90(102)	13	12(13)	M14 x 1.5	150(162)	18	17(18)	47.5	20
80	Up to 300	301 to 1400	40	37	32	50	25	40	3	20	16(20)	71	13	89	M10 x 1.5 depth 22	10	22	M22 x 1.5	80	Rc 3/8	108(122)	—	—	—	182(196)	22	22	60.5	20
100	Up to 300	301 to 1500	40	37	41	60	30	50	3	20	16(20)	71	16	110	M12 x 1.75 depth 22	10	26	M26 x 1.5	100	Rc 1/2	108(122)	—	—	—	182(196)	22	22	71	20

Note) (): Denotes the dimensions for long stroke.

* Trunnion mounting taps with width across flats NA are not attached for bore size ø80 and ø100.

* For mounting brackets, refer to Best Pneumatics.

NCGBA Basic style

Bore size (mm)	Standard stroke range (inch)	Long stroke range (inch)	A	AL	B ₁	C ±0.004	D	E ⁺⁰ / _{-0.002}	F	GA	GB	H	H ₁	I	J
20	Up to 8	8.01 to 14	0.50	0.55	0.44	0.55	0.315	0.472	0.08	0.47	0.39 (0.47)	1.00	0.16	1.02	#8-32UNC depth 0.28
25	Up to 12	12.01 to 16	0.50	0.55	0.50	0.65	0.394	0.551	0.08	0.47	0.39 (0.47)	1.12	0.19	1.22	#10-32UNF depth 0.30
32	Up to 12	12.01 to 18	0.75	0.83	0.69	0.79	0.472	0.709	0.08	0.47	0.39 (0.47)	1.63	0.26	1.50	#10-32UNF depth 0.30
40	Up to 12	12.01 to 32	0.75	—	0.69	1.02	0.630	0.984	0.08	0.51	0.39 (0.51)	1.63	0.26	1.85	1/4-28UNF depth 0.47
50	Up to 12	12.01 to 48	0.88	—	0.75	1.26	0.787	1.181	0.08	0.55	0.47 (0.55)	2.07	0.32	2.28	5/16-24UNF depth 0.63
63	Up to 12	12.01 to 48	0.88	—	0.75	1.50	0.787	1.260	0.08	0.55	0.47 (0.55)	2.07	0.32	2.83	3/8-24UNF depth 0.63

Bore size (mm)	K	KA	MM	NA	P (NPT)	S	TA	TB	TC	ZZ	WA	WB	WH	Wθ
20	0.16	0.24	1/4-28UNF	0.94	#10-32UNF	2.72 (3.03)	0.43	0.43	M5 x 0.8	3.80 (4.11)	0.63	0.59 (0.63)	0.91	30
25	0.20	0.31	5/16-24UNF	1.14	#10-32UNF	2.72 (3.03)	0.43	0.43	M6 x 0.75	3.92 (4.23)	0.63	0.59 (0.63)	0.98	30
32	0.22	0.39	7/16-20UNF	1.40	1/8	2.80 (3.11)	0.43	0.39 (0.43)	M8 x 1.0	4.51 (4.82)	0.63	0.59 (0.63)	1.12	25
40	0.30	0.55	7/16-20UNF	1.73	1/8	3.07 (3.38)	0.47	0.39 (0.47)	M10 x 1.25	4.78 (5.13)	0.63	0.59 (0.63)	1.30	20
50	0.30	0.71	1/2-20UNF	2.17	1/4	3.54 (3.85)	0.51	0.47 (0.51)	M12 x 1.25	5.69 (6.16)	0.71	0.67 (0.71)	1.59	20
63	0.30	0.71	1/2-20UNF	2.72	1/4	3.54 (3.85)	0.51	0.47 (0.51)	M14 x 1.5	5.69 (6.16)	0.71	0.67 (0.71)	1.87	20

Note) (): Denotes the dimensions for long stroke.

Refer to Model Selection Charts in Best Pneumatics for acceptable loading for long stroke cylinders.

Series NCG/CG1

Basic Style: NCGBN/CG1BN

Basic style with rod boot

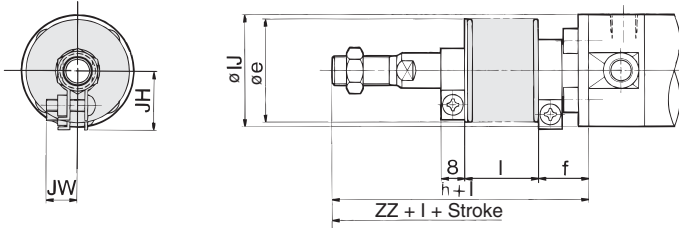

Built-in One-touch fittings

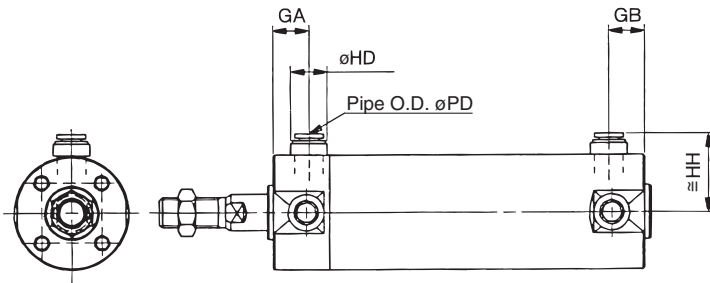

Other dimensions are the same as standard.

Air-hydro

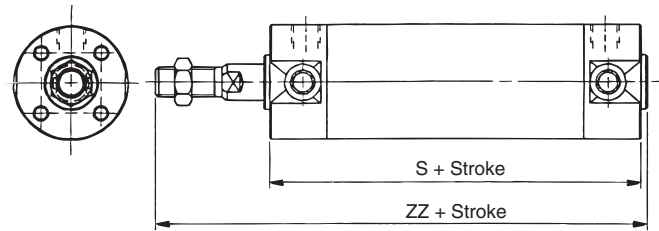

Other dimensions are the same as the long stroke standard.

CG1 With Rod Boot

Bore size (mm)	e	f	h	IJ	JH	JW	I	ZZ
20	30	16	55	27	(14.5)	(11.5)	0.25 stroke	126(134)
25	30	17	62	32	(17.5)	(11.5)		133(141)
32	35	17	62	38	(19.5)	(11.5)		135(143)
40	35	17	70	48	(22.5)	(13)		150(159)
50	40	17	78	59	(25)	(13)		170(182)
63	40	18	78	72	(25)	(13)		170(182)
80	52	10	80	59	—	—		191(205)
100	62	7	80	71	—	—		191(205)

* The minimum stroke with rod boot is 20 mm.

CG1 Built-in One-touch Fittings

Bore size (mm)	GA	GB	HD	HH	PD
20	12	12	13	24.2	6
25	12	10(12)	13	26.7	6
32	12	10(12)	13	30.2	6
40	12	10(12)	16	34.6	8
50	13	13	20	40.6	10
63	13	13	20	47.1	10

Note) (): Denotes the dimensions for long stroke.

CG1 Air-hydro

Bore size (mm)	S	ZZ
20	77	114
25	77	119
32	79	121
40	87	139
50	102	162
63	102	162

With Mounting Bracket $\phi 20$ to $\phi 63$

Axial foot style: CG1LN

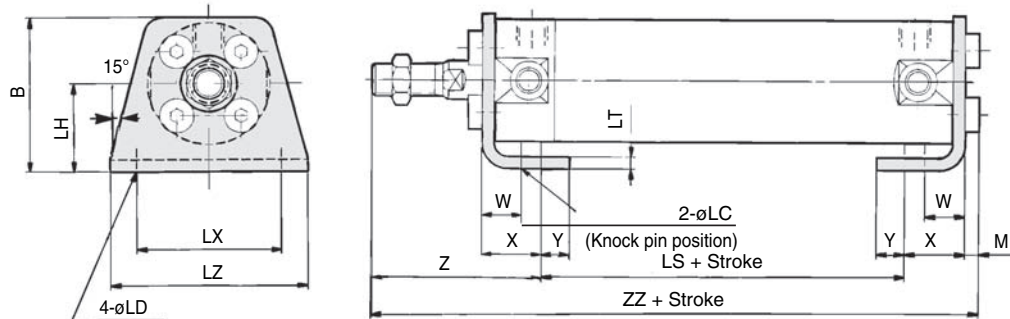

CG1 Axial Foot Style

mm

Bore size (mm)	B	LC	LD	LH	LS	LT	LX	LZ	M	W	X	Y	Z		ZZ	
													Without rod boot	With rod boot	Without rod boot	With rod boot
20	34	4	6	20	45 (53)	3	32	44	3	10	15	7	47	67 + ℓ	110 (118)	130 (138) + ℓ
25	38.5	4	6	22	45 (53)	3	36	49	3.5	10	15	7	52	74 + ℓ	115.5 (123.5)	137.5 (145.5) + ℓ
32	45	4	7	25	45 (53)	3	44	58	3.5	10	16	8	53	75 + ℓ	117.5 (125.5)	139.5 (147.5) + ℓ
40	54.5	4	7	30	51 (60)	3	54	71	4	10	16.5	8.5	63.5	83.5 + ℓ	135 (144)	155 (164) + ℓ
50	70.5	5	10	40	55 (67)	4.5	66	86	5	17.5	22	11	75.5	95.5 + ℓ	157.5 (169.5)	177.5 (189.5) + ℓ
63	82.5	5	12	45	55 (67)	4.5	82	106	5	17.5	22	13	75.5	95.5 + ℓ	157.5 (169.5)	177.5 (189.5) + ℓ
80	101	6	11	55	60 (74)	4.5	100	125	5	20	28.5	14	95	104 + ℓ	188.5 (202.5)	197.5 (211.5) + ℓ
100	121	6	14	65	60 (74)	6	120	150	7	20	30	16	95	104 + ℓ	192 (206)	201 (215) + ℓ

Note) (): Denotes the dimensions for long stroke.
* Other dimensions are the same as basic style.

Axial foot style: NCGL

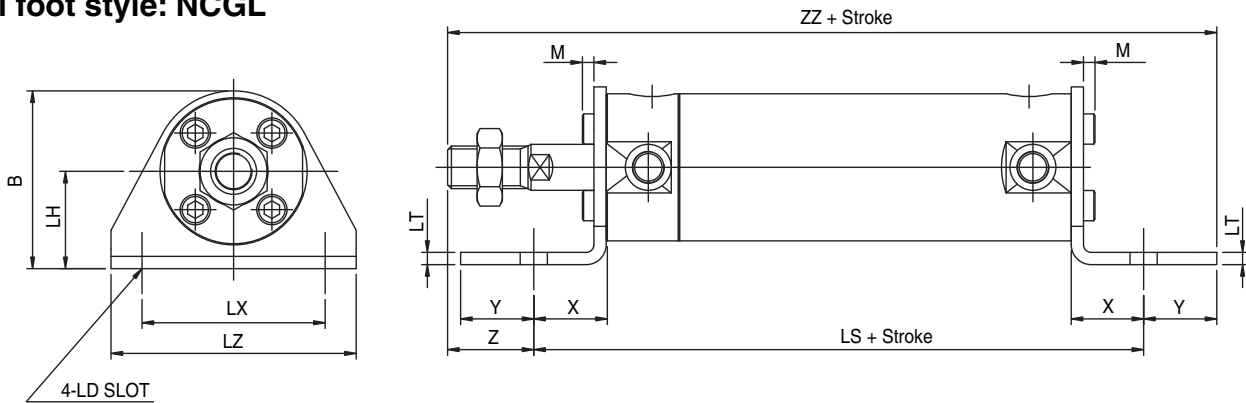

NCG Axial Foot Style

Inch

Bore size (mm)	Stroke range (inch)	B	LD	LH	LS	LT	LX	LZ	M	W	X	Y	Z	ZZ
20	Up to 14	1.44	0.27	0.81	3.82 (4.13)	0.12	1.50	1.88	0.16	1.02	0.56	0.44	0.44	4.70 (5.01)
25	Up to 16	1.52	0.27	0.81	3.82 (4.13)	0.12	1.50	1.88	0.19	1.22	0.56	0.44	0.56	4.82 (5.13)
32	Up to 18	1.83	0.28	1.00	4.28 (4.59)	0.12	1.88	2.50	0.26	1.50	0.75	0.75	0.88	5.91 (6.22)
40	Up to 32	2.02	0.28	1.00	4.50 (4.86)	0.12	1.88	2.50	0.26	1.85	0.72	0.78	0.91	6.19 (6.55)
50	Up to 48	2.84	0.34	1.50	5.53 (6.01)	0.25	2.25	3.12	0.32	2.28	1.00	0.62	1.07	7.22 (7.70)
63	Up to 48	3.29	0.34	1.75	5.53 (6.01)	0.25	2.88	3.75	0.32	2.83	1.00	0.62	1.07	7.22 (7.70)

Note) (): Denotes the dimension for long stroke
* Other dimensions are the same as basic style

Series NCG/CG1

With Mounting Bracket

Rod side trunnion style: NCGUN/CG1UN

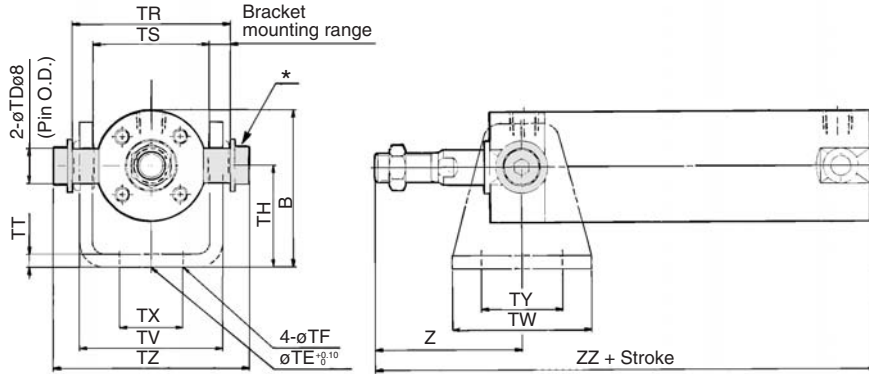

Head side trunnion style: NCGTN/CG1TN

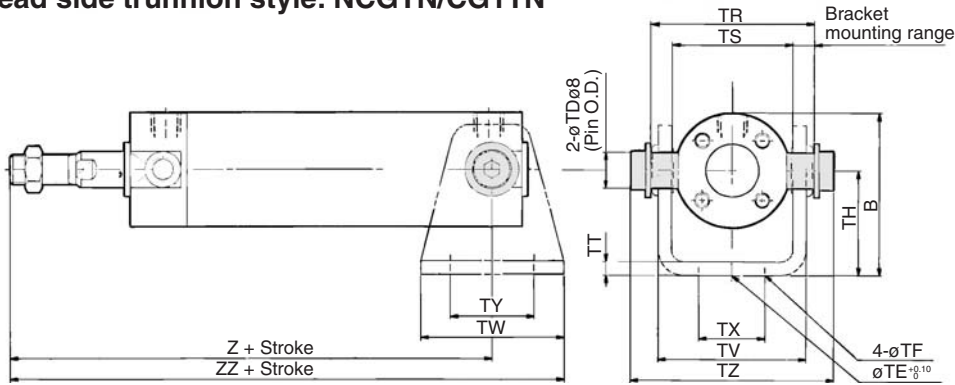

CG1 Trunnion Style

Bore size (mm)	Stroke range		B	TDe8	TE	TF	TH	TR	TS	TT	TV	TW	TX	TY	TZ	mm					
																Rod side		Head side			
	Without rod boot	With rod boot														Z	Z	ZZ			
20	Up to 200	Up to 200	38	8 ^{-0.025} _{-0.047}	10	5.5	25	39	28	3.2	(35.8)	42	16	28	47.6	46	66 + ℓ	93	113 + ℓ	114	134 + ℓ
25	Up to 300	Up to 300	45.5	10 ^{-0.025} _{-0.047}	10	5.5	30	43	33	3.2	(39.8)	48	20	28	53	51	73 + ℓ	98	120 + ℓ	119	141 + ℓ
32	Up to 300	Up to 300	54	12 ^{-0.032} _{-0.059}	10	6.6	35	54.5	40	4.5	(49.4)	48	22	28	67.7	51	73 + ℓ	101	123 + ℓ	125	147 + ℓ
40	Up to 500	Up to 500	63.5	14 ^{-0.032} _{-0.059}	10	6.6	40	65.5	49	4.5	(58.4)	56	30	30	78.7	62	82 + ℓ	118 (125)	138 (145) + ℓ	146 (153)	166 (173) + ℓ
50	Up to 600	Up to 600	79	16 ^{-0.032} _{-0.059}	20	9	50	80	60	6	(72.4)	64	36	36	98.6	71	91 + ℓ	136 (147)	156 (167) + ℓ	168 (179)	188 (199) + ℓ
63	Up to 600	Up to 600	96	18 ^{-0.032} _{-0.059}	20	11	60	98	74	8	(90.4)	74	46	46	119.2	71	91 + ℓ	136 (147)	156 (167) + ℓ	173 (184)	193 (204) + ℓ

* Consists of pin, flat washer and hexagon socket head cap bolt.

Note) (): Denotes the dimensions for long stroke. Refer to Best Pneumatics for pivot bracket.

* Other dimensions are the same as basic style.

NCG Trunnion Style

Bore size (mm)	Stroke range		B	TDe8	TE	TF	TH	TR	TS	TT	TV	TW	TX	TY	TZ	Inch			
																Rod side		Head side	
	Without rod boot	With rod boot														Z	Z	ZZ	ZZ
20	Up to 8	Up to 8	1.50	0.315 ^{-0.0009} _{-0.0019}	0.39	0.22	0.98	1.54	1.10	0.13	(1.41)	1.65	0.63	1.10	1.87	1.43	3.29	3.80	4.10
25	Up to 12	Up to 12	1.79	0.394 ^{-0.0009} _{-0.0019}	0.39	0.22	1.18	1.69	1.30	0.13	(1.57)	1.65	0.79	1.10	2.09	1.55	3.41	3.92	4.22
32	Up to 12	Up to 12	2.13	0.472 ^{-0.0013} _{-0.0023}	0.39	0.26	1.38	2.15	1.57	0.18	(1.94)	1.89	0.87	1.10	2.67	2.06	4.04	4.51	4.96
40	Up to 20	Up to 20	2.50	0.551 ^{-0.0013} _{-0.0023}	0.39	0.26	1.57	2.58	1.93	0.18	(2.30)	2.20	1.18	1.18	3.10	2.10	4.31 (4.66)	4.78 (5.13)	5.39 (5.74)
50	Up to 24	Up to 24	3.11	0.630 ^{-0.0013} _{-0.0023}	0.79	0.35	1.97	3.15	2.36	0.24	(2.85)	2.52	1.42	1.42	3.88	2.58	5.14 (5.61)	5.69 (6.16)	6.39 (6.86)
63	Up to 24	Up to 24	3.78	0.709 ^{-0.0013} _{-0.0023}	0.79	0.43	2.36	3.86	2.91	0.31	(3.56)	2.91	1.81	1.81	4.69	2.58	5.14 (5.61)	5.69 (6.16)	6.59 (7.06)

Note) (): Denotes the dimensions for long stroke. Refer to Best Pneumatics for pivot bracket.

* Other dimensions are the same as basic style.

With Mounting Bracket

Rod side flange style: NCGFN/CG1FN

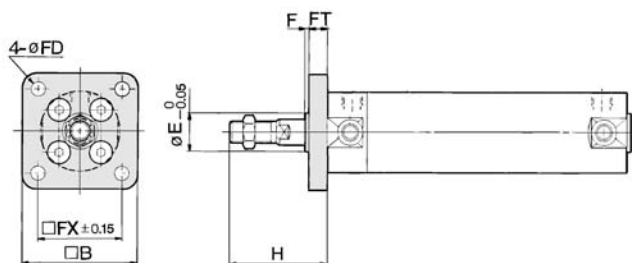

**Head side flange style: NCGGN/CG1GN
CG1GN**

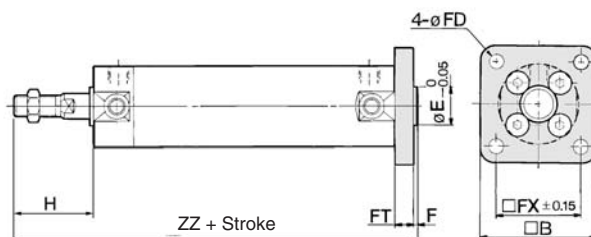

CG1 Flange Style

Bore size (mm)	Stroke range		B	E	F	FX	FD	FT	H	Head side flange ZZ	
	Rod side	Head side								Without rod boot	With rod boot
	20	Up to 350								Up to 200	40
25	Up to 400	Up to 300	44	14	2	32	5.5	7	40	118	140 + ℓ
32	Up to 450	Up to 300	53	18	2	38	6.6	7	40	120	142 + ℓ
40	Up to 800	Up to 500	61	25	2	46	6.6	8	50	138 (147)	158 (167) + ℓ
50	Up to 1200	Up to 600	76	30	2	58	9	9	58	159 (171)	179 (191) + ℓ
63	Up to 1200	Up to 600	92	32	2	70	11	9	58	159 (171)	179 (191) + ℓ
80	Up to 1400	Up to 750	104	40	3	82	11	11	71	193 (207)	202 (216) + ℓ
100	Up to 1500	Up to 750	128	50	3	100	14	14	71	196 (210)	202 (219) + ℓ

Note) (): Denotes the dimensions for long stroke.
End boss is machined on the flange for øE.
* Other dimensions are the same as basic style.

NCG Flange Style

Bore size (mm)	Stroke range		B	E	F	FX	FD	FT	H	Head side flange ZZ
	Rod side	Head side								Inch
	20	Up to 14								Up to 8
25	Up to 16	Up to 12	1.73	0.551 ⁺⁰ _{-0.0011}	0.08	1.26	0.22	0.28	1.12	4.28
32	Up to 18	Up to 12	2.09	0.709 ⁺⁰ _{-0.0011}	0.08	1.50	0.28	0.28	1.63	4.87
40	Up to 32	Up to 20	2.40	0.984 ⁺⁰ _{-0.0013}	0.08	1.81	0.28	0.31	1.63	5.17 (5.52)
50	Up to 48	Up to 24	3.00	1.181 ⁺⁰ _{-0.0013}	0.08	2.28	0.35	0.35	2.07	6.12 (6.59)
63	Up to 48	Up to 24	3.62	1.260 ⁺⁰ _{-0.0015}	0.08	2.76	0.43	0.35	2.07	6.12 (6.59)

Note) (): Denotes the dimensions for long stroke.
* Other dimensions are the same as basic style.

Series NCG/CG1

With Mounting Bracket

Clevis style: NCGDN/CG1DN

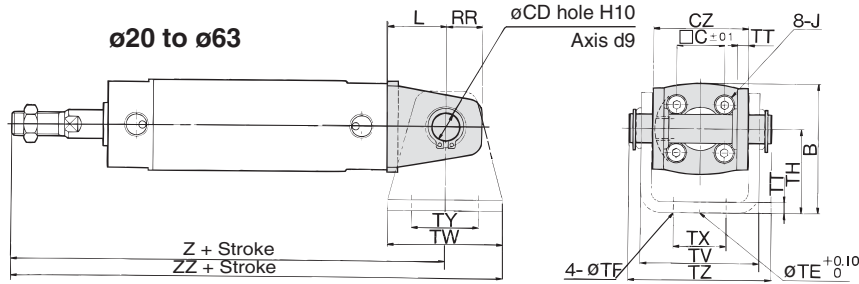

(The above shows the case port location is changed by 90.)

Clevis style: CG1DN

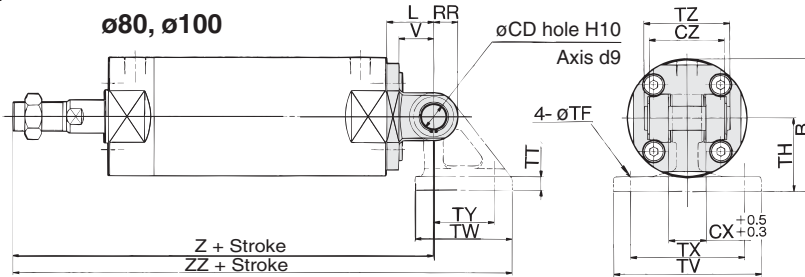

* Clevis pin and snap ring are attached for the clevis style.

CG1 Clevis Style

Bore size (mm)	Stroke range (mm)	B	CD	CX	CZ	J	L	RR	V	TE	TF	TH	TT	TV	TW	TX	TY	TZ	Z	ZZ	With rod boot		Applicable pin part no.
																					Z	ZZ	
20	Up to 200	38	8	—	29	M4 x 0.7 depth 7	14	11	—	10	5.5	25	3.2	35.8	42	16	28	43.4	118	139	138 + l	159 + l	CD-G02
25	Up to 300	45.5	10	—	33	M5 x 0.8 depth 7.5	16	13	—	10	5.5	30	3.2	39.8	42	20	28	48	125	146	147 + l	168 + l	CD-G25
32	Up to 300	54	12	—	40	M5 x 0.8 depth 8	20	15	—	10	6.6	35	4.5	49.4	48	22	28	59.4	131	155	153 + l	177 + l	CD-G03
40	Up to 500	63.5	14	—	49	M6 x 1 depth 12	22	18	—	10	6.6	40	4.5	58.4	56	30	30	71.4	150 (159)	178 (187)	170 + l (179 + l)	198 + l (207 + l)	CD-G04
50	Up to 600	79	16	—	60	M8 x 1.25 depth 16	25	20	—	20	9	50	6	72.4	64	36	36	86	173 (185)	205 (217)	193 + l (205 + l)	225 + l (237 + l)	CD-G05
63	Up to 600	96	18	—	74	M10 x 1.5 depth 16	30	22	—	20	11	60	8	90.4	74	46	46	105.4	178 (190)	215 (227)	198 + l (210 + l)	235 + l (247 + l)	CD-G06
80	Up to 750	99.5	18	28	56	M10 x 1.5 depth 22	35	18	26	—	11	55	11	110	72	85	45	64	214 (228)	272.5 (286.5)	223 + l (237 + l)	281.5 + l (295.5 + l)	IY-G08
100	Up to 750	120	22	32	64	M12 x 1.75 depth 22	43	22	32	—	13.5	65	12	130	93	100	60	72	222 (236)	298.5 (312.5)	231 + l (245 + l)	307.5 + l (321.5 + l)	IY-G10

mm

Note) (): Denotes the dimensions for long stroke.

* Refer to Best Pneumatics for pivot bracket.

* Other dimensions are the same as basic style.

NCG Double Clevis Style

Bore size (mm)	Stroke range (mm)	B	CD	CX	CZ	J	L	RR	V	TE	TF	TH	TT	TV	TW	TX	TY	TZ	Z	ZZ	inch	
																					Z	ZZ
20	Up to 8	1.50	0.31	—	1.14	#8-32UNC depth 0.28	0.55	0.43	—	0.39	0.22	0.98	0.13	1.41	1.65	0.63	1.10	1.71	4.35	5.08		
25	Up to 12	1.79	0.39	—	1.30	#10-32UNF depth 0.30	0.63	0.51	—	0.39	0.22	1.18	0.13	1.57	1.65	0.79	1.10	1.89	4.55	5.28		
32	Up to 12	2.13	0.47	—	1.57	#10-32UNF depth 0.30	0.79	0.59	—	0.39	0.26	1.38	0.18	1.94	1.89	0.87	1.10	2.34	5.30	6.14		
40	Up to 20	2.50	0.55	—	1.93	1/4-28UNF depth 0.47	0.87	0.71	—	0.39	0.26	1.57	0.18	2.30	2.20	1.18	1.18	2.81	5.65 (6.00)	6.66 (7.01)		
50	Up to 24	3.11	0.63	—	2.36	5/16-24UNF depth 0.63	0.98	0.79	—	0.79	0.35	1.97	0.24	2.85	2.52	1.42	1.42	3.39	6.67 (7.14)	7.84 (8.31)		
63	Up to 24	3.78	0.71	—	2.91	3/8-24UNF depth 0.63	1.18	0.87	—	0.79	0.43	2.36	0.31	3.56	2.91	1.81	1.81	4.15	6.87 (7.34)	8.26 (8.73)		

Note) (): Denotes the dimensions for long stroke.

* Other dimensions are the same as basic style.

Basic Style with Single Clevis: NCGC

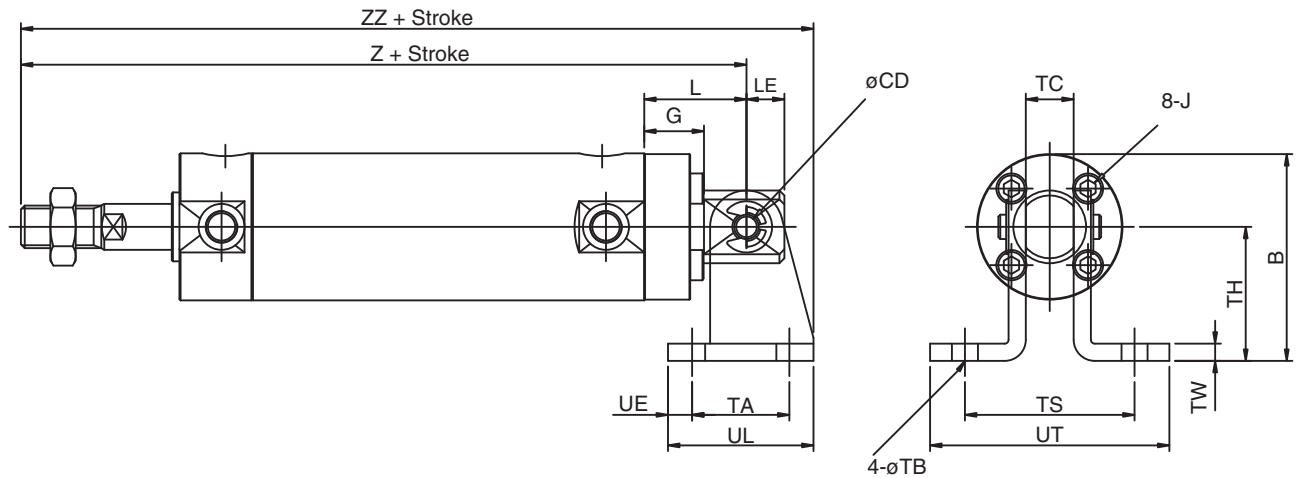

Inch

Bore size (mm)	Standard stroke range	B	CD	G	J	L	LE	TA	TB	TC	TH	TS	TW	UE	UL	UT	Z	ZZ
20	Up to 8	1.39	0.250	0.31	#8-32UNC depth 0.28	0.70	0.28	0.75	0.27	0.38	0.88	1.25	0.12	0.18	1.10	2.00	4.50	5.08
25	Up to 12	1.49	0.250	0.33	#10-32UNF depth 0.30	0.68	0.28	0.75	0.27	0.38	0.88	1.25	0.12	0.18	1.10	2.00	4.60	5.28
32	Up to 12	1.63	0.250	0.61	#10-32UNF depth 0.30	1.07	0.39	0.75	0.27	0.50	0.88	1.38	0.12	0.18	1.10	2.12	5.58	6.14
40	Up to 20	2.31	0.375	0.39	1/4-28UNF depth 0.47	0.88	0.38	1.00	0.27	0.62	1.38	1.86	0.18	0.25	1.50	2.62	5.66 (6.01)	6.66 (7.01)
50	Up to 24	2.52	0.375	0.47	5/16-24UNF depth 0.63	0.91	0.44	1.00	0.26	0.75	1.38	2.12	0.25	0.25	1.50	3.00	6.60 (7.07)	7.84 (8.31)
63	Up to 24	3.17	0.375	0.47	3/8-24UNF depth 0.63	0.91	0.44	1.00	0.26	0.75	1.75	2.12	0.25	0.25	1.50	3.00	6.60 (7.07)	8.26 (8.73)

Note) (): Denotes the dimensions for long stroke.

* Other dimensions are the same as basic style.

Series NCG/CG1

Basic Style with Front Nose: NCGN

20mm and 25mm Bores

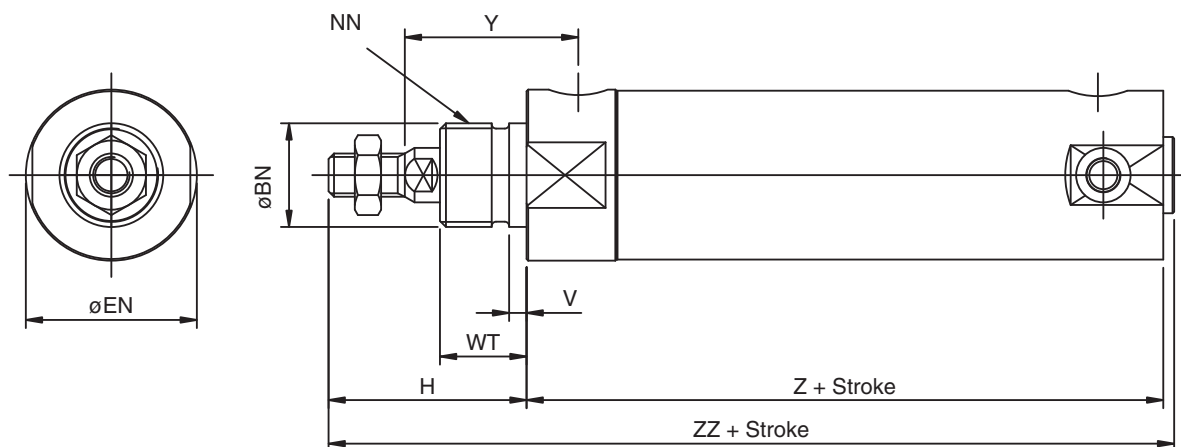

32mm Through 63mm Bores

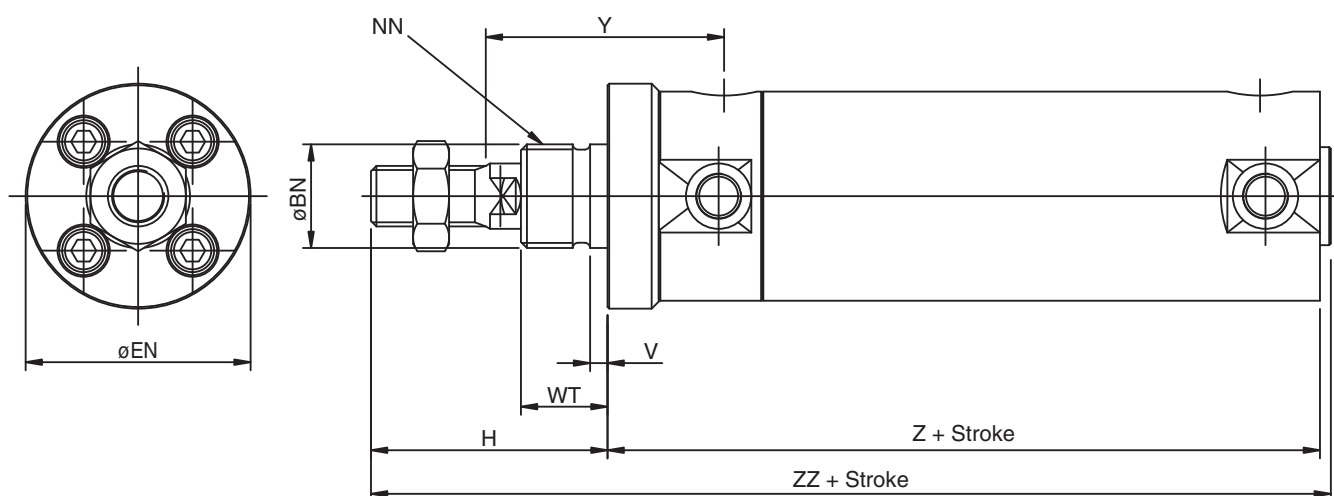

NCG Front Nose style

Bore size (mm)	Standard stroke range (inch)	Inch								
		BN	EN	H	NN	V	WT	Y	Z	ZZ
20	Up to 8	0.749 ^{+0.0002} _{-0.003}	1.12	1.43	3/4-16UNF	0.12	0.63	1.25	2.60	4.11
25	Up to 12	0.749 ^{+0.0002} _{-0.003}	1.24	1.43	3/4-16UNF	0.12	0.63	1.25	2.60	4.11
32	Up to 12	0.749 ^{+0.0002} _{-0.003}	1.63	1.71	3/4-16UNF	0.12	0.63	1.75	3.15	4.94
40	Up to 12	1.058 ^{+0.0002} _{-0.003}	2.00	2.00	1-14UNF	0.19	0.88	2.32	3.62	5.70
50	Up to 12	1.374 ⁺⁰ _{-0.0039}	2.38	2.07	1-1/4-12UNF	0.12	0.81	2.33	4.12	6.27
63	Up to 12	1.500 ⁺⁰ _{-0.0039}	2.87	2.07	1-3/8-12UNF	0.12	0.81	2.40	4.19	6.34

Note) Other dimensions are the same as basic style.

Auto Switch Mounting Position (Detection at stroke end) and Its Mounting Height

D-C7, D-C8
ø20 to ø63

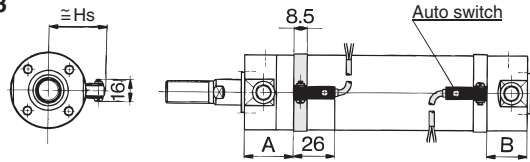

D-G5, D-K5, D-G5□W, D-G5BAL
D-K59W, D-G59F, D-G5NTL

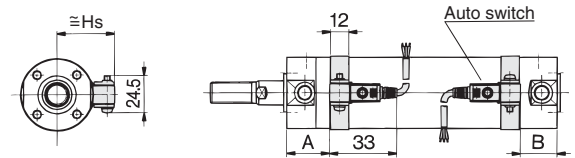

D-M9, D-M9W,
D-M9A
ø20 to ø63

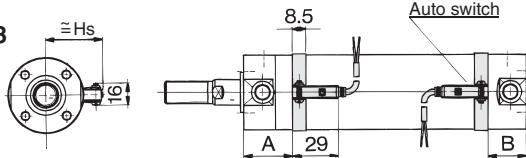

D-C73C, D-C80C
ø20 to ø63

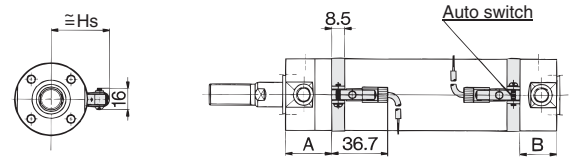

D-B5, D-B6, D-B59W
ø20 to ø100

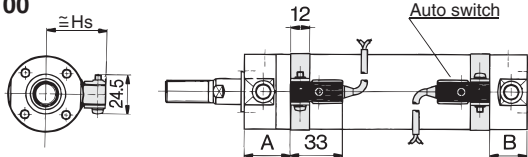

Proper Auto Switch Mounting Position

Auto switch model	Bore size (mm)									
	D-C7/C8 D-C73C D-C80C		D-B5/B6		D-B59W		D-M9 D-M9W D-M9A		D-G5□W D-K59W D-G59F D-G5 D-K5 D-G5NTL D-G5BAL	
	A	B	A	B	A	B	A	B	A	B
20	30	20.5 (28.5)	24	15.5 (22.5)	27	17.5 (25.5)	29	19.5 (27.5)	25.5	16 (24)
25	30	20.5 (28.5)	24	15.5 (22.5)	27	17.5 (25.5)	29	19.5 (27.5)	25.5	16 (24)
32	31	21.5 (29.5)	25	15.5 (23.5)	28	18.5 (26.5)	30	20.5 (28.5)	26.5	17 (25)
40	35.5	23.5 (32.5)	29.5	19 (26.5)	32.5	20.5 (29.5)	34.5	22.5 (31.5)	31	19 (28)
50	43	28.5 (40.5)	37	22.5 (34.5)	40	25.5 (37.5)	42	27.5 (39.5)	38.5	24 (36)
63	43	28.5 (40.5)	37	22.5 (34.5)	40	25.5 (37.5)	42	27.5 (39.5)	38.5	24 (36)
80	—	—	46.5	30.5 (44.5)	49.5	33.5 (47.5)	—	—	48	32 (46)
100	—	—	46.5	30.5 (44.5)	49.5	33.5 (47.5)	—	—	48	32 (46)

(): Denotes the dimensions for long stroke, bore size ø20 to ø100, double rod.

Auto Switch Mounting Height

D-C7/C8 D-M9 D-M9W D-M9A	D-C73C D-C80C	D-B5/B6 D-B59W D-G5/K5 D-G5□W D-K59W	D-G5NTL D-G59F D-G5BAL
HS	HS	HS	
24.5	27	27.5	
27	29.5	30	
30.5	33	33.5	
35	37.5	38	
40.5	43	43.5	
47.5	50	50.5	
—	—	59	
—	—	69.5	

Operating Range







Auto switch model	Bore size (mm)							
	20	25	32	40	50	63	80	100
D-C7□/C80 D-C73C/C80C	8	10	9	10	10	11	—	—
D-B5□/B64	8	10	9	10	10	11	11	11
D-B59W	13	13	14	14	14	17	16	18
D-M9, M9W D-M9A	4	4	4.5	5	6	6.5	—	—
D-H7C	7	8.5	9	10	9.5	10.5	—	—
D-G5□/G5□W/G59F D-G5BAL/K59/K59W	—	—	—	—	—	—	6.5	7
D-G5NTL	4	4	4.5	5	6	6.5	6.5	7
D-G5NBL	35	40	40	45	45	45	45	50

* Since this is a guideline including hysteresis, not meant to be guaranteed. (Assuming approximately 30% dispersion) There may be the case it will vary substantially depending on an ambient environment.

Series NCG/CG1

Auto Switch Mounting Bracket, Mounting by Stroke

st: Stroke (mm)

Mounting bracket	Basic style, Foot style, Flange style, Clevis style			Trunnion style *		
	1 (Rod cover side)	2 (Different sides)	2 (Mounted on the same side)	1	2 (Different sides)	2 (Mounted on the same side)
Switch mounting surface	Port surface 	Port surface 	Port surface 			
Switch type						
D-C7/C8	10 st or more	15 to 49 st	50 st or more	10 st or more	15 to 49 st	50 st or more
D-M9□/M9□W D-M9□A	10 st or more	15 to 59 st	60 st or more	10 st or more	15 to 59 st	60 st or more
D-C73C/C80C/H7C	10 st or more	15 to 64 st	65 st or more	10 st or more	15 to 64 st	65 st or more
D-B5/B6/G5/K5 D-G5□W/K59W/G5BAL D-G59F/G5NTL	10 st or more	15 to 74 st	75 st or more	10 st or more	15 to 74 st	75 st or more
D-B59W	15 st or more	20 to 74 st	75 st or more	15 st or more	20 to 74 st	75 st or more

* Trunnion style is not available for bore sizes ø80 and ø100.

Other than the applicable auto switches listed in “How to Order”, the following auto switches can be mounted. For detailed specifications, refer to Best Pneumatics.

Type	Model	Electrical entry	Features	Applicable bore size (mm)
Reed switch	D-C80	Grommet	Without indicator light	20 to 63
	D-C80C	Connector		
	D-B53	Grommet	—	20 to 100
	D-B64	Grommet	Without indicator light	

* Timer equipped type, solid state auto switch (D-G5NTL) is also available.

* Wide range detection type, solid state auto switch (D-G5NBL) is also available.

* With pre-wire connector is available for D-G5NTL and D-G5NBL.

Series NCG/CG1

Accessory Bracket Dimensions

CG1 Single Knuckle Joint

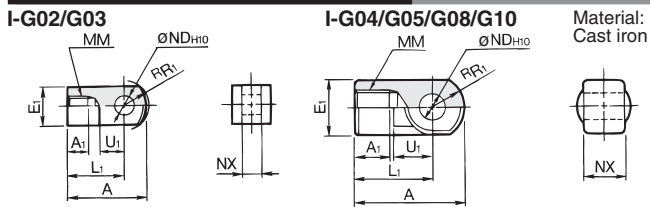

Material: Rolled steel mm

Part no.	Applicable bore (mm)	A	A ₁	E ₁	L ₁	MM	R ₁	U ₁	ND _{H10}	NX
I-G02	20	34	8.5	16	25	M8 x 1.25	10.3	11.5	8 ^{+0.058} ₀	8 ^{-0.2} _{-0.4}
I-G03	25, 32	41	10.5	20	30	M10 x 1.25	12.8	14	10 ^{+0.058} ₀	10 ^{-0.2} _{-0.4}
I-G04	40	42	14	Ø22	30	M14 x 1.5	12	14	10 ^{+0.058} ₀	18 ^{-0.3} _{-0.5}
I-G05	50, 63	56	18	Ø28	40	M18 x 1.5	16	20	14 ^{+0.070} ₀	22 ^{-0.3} _{-0.5}
I-G08	80	71	21	Ø38	50	M22 x 1.5	21	27	18 ^{+0.070} ₀	28 ^{-0.3} _{-0.5}
I-G10	100	79	21	Ø44	55	M26 x 1.5	24	31	22 ^{+0.084} ₀	32 ^{-0.3} _{-0.5}

NCG Single Knuckle Joint

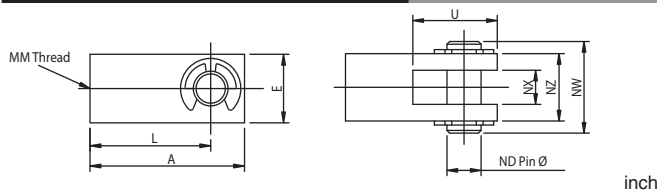

Material: Rolled steel inch

Part no.	Applicable bore (mm)	A	E	L	MM	ND	NX	NW	NZ	U
NY-075	20	1.19	0.51	0.94	1/4-28UNF	0.25	0.25	0.71	0.51	0.69
NY-106	25	1.19	0.51	0.94	5/16-24UNF	0.25	0.25	0.71	0.51	0.69
NY125	32-40	1.69	0.75	1.32	7/16-20UNF	0.38	0.38	1.02	0.75	0.94
NY-G050	50, 63	1.69	0.75	1.32	1/2-20UNF	0.38	0.38	1.02	0.75	0.94

CG1 Knuckle Pin

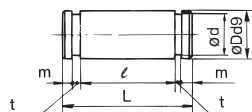

Material: Carbon steel mm

Part no.	Applicable bore (mm)	Dd ₉	L	d	ℓ	m	t	Applicable snap ring
IY-G02	20	8 ^{-0.040} _{-0.076}	21	7.6	16.2	1.5	0.9	Type C 8 for axis
IY-G03	25, 32	10 ^{-0.040} _{-0.076}	25.6	9.6	20.2	1.55	1.15	Type C 10 for axis
IY-G04	40	10 ^{-0.040} _{-0.076}	41.6	9.6	36.2	1.55	1.15	Type C 10 for axis
IY-G05	50, 63	14 ^{-0.050} _{-0.093}	50.6	13.4	44.2	2.05	1.15	Type C 14 for axis
IY-G08	80	18 ^{-0.050} _{-0.093}	64	17	56.2	2.55	1.35	Type C 18 for axis
IY-G10	100	22 ^{-0.065} _{-0.117}	72	21	64.2	2.55	1.35	Type C 22 for axis

NCG Knuckle Pin

Material: Rolled steel inch

Part no.	Applicable bore (mm)	ØD	L	Ød	ℓ	m	t
NCG-SP020	20	0.25	0.83	0.21	0.65	0.06	0.03
NCG-SP025	25	0.25	0.83	0.21	0.65	0.06	0.03
NCG-SP032	32	0.25	0.98	0.21	0.76	0.08	0.03
NCG-SP040	40	0.38	1.24	0.30	1.00	0.08	0.04
NCG-SP050	50	0.38	1.50	0.30	1.24	0.09	0.04
NCG-SP063	63	0.38	1.50	0.30	1.24	0.09	0.04

CG1 Clevis Pin

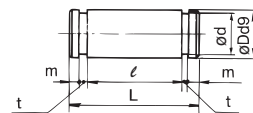

Material: Carbon steel mm

Part no.	Applicable bore (mm)	Dd ₉	L	d	ℓ	m	t	Applicable snap ring
CD-G02	20	8 ^{-0.040} _{-0.076}	43.4	7.6	38.6	1.5	0.9	Type C 8 for axis
CD-G25	25	10 ^{-0.040} _{-0.076}	48	9.6	42.6	1.55	1.15	Type C 10 for axis
CD-G03	32	12 ^{-0.050} _{-0.093}	59.4	11.5	54	1.55	1.15	Type C 12 for axis
CD-G04	40	14 ^{-0.050} _{-0.093}	71.4	13.4	65	2.05	1.15	Type C 14 for axis
CD-G05	50	16 ^{-0.050} _{-0.093}	86	15.2	79.6	2.05	1.15	Type C 16 for axis
CD-G06	63	18 ^{-0.050} _{-0.093}	105.4	17	97.8	2.45	1.35	Type C 18 for axis

* Clevis pin and knuckle pin are common for bore size Ø80 and Ø100.

NCG Clevis Pin

Material: Rolled steel inch

Part no.	Applicable bore (mm)	ØD	L	Ød	ℓ	m	t
NCD-G02	20	0.315	1.71	0.30	1.52	0.06	0.04
NCD-G025	25	0.394	1.89	0.38	1.68	0.06	0.05
NCD-G03	32	0.472	2.34	0.45	2.12	0.08	0.05
NCD-G04	40	0.551	2.81	0.53	2.56	0.08	0.05
NCD-G05	50	0.630	3.38	0.60	3.13	0.08	0.05
NCD-G06	63	0.709	4.15	0.67	3.85	0.10	0.05

CG1 Rod End Nut

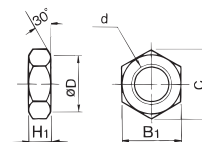

Material: Rolled steel mm

Part no.	Applicable bore (mm)	d	H ₁	B ₁	C	D
NT-02	20	M8 x 1.25	5	13	(15.0)	12.5
NT-03	25, 32	M10 x 1.25	6	17	(19.6)	16.5
NT-G04	40	M14 x 1.5	8	19	(21.9)	18
NT-05	50, 63	M18 x 1.5	11	27	(31.2)	26
NT-08	80	M22 x 1.5	13	32	(37.0)	31
NT-10	100	M26 x 1.5	16	41	(47.3)	39

NCG Rod End Nut

Material: Rolled steel inch

Part no.	Applicable bore (mm)	d	H	B	C
JM-025	20	1/4-28UNF	0.16	0.44	(0.50)
JM-03	25	5/16-24UNF	0.19	0.50	(0.58)
JM-045	32, 40	7/16-20UNF	0.26	0.69	(0.79)
JM-05	50, 63	1/2-2UNF	0.32	0.75	(0.87)

Series NCG/CG1

Accessory Bracket Dimensions

CG1 Double Knuckle Joint

Y-G02/G03
Material: Rolled steel

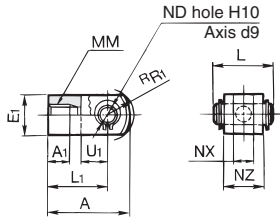

Y-G04/G05/G08/G10
Material: Cast iron

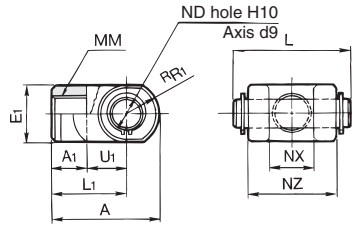

Part no.	Applicable bore (mm)	A	A ₁	E ₁	L ₁	MM	R ₁	U ₁	ND	NX	NZ	L	Applicable pin part no.
Y-G02	20	34	8.5	□16	25	M8 x 1.25	10.3	11.5	8	8 ^{+0.4} _{-0.2}	16	21	IY-G02
Y-G03	25, 32	41	10.5	□20	30	M10 x 1.25	12.8	14	10	10 ^{+0.4} _{-0.2}	20	25.6	IY-G03
Y-G04	40	42	16	∅22	30	M14 x 1.5	12	14	10	18 ^{+0.5} _{-0.3}	36	41.6	IY-G04
Y-G05	50, 63	56	20	∅28	40	M18 x 1.5	16	20	14	22 ^{+0.5} _{-0.3}	44	50.6	IY-G05
Y-G08	80	71	23	∅38	50	M22 x 1.5	21	27	18	28 ^{+0.5} _{-0.3}	56	64	IY-G08
Y-G10	100	79	24	∅44	55	M26 x 1.5	24	31	22	32 ^{+0.5} _{-0.3}	64	72	IY-G10

* Knuckle pin and set ring are shipped together.

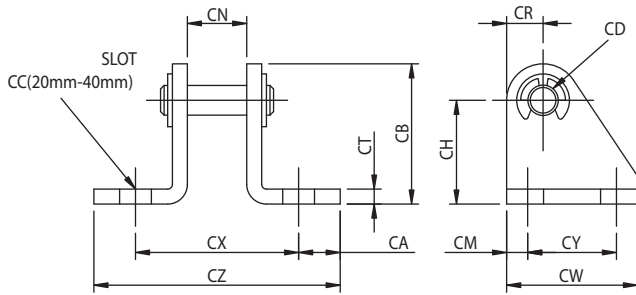

Pivot Bracket (Order separately)

∅20 to ∅63 Material: Rolled steel

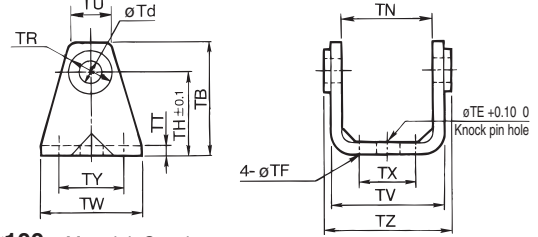

∅80, ∅100 Material: Cast iron

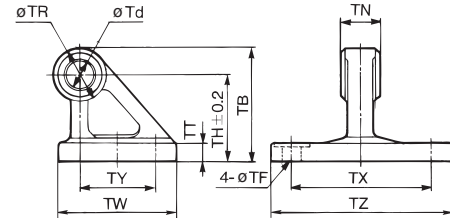

Part no.	Applicable bore (mm)	TB	Td	TE	TF	TH	TN	TR	TT
CG-020-24A	20	36	8	10	5.5	25	(29.3)	13	3.2
CG-025-24A	25	43	10	10	5.5	30	(33.1)	15	3.2
CG-032-24A	32	50	12	10	6.6	35	(40.4)	17	4.5
CG-040-24A	40	58	14	10	6.6	40	(49.2)	21	4.5
CG-050-24A	50	70	16	20	9	50	(60.4)	24	6
CG-063-24A	63	82	18	20	11	60	(74.6)	26	8
CG-080-24A	80	73	18	—	11	55	28 ^{-0.1} _{-0.3}	36	11
CG-100-24A	100	90	22	—	13.5	65	32 ^{-0.1} _{-0.3}	50	12

Part no.	Applicable bore (mm)	TU	TV	TW	TX	TY	TZ	Applicable pin O.D.
CG-020-24A	20	(18.1)	(35.8)	42	16	28	38.3	8d ₉ ^{-0.040} _{-0.076}
CG-025-24A	25	(20.7)	(39.8)	42	20	28	42.1	10d ₉ ^{-0.040} _{-0.076}
CG-032-24A	32	(23.6)	(49.4)	48	22	28	53.8	12d ₉ ^{-0.050} _{-0.093}
CG-040-24A	40	(27.3)	(58.4)	56	30	30	64.6	14d ₉ ^{-0.050} _{-0.093}
CG-050-24A	50	(29.7)	(72.4)	64	36	36	79.2	16d ₉ ^{-0.050} _{-0.093}
CG-063-24A	63	(34.3)	(90.4)	74	46	46	97.2	18d ₉ ^{-0.050} _{-0.093}
CG-080-24A	80	—	—	72	85	45	110	18d ₉ ^{-0.050} _{-0.093}
CG-100-24A	100	—	—	93	100	60	130	22d ₉ ^{-0.065} _{-0.117}

NCG Pivot Bracket

inch

Part no.	Applicable bore (mm)	TB	Td	TE	TF	TH	TN	TR	TT	TU	TV	TW	TX	TY	TZ
NCG-P020	20	1.42	0.315	0.39	0.22	0.98	(1.14)	0.51	0.12	(0.71)	(1.39)	1.65	0.63	1.10	1.50
NCG-P025	25	1.68	0.394	0.39	0.22	1.18	(1.30)	0.59	0.12	(0.81)	(1.55)	1.65	0.79	1.10	1.65
NCG-P032	32	1.97	0.472	0.39	0.27	1.38	(1.57)	0.67	0.18	(0.93)	(1.93)	1.89	0.87	1.10	2.10
NCG-P040	40	2.28	0.551	0.39	0.27	1.57	(1.93)	0.83	0.18	(1.07)	(2.28)	2.20	1.18	1.18	2.53
NCG-P050	50	2.75	0.630	0.79	0.35	1.97	(2.36)	0.91	0.24	(1.17)	(2.83)	2.52	1.42	1.42	3.10
NCG-P063	63	3.23	0.709	0.79	0.43	2.36	(2.91)	0.98	0.31	(1.35)	(3.54)	2.91	1.81	1.81	3.80

NCG Single Clevis Pivot Bracket

inch

Part no.	Applicable bore (mm)	CA	CB	CC	CD	CH	CM	CN	CR	CT	CX	CW	CY	CZ
NCG-PC020	20-25	0.35	1.18	0.27	0.25	0.87	0.18	0.38	0.31	0.12	1.25	1.10	0.75	1.95
NCG-PC032	32	0.35	1.18	0.27	0.25	0.87	0.18	0.50	0.31	0.12	1.37	1.10	0.75	2.07
NCG-PC040	40	0.36	1.75	0.27	0.38	1.38	0.25	0.63	0.37	0.18	1.87	1.50	1.00	2.60
NCG-PC050	50	0.44	1.75	0.76	0.38	1.38	0.25	0.75	0.37	0.24	2.12	1.50	1.00	3.00
NCG-PC063	63	0.44	2.12	0.76	0.38	1.75	0.25	0.75	0.37	0.24	2.12	1.50	1.00	3.00

Air Cylinder: Standard Type Double Acting, Double Rod

Series **NCGW/CG1W**

ø20, ø25, ø32, ø40, ø50, ø63, ø80, ø100

How to Order

Without auto switch NCGW **L** **N** **25** — **04** **00**

With auto switch NCDGW **L** **N** **25** — **04** **00** — **M9NW**

Built-in magnet

Mounting style

B	Basic style
L	Axial foot style
F	Front flange style
U	Front trunnion style

Cushion

N	Urethane cushion
A	Adjustable air cushion

*Nose mount with air cushion is not available in ø20 and ø25mm.

Bore size

20	20 mm (3/4")	40	40 mm (1-1/2")
25	25 mm (1")	50	50 mm (2")
32	32 mm (1-1/4")	63	63 mm (2-1/2")

Stroke Hundredths of an inch*

*Stroke length must be indicated as 4 digits.
First and second digit: Stroke/Inch
Third and fourth digit: Stroke/Hundredth of an inch
Example) 0525=5.25 (5-1/4) inch stroke

Number of auto switches

Nil	2 pcs.
S	1 pc.
n	"n" pcs.

Auto switch

Nil	Without auto switch (Built-in magnet)
------------	---------------------------------------

*For the applicable auto switch model, refer to the table below.

Cylinder stroke (inch)



How to Order

Without auto switch CG1W **L** **N** **25** — **100**

With auto switch CDG1W **L** **N** **25** — **100** — **M9NW**

Built-in magnet

Double acting, double rod type

Mounting style

B	Basic style
L	Axial foot style
F	Rod side flange style
U*	Rod side trunnion style

*Not available for bore size ø80 and ø100.
Note) Mounting brackets are shipped together, (but not assembled).

Type

N	Non-lube/Rubber bumper
A	Non-lube/Air cushion

Bore size

20	20 mm	50	50 mm
25	25 mm	63	63 mm
32	32 mm	80	80 mm
40	40 mm	100	100 mm

Cylinder stroke (mm)

Refer to "Standard Stroke" on Best Pneumatics.

Auto switch

Nil	Without auto switch (Built-in magnet)
------------	---------------------------------------

*For the applicable auto switch model, refer to the table below.

Number of auto switches

Nil	2 pcs.
S	1 pc.
n	"n" pcs.

Suffix for cylinder (Rod boot)

Nil	Without rod boot	
One end	J	Nylon tarpaulin
	K	Heat resistant tarpaulin
Both ends	JJ	Nylon tarpaulin
	KK	Heat resistant tarpaulin

* In the case of w/ rod boot, and a foot bracket or rod side flange as a bracket, those parts are to be assembled at the time of shipment.

Series NCGW/CG1W

Applicable Auto Switch/Refer to Best Pneumatics for further information on auto switches.

Type	Special function	Electrical entry	Indicator light	Wiring (Output)	Load voltage		Auto switch model		Lead wire length (m)*				Pre-wire connector	Applicable load		
					DC	AC	Applicable bore size (mm)		0.5 (Nil)	3 (L)	5 (Z)	None (N)		IC circuit	Relay, PLC	
							20 to 63	80, 100								
Reed switch	—	Grommet	Yes	3-wire (NPN equivalent)	—	5 V	—	C76	—	●	●	—	—	—	—	—
	Diagnostic indication (2-color indication)	Connector		2-wire	24 V	12 V	100 V, 200 V	B54		●	●	●	—	—	—	Relay, PLC
		Grommet	100 V					C73	—	●	●	●	—	—		
			—					C73C	—	●	●	●	●	—		
—	Grommet	—	—	—	—	B59W		●	●	—	—	—	—	—		
Solid state switch	—	Grommet	Yes	3-wire (NPN)	24 V	5 V, 12 V	—	M9N	G59	●	—	○	—	○	IC circuit	Relay, PLC
	3-wire (PNP)			M9P				G5P	●	—	○	—	○			
	2-wire			M9B				K59	●	—	○	—	○			
	3-wire (NPN)			M9NW				G59W	●	●	○	—	○	IC circuit		
	3-wire (PNP)			M9PW				G5PW	●	●	○	—	○	IC circuit		
	2-wire			M9BW				K59W	●	●	○	—	○	—		
	Water resistant (2-color indication)			M9BA				G5BA	●	●	○	—	○	—		
	Diagnostic output (2-color indication)			—				G59F	●	●	○	—	○	IC circuit		

* Lead wire length symbols: 0.5 m..... Nil (Example) C73C M9NW
 3 m..... L (Example) C73CL M9NL
 5 m..... Z (Example) C73CZ M9NZ
 None..... N (Example) C73CN

* Solid state switches marked with "○" are produced upon receipt of order.

- Since there are other applicable auto switches than listed, contact SMC for details.
- For details about auto switches with pre-wire connector, refer to Best Pneumatics.



Air cylinder: Standard Type Double Acting, Single Rod Series NCGW/CG1W

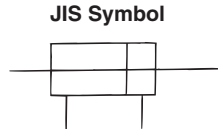

Made to Order Specifications (For details, refer to Best Pneumatics.)

Symbol	Specifications	NCG	CG1
-XA□	Change of rod end shape	●	●
-XB6	Heat resistant cylinder (150°C)	●	●
-XB7	Cold resistant cylinder	●	●
-XC6	Piston rod and rod end nut made of stainless steel	●	●
-XC13	Auto switch rail mounting style	●	●
-XC18	NPT finish piping port		●
-XC22	Fluoro rubber seals		●
-XC37	Large throttle diameter of connecting port	●	●

Accessory

	Mounting	Basic style	Axial foot style	Rod side flange style	Rod side trunnion style
Standard equipment	Rod end nut	●	●	●	●
	Single knuckle joint	●	●	●	●
Option	Double knuckle joint (With pin)**	●	☆	●	●
	Pivot bracket*	—	—	—	●*
	Rod boot	●	●	●	●

* Not available for bore size ø80 and ø100.

** Pin and snap ring are shipped together with double knuckle joint.

Specifications

Bore size (mm)	20	25	32	40	50	63	80	100
Action	Double acting, Double rod							
Type	Non-lube							
Fluid	Air							
Proof pressure	1.5 MPa							
Maximum operating pressure	1.0 MPa							
Minimum operating pressure	0.08 MPa							
Ambient and fluid temperature	Without auto switch: -10 to 70°C (No freezing) With auto switch: -10 to 60°C (No freezing)							
Piston speed	50 to 1000 mm/s						50 to 700 mm/s	
Stroke length tolerance	Up to 1000 mm		mm ^{st+1.4} ₀		Up to 1000 mm			mm ^{st+1.4} ₀
	Up to 1200 mm		mm ^{st+1.8} ₀		Up to 1500 mm			mm ^{st+1.8} ₀
Thread tolerance	JIS Class 2							
Cushion	Rubber bumper, Air cushion							
Mounting*	Basic style, Axial foot style, Rod side flange style, Rod side trunnion style							



* Rod side trunnion style is not available for bore sizes ø80 and ø100.

Standard Stroke (for CG1)

Bore size (mm)	Standard stroke ⁽¹⁾ (mm)	Long stroke (mm)	Maximum manufacturable stroke (mm)
20	25, 50, 75, 100, 125, 150, 200	201 to 350	1500
25		301 to 400	
32		301 to 450	
40	25, 50, 75, 100, 125, 150, 200, 250, 300	301 to 800	
50, 63		301 to 1200	
80		301 to 1400	
100		301 to 1500	

Standard Stroke (for NCG)

Bore size (mm)	Standard stroke ⁽¹⁾ (inch)	Long stroke (inch)	Maximum manufacturable stroke (inch)
20	1, 2, 3, 4, 5, 6, 8	20	76
25		25	
32		40	
40	1, 2, 3, 4, 5, 6, 8, 10, 12	45	
50		55	
63		55	

Note1) Other intermediate strokes can be manufactured upon receipt of an order. Spaces are not used for the intermediate strokes.

Note2) Long stroke applies to the axial foot style and the rod side flange style. If other length exceeds the stroke limit, the stroke should be determined based on the stroke selection table in the technical data.

Other than the applicable auto switches listed in "How to Order", the following auto switches can be mounted. For detailed specifications, refer to Best Pneumatics.

Type	Model	Electrical entry	Features	Applicable bore size (mm)
Reed switch	D-C80	Grommet	Without indicator light	20 to 40
	D-C80C	Connector		
	D-B53	Grommet	Without indicator light	20 to 100
	D-B64			

* Timer equipped type, solid state auto switch (D-G5NTL) is also available.

* Wide range detection type, solid state auto switch (D-G5NBL) is also available.

* With pre-wire connector is available for D-G5NTL and D-G5NBL.

Series NCGW/CG1W

Weight

(kg)

Bore size (mm)		20	25	32	40	50	63	80	100
Basic weight	Basic style	0.13	0.22	0.33	0.55	1.02	1.37	2.64	4.09
	Axial foot style	0.24	0.35	0.49	0.77	1.50	2.09	3.60	5.84
	Flange style	0.21	0.32	0.47	0.75	1.36	1.87	3.35	5.44
	Trunnion style	0.14	0.24	0.36	0.60	1.16	1.51	—	—
Pivot bracket		0.08	0.09	0.17	0.25	0.44	0.80	—	—
Single knuckle joint		0.05	0.09	0.09	0.10	0.22	0.22	0.39	0.57
Double knuckle joint (With pin)		0.05	0.09	0.09	0.13	0.26	0.26	0.64	1.31
Additional weight per each 50 mm of stroke		0.07	0.10	0.13	0.23	0.34	0.38	0.54	0.77
Additional weight with air cushion		0.01	0.01	0.02	0.02	0.03	0.03	0.09	0.10



Precautions

Be sure to read before handling.
Refer to Best Pneumatics for Safety
Instructions and Actuator
Precautions.

Calculation: (Example) CG1WLN32-100 (Foot style, ø32, 100 st)

- Basic weight.....0.49 (Foot, ø32)
- Additional weight.....0.13/50 st
- Cylinder stroke.....100 st
- $0.49 + 0.13 \times 100/50 = 0.75$ kg

Construction

With rubber bumper

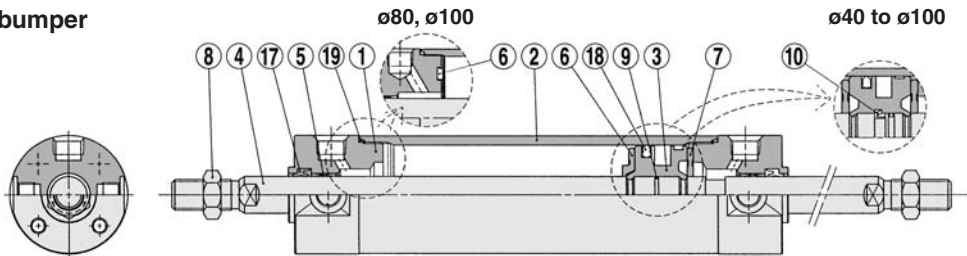

With air cushion

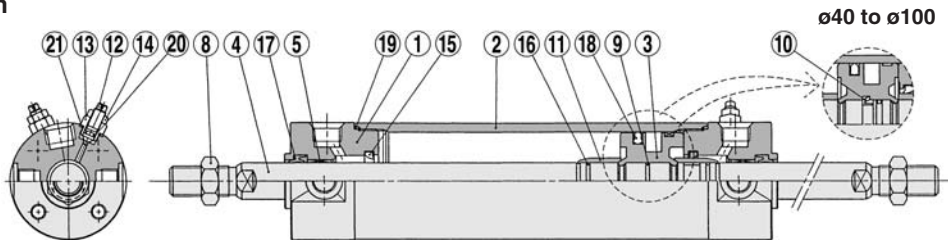

Component Parts

No.	Description	Material	Note
①	Rod cover	Aluminum alloy	Clear hard anodized
②	Cylinder tube	Aluminum alloy	Hard anodized
③	Piston	Aluminum alloy	Chromated
④	Piston rod	Carbon steel *	Hard chrome plated
⑤	Bushing	Oil-impregnated sintered alloy	ø40 and larger are lead-bronze casted
⑥	Bumper A	Urethane	
⑦	Bumper B	Urethane	ø40 or larger: The same as bumper A
⑧	Rod end nut	Rolled steel	Nickel plated
⑨	Piston gasket	NBR	
⑩	Piston holder	Urethane	ø40 or more *
⑪	Cushion ring	Brass	
⑫	Cushion valve	Rolled steel	Electroless nickel plated
⑬	Valve retainer	Rolled steel	Electroless nickel plated
⑭	Lock nut	Carbon steel	Nickel plated
⑮	Cushion seal	Urethane	
⑯	Cushion ring	NBR	
⑰	Cushion valve	NBR	
⑱	Piston seal	NBR	
⑲	Tube gasket	NBR	
⑳	Valve seal	NBR	
㉑	Valve retaining gasket	NBR	

Note) In the case of cylinders with auto switches, magnets are installed in the piston.

* The material is stainless steel on auto switch equipped styles ø20 and ø25.

Replacement Parts/Seal kits are the same as standard type, double acting, single rod. Refer to Best Pneumatics.

Series NCGW/CG1W

Basic Style with Rubber Bumper: CG1WBN

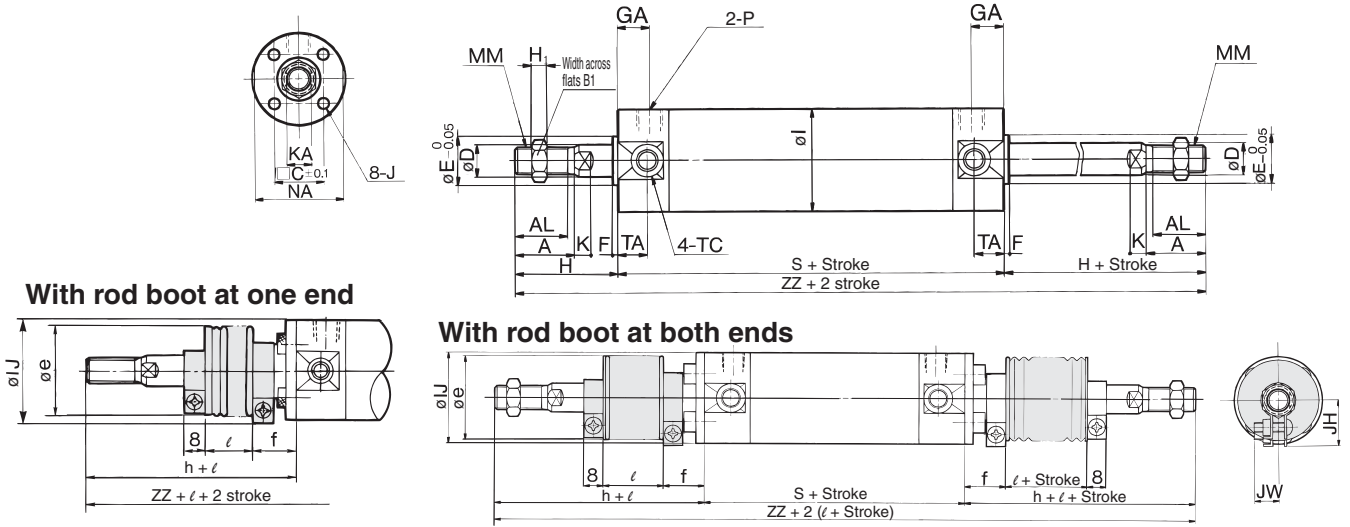

Bore size (mm)	Stroke range (mm)	A	AL	B ₁	C	D	E	F	GA	H ₁	I	J	K	KA	MM	NA	P	S
20	Up to 350	18	15.5	13	14	8	12	2	12	5	26	M4 x 0.7 depth 7	5	6	M8 x 1.25	24	Rc 1/8	77
25	Up to 400	22	19.5	17	16.5	10	14	2	12	6	31	M5 x 0.8 depth 7.5	5.5	8	M10 x 1.25	29	Rc 1/8	77
32	Up to 450	22	19.5	17	20	12	18	2	12	6	38	M5 x 0.8 depth 8	5.5	10	M10 x 1.25	35.5	Rc 1/8	79
40	Up to 800	30	27	19	26	16	25	2	13	8	47	M6 x 1 depth 12	6	14	M14 x 1.5	44	Rc 1/8	87
50	Up to 1200	35	32	27	32	20	30	2	14	11	58	M8 x 1.25 depth 16	7	18	M18 x 1.5	55	Rc 1/4	102
63	Up to 1200	35	32	27	38	20	32	2	14	11	72	M10 x 1.5 depth 16	7	18	M18 x 1.5	69	Rc 1/4	102
80	Up to 1400	40	37	32	50	25	40	3	20	13	89	M10 x 1.5 depth 22	10	22	M22 x 1.5	80	Rc 3/8	122
100	Up to 1500	40	37	41	60	30	50	3	20	16	110	M12 x 1.75 depth 22	10	26	M26 x 1.5	100	Rc 1/2	122

Bore size (mm)	TA	TC**	Without rod boot		With rod boot on one side*							With rod boot on both sides*		Air-hydro		
			H	ZZ	e	f	h	IJ	JH	JW	ℓ	ZZ	ZZ	Bore size (mm)	S	ZZ
20	11	M5 x 0.8	35	147	30	16	55	27	(14.5)	(11.5)	0.25 stroke	167	187	20	77	147
25	11	M6 x 0.75	40	157	30	17	62	32	(17.5)	(11.5)		179	201	25	77	157
32	11	M8 x 1.0	40	159	35	17	62	38	(19.5)	(11.5)		181	203	32	79	159
40	12	M10 x 1.25	50	187	35	17	70	48	(22.5)	(13)		207	227	40	87	187
50	13	M12 x 1.25	58	218	40	17	78	59	(25)	(13)		238	258	50	102	218
63	13	M14 x 1.5	58	218	40	18	78	72	(25)	(13)		238	258	63	102	218
80	—	—	71	264	52	10	80	59	—	—		273	282			
100	—	—	71	264	62	7	80	71	—	—	273	282				

* The minimum stroke with rod boot is 20 mm.
 ** Trunnion mounting taps with width across flats NA are not attached for bore sizes $\phi 80$ and $\phi 100$.

Basic Mount Dimensions: NCGWN

Bore size (mm)	Standard stroke range (mm)	Long stroke range (mm)	A	AL	B ₁	C	D	E	F	GA	H	H ₁	I	J	K	KA	MM
20	Up to 8	8.01 to 14	0.50	0.55	0.44	0.55	0.315	0.472	0.08	0.47	1.00	0.16	1.02	#8-32UNC depth 0.28	0.16	0.24	1/4-28UNF
25	Up to 12	12.01 to 16	0.50	0.55	0.50	0.65	0.394	0.551	0.08	0.47	1.12	0.19	1.22	#10-32UNF depth 0.30	0.20	0.31	5/16UNF
32	Up to 12	12.01 to 18	0.75	0.83	0.69	0.79	0.472	0.709	0.08	0.47	1.63	0.26	1.50	#10-32UNF depth 0.30	0.22	0.39	7/16UNF
40	Up to 12	12.01 to 32	0.75	—	0.69	1.02	0.630	0.984	0.08	0.51	1.63	0.26	1.85	1/4-28UNF depth 0.47	0.30	0.55	7/16UNF
50	Up to 12	12.01 to 48	0.88	—	0.75	1.26	0.787	1.181	0.08	0.55	2.07	0.32	2.28	5/16-24UNF depth 0.63	0.30	0.71	1/2-20UNF
63	Up to 12	12.01 to 48	0.88	—	0.75	1.50	0.787	1.260	0.08	0.55	2.07	0.32	2.83	3/8-24UNF depth 0.63	0.30	0.71	1/2-20UNF

Bore size (mm)	NA	P(NPT)	S	TA	ZZ
20	0.94	1/8	3.03	0.43	5.03
25	1.14	1/8	3.03	0.43	5.27
32	1.40	1/8	3.11	0.43	6.37
40	1.73	1/8	3.38	0.47	6.64
50	2.17	1/4	3.85	0.51	7.99
63	2.72	1/4	3.85	0.51	7.99

Air cylinder: Standard Type Double Acting, Double Rod Series NCGW/CG1W

Basic Style with Air Cushion: CG1WBA

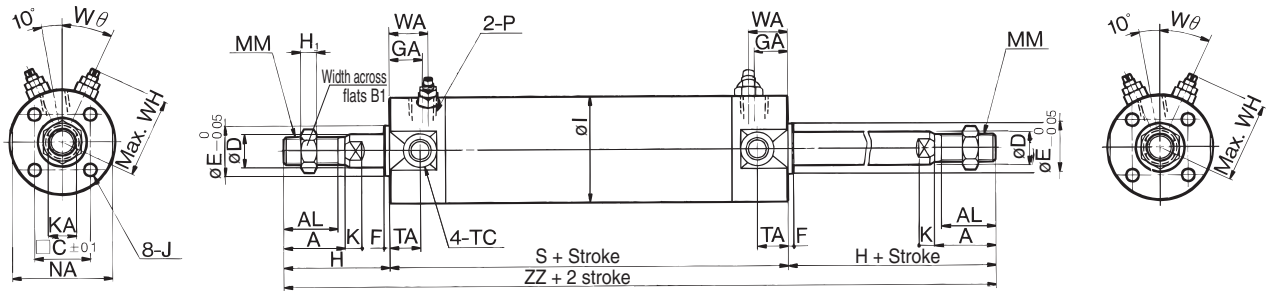

* For the one with rod boot, refer to w/ rubber bumper.

Bore size (mm)	Standard stroke range (mm)	Long stroke range (mm)	A	AL	B ₁	C	D	E	F	GA	H	H ₁	I	J	K	KA
20	Up to 200	201 to 350	18	15.5	13	14	8	12	2	12	35	5	26	M4 x 0.7 depth 7	5	6
25	Up to 300	301 to 400	22	19.5	17	16.5	10	14	2	12	40	6	31	M5 x 0.8 depth 7.5	5.5	8
32	Up to 300	301 to 450	22	19.5	17	20	12	18	2	12	40	6	38	M5 x 0.8 depth 8	5.5	10
40	Up to 300	301 to 800	30	27	19	26	16	25	2	13	50	8	47	M6 x 1 depth 12	6	14
50	Up to 300	301 to 1200	35	32	27	32	20	30	2	14	58	11	58	M8 x 1.25 depth 16	7	18
63	Up to 300	301 to 1200	35	32	27	38	20	32	2	14	58	11	72	M10 x 1.5 depth 16	7	18
80	Up to 300	301 to 1400	40	37	32	50	25	40	3	20	71	13	89	M10 x 1.5 depth 22	10	22
100	Up to 300	301 to 1500	40	37	41	60	30	50	3	20	71	16	110	M12 x 1.75 depth 22	10	26

Bore size (mm)	MM	NA	P	S	TA	TC **	ZZ	WA	WH	Wθ
20	M8 x 1.25	24	M5 x 0.8	77	11	M5 x 0.8	147	16	23	30°
25	M10 x 1.25	29	M5 x 0.8	77	11	M6 x 0.75	157	16	25	30°
32	M10 x 1.25	35.5	Rc 1/8	79	11	M8 x 1.0	159	16	28.5	25°
40	M14 x 1.5	44	Rc 1/8	87	12	M10 x 1.25	187	16	33	20°
50	M18 x 1.5	55	Rc 1/4	102	13	M12 x 1.25	218	18	40.5	20°
63	M18 x 1.5	69	Rc 1/4	102	13	M14 x 1.5	218	18	47.5	20°
80	M22 x 1.5	80	Rc 3/8	122	—	—	264	22	60.5	20°
100	M26 x 1.5	100	Rc 1/2	122	—	—	264	22	71	20°

* For mounting brackets, refer to Best Pneumatics.
** Trunnion mounting taps with width across flats NA are not attached for bore sizes ø80 and ø100.

Basic Mount Dimensions (Inches):NCGWA

Bore size (mm)	Standard stroke range (inch)	Long stroke range (mm)	A	AL	B ₁	C +/-0.004	D	E +/-0.002	F	GA	H	H ₁	I	J	K	KA
20	Up to 8	8.01 to 14	0.50	0.55	0.44	0.55	0.315	0.472	0.08	0.47	1.00	0.16	1.02	#8-32UNC depth 0.28	0.16	0.24
25	Up to 12	12.01 to 16	0.50	0.55	0.50	0.65	0.394	0.551	0.08	0.47	1.12	0.19	1.22	#10-32UNC depth 0.30	0.20	0.31
32	Up to 12	12.01 to 18	0.75	0.83	0.69	0.79	0.472	0.709	0.08	0.47	1.63	0.26	1.50	#10-32UNC depth 0.30	0.22	0.39
40	Up to 12	12.01 to 32	0.75	—	0.69	1.02	0.630	0.984	0.08	0.51	1.63	0.26	1.85	1/4-32UNC depth 0.47	0.30	0.55
50	Up to 12	12.01 to 48	0.88	—	0.75	1.26	0.787	1.181	0.08	0.55	2.07	0.32	2.28	5/16-32UNC depth 0.63	0.30	0.71
63	Up to 12	12.01 to 48	0.88	—	0.75	1.50	0.787	1.260	0.08	0.55	2.07	0.32	2.83	3/8-32UNC depth 0.63	0.30	0.71

Bore size (mm)	MM	NA	P (NPT)	S	TA	TC	ZZ	WA	WH	Wθ
20	1/4-28UNF	0.94	#10-32UNF	3.03	0.43	M5 x 0.8	5.03	0.63	0.91	30°
25	5/16-24UNF	1.14	#10-32UNF	3.03	0.43	M6 x 0.75	5.27	0.63	0.98	30°
32	7/16-20UNF	1.40	1/8	3.11	0.43	M8 x 1.0	6.37	0.63	1.12	25°
40	7/16-20UNF	1.73	1/8	3.38	0.47	M10 x 1.25	6.64	0.63	1.30	20°
50	1/2-20UNF	2.17	1/4	3.85	0.51	M12 x 1.25	7.99	0.71	1.59	20°
63	1/2-20UNF	2.72	1/4	3.85	0.51	M14 x 1.5	7.99	0.71	1.87	20°

Note) Refer to Model Selection Charts in Best Pneumatics for acceptable loading for long stroke cylinders

Series CG1W/NCGW

With Mounting Bracket

Axial foot style: CG1WLN

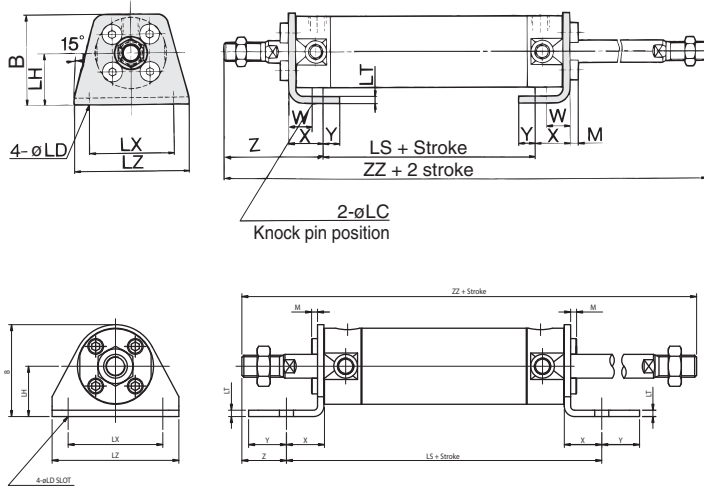

Rod side flange style: CG1WFN

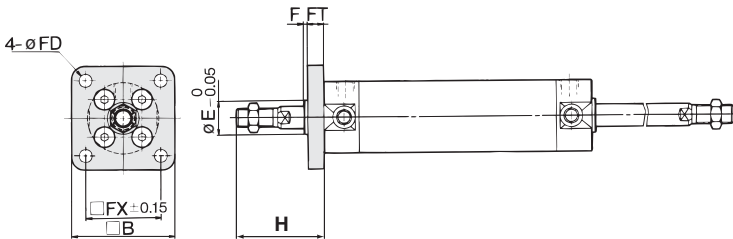

Rod side trunnion style: CG1WUN

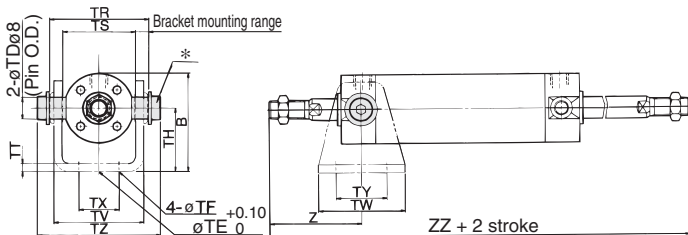

CG1W Mounting Bracket Part No.

Mounting bracket	Bore size (mm)							
	20	25	32	40	50	63	80	100
Axial foot *	CG-L020	CG-L025	CG-L032	CG-L040	CG-L050	CG-L063	CG-L080	CG-L100
Flange	CG-F020	CG-F025	CG-F032	CG-F040	CG-F050	CG-F063	CG-F080	CG-F100
Trunnion pin	CG-T020	CG-T025	CG-T032	CG-T040	CG-T050	CG-T063	—	—
Pivot bracket	CG-020 -24A	CG-025 -24A	CG-032 -24A	CG-040 -24A	CG-050 -24A	CG-063 -24A	—	—

* Order two foot brackets per cylinder.

** Mounting bolts are shipped together for foot style and flange style.

Foot Style

Bore size (mm)	Stroke range (mm)	B	LC	LD	LH	LS	LT	LX	LZ	M	W	X	Y	Z
20	Up to 350	34	4	6	20	53	3	32	44	3	10	15	7	47
25	Up to 400	38.5	4	6	22	53	3	36	49	3.5	10	15	7	52
32	Up to 450	45	4	7	25	53	3	44	58	3.5	10	16	8	53
40	Up to 800	54.5	4	7	30	60	3	54	71	4	10	16.5	8.5	63.5
50	Up to 1200	70.5	5	10	40	67	4.5	66	86	5	17.5	22	11	75.5
63	Up to 1200	82.5	5	12	45	67	4.5	82	106	5	17.5	22	13	75.5
80	Up to 1400	101	6	11	55	74	4.5	100	125	5	20	28.5	14	95
100	Up to 1500	121	6	14	65	74	6	120	150	7	20	30	16	95

* Other dimensions are the same as basic style.

Rod Side Flange Style

Bore size (mm)	Stroke range (mm)	B	E	F	FX	FD	FT	H
20	Up to 350	40	12	2	28	5.5	6	35
25	Up to 400	44	14	2	32	5.5	7	40
32	Up to 450	53	18	2	38	6.6	7	40
40	Up to 800	61	25	2	46	6.6	8	50
50	Up to 1200	76	30	2	58	9	9	58
63	Up to 1200	92	32	2	70	11	9	58
80	Up to 1400	104	40	3	82	11	11	71
100	Up to 1500	128	50	3	100	14	14	71

* End boss is machined on the flange for øE.

* Other dimensions are the same as basic style.

Rod Side Trunnion Style

Bore size (mm)	Stroke range (mm)	B	TDe8	TE	TF	TH	TR	TS
20	Up to 200	38	8 ^{+0.025} _{-0.047}	10	5.5	25	39	28
25	Up to 300	45.5	10 ^{+0.025} _{-0.047}	10	5.5	30	43	33
32	Up to 300	54	12 ^{+0.032} _{-0.059}	10	6.6	35	54.5	40
40	Up to 500	63.5	14 ^{+0.032} _{-0.059}	10	6.6	40	65.5	49
50	Up to 600	79	16 ^{+0.032} _{-0.059}	20	9	50	80	60
63	Up to 600	96	18 ^{+0.032} _{-0.059}	20	11	60	98	74

Bore size (mm)	TT	TV	TW	TX	TY	TZ	Z	
							Without rod boot	With rod boot
20	3.2	(35.8)	42	16	28	47.6	46	66 + ℓ
25	3.2	(39.8)	42	20	28	53	51	73 + ℓ
32	4.5	(49.4)	48	22	28	67.7	51	73 + ℓ
40	4.5	(58.4)	56	30	30	78.7	62	82 + ℓ
50	6	(72.4)	64	36	36	98.6	71	91 + ℓ
63	8	(90.4)	74	46	46	119.2	71	91 + ℓ

* Consists of pin, flat washer and hexagon socket head cap bolt.

* Other dimensions are the same as basic style.



* Mounting screws set made of stainless steel

The following set of mounting screws made of stainless steel is also available. Use it in accordance with the operating environment.

(A switch mounting band is not included, so please order it separately.)

BBA3: For D-B5/B6/G5/K5

BBA4: For D-C7/C8/H7

• D-G5BAL and D-H7BAL switches are set on the cylinder with the stainless steel screws above when shipped.

When only a switch is shipped independently, BBA3 or BBA4 screws are attached.

Air Cylinder: Standard Type Double Acting, Double Rod *Series CG1W/NCGW*

With Mounting Bracket

NCGW Axial Foot Mount Dimensions (Inches)

Bore size (mm)	Stroke range (mm)	B	LD	LH	LS	LT	LX	LZ	M	W	X	Y	Z	ZZ
20	Up to 14	1.44	0.27	0.81	4.13	0.12	1.50	1.88	0.16	1.02	0.56	0.44	0.44	5.01
25	Up to 16	1.52	0.27	0.81	4.13	0.12	1.50	1.88	0.19	1.22	0.56	0.44	0.56	5.13
32	Up to 18	1.83	0.28	1.00	4.59	0.12	1.88	2.50	0.26	1.50	0.75	0.75	0.88	6.22
40	Up to 32	2.02	0.28	1.00	4.86	0.12	1.88	2.50	0.26	1.85	0.72	0.78	0.91	6.55
50	Up to 48	2.84	0.34	1.50	6.01	0.25	2.25	3.12	0.32	2.28	0.62	0.62	1.07	7.70
63	Up to 48	3.29	0.34	1.75	6.01	0.25	2.88	3.75	0.32	2.83	0.62	0.62	1.07	7.70

* Other dimensions are the same as basic style.

NCGW Flange Mount Dimensions (Inches)

Bore size (mm)	Stroke range (mm)	B	E	F	FX	FD	FT	H
20	Up to 14	1.57	0.472 +0/0.0011	0.08	1.10	0.22	0.24	1.00
25	Up to 16	1.73	0.551 +0/0.0011	0.08	1.26	0.22	0.28	1.12
32	Up to 18	2.09	0.709 +0/0.0011	0.08	1.50	0.28	0.28	1.63
40	Up to 32	2.40	0.984 +0/0.0013	0.08	1.81	0.28	0.31	1.63
50	Up to 48	3.00	1.181 +0/0.0013	0.08	2.28	0.35	0.35	2.07
63	Up to 48	3.62	1.260 +0/0.0015	0.08	2.76	0.43	0.35	2.07

* Other dimensions are the same as basic style.

NCGW Rod Side Trunnion Style

Bore size (mm)	Stroke range (mm)	B	TDe8	TE	TF	TH	TR	TS	TT	TV	TW	TX	TY	Z	ZZ
20	Up to 8	1.50	0.315 ^{-0.0009} _{-0.00019}	0.39	0.22	0.98	1.54	1.10	0.13	(1.41)	1.65	0.63	1.10	1.43	5.03
25	Up to 12	1.79	0.394 ^{-0.0009} _{-0.00019}	0.39	0.22	1.18	1.69	1.30	0.13	(1.57)	1.65	0.79	1.10	1.55	5.27
32	Up to 12	2.13	0.472 ^{-0.0013} _{-0.0023}	0.39	0.26	1.38	2.15	1.57	0.18	(1.94)	1.89	0.87	1.10	2.06	6.37
40	Up to 20	2.50	0.551 ^{-0.0013} _{-0.0023}	0.39	0.26	1.57	2.58	1.93	0.18	(2.30)	2.20	1.18	1.18	2.10	6.64
50	Up to 24	3.11	0.630 ^{-0.0013} _{-0.0023}	0.79	0.35	1.97	3.15	2.36	0.24	(2.85)	2.52	1.42	1.42	2.58	7.99
63	Up to 24	3.78	0.709 ^{-0.0013} _{-0.0023}	0.79	0.43	2.36	3.86	2.91	0.31	(3.56)	2.91	1.81	1.81	2.58	7.99

Auto Switch Mounting Bracket Part No.

Auto switch model	Bore size (mm)							
	20	25	32	40	50	63	80	100
D-C7/C8	BMA2-020	BMA2-025	BMA2-032	BMA2-040	BMA2-050	BMA2-063	—	—
D-B5/B6	BA-01	BA-02	BA-32	BA-04	BA-05	BA-06	BA-08	BA-10
D-G5/K5								
D-M9	BMA2-020	BMA2-025	BMA2-032	BMA2-040	BMA2-050	BMA2-063	—	—
BJ3-1 (Adaptor piece)								



* Mounting screws set made of stainless steel

The following set of mounting screws made of stainless steel is also available. Use it in accordance with the operating environment.

(A switch mounting band is not included, so please order it separately.)

NCGW Mounting Bracket Part No.

Mounting Bracket	Bore size (mm)						
	20	25	32	40	50	53	
Foot	NCG-L020	NCG-L025	NCG-L032	NCG-L040	NCG-L050	NCG-L063	
Flange	NCG-F020	NCG-F025	NCG-F032	NCG-F040	NCG-F050	NCG-F063	
Trunnion	NCG-T020	CG-T025	CG-T032	NCG-T040	NCG-T050	NCG-T063	
Trunnion Bracket	NCG-P020	NCG-P025	NCG-P032	NCG-P040	NCG-P050	NCG-P063	

Air Cylinder: Standard Type

Single Acting, Single Rod, Spring Return/Extend

Series *NCG/CG1*

ø20, ø25, ø32, ø40

How to Order

Without auto switch NCG L N 25 — 04 00 S

With auto switch NCDG L N 25 — 04 00 S — M9NW

Built-in magnet

Mounting style

B	Basic style	U	Front trunnion style
C	Single clevis	T	Rear trunnion style
L	Axial foot style	D	Double Clevis style
F	Front flange style	N*	Front nose mount
G	Rear flange style		

Cushion

N	Urethane cushion
----------	------------------

*Nose mount with air cushion is not available in ø20 and ø25mm.

Bore size

20	20 mm (3/4")
25	25 mm (1")
32	32 mm (1-1/4")
40	40 mm (1-1/2")

Stroke
Hundredths of an inch*

*Stroke length must be indicated as 4 digits.
First and second digit: Stroke/Inch
Third and fourth digit: Stroke/Hundredth of an inch
Example) 0525=5.25 (5-1/4) inch stroke

Number of auto switches

Nil	2 pcs.
S	1 pc.
n	"n" pcs.

Auto switch

Nil	Without auto switch (Built-in magnet)
------------	---------------------------------------

*For the applicable auto switch model, refer to the table below.

Action

S	Single acting, Spring return
T	Single acting, Spring extend

Cylinder stroke (inch)



How to Order

Without auto switch CG1 L N 25 — 100 S

With auto switch CDG1 L N 25 — 100 S — M9NW

Built-in magnet

Mounting style

B	Basic style	U	Rod side trunnion
L	Axial foot style	T	Head side trunnion
F	Rod side flange	D	Clevis style
G	Head side flange		

Note) Mounting brackets are shipped together, but not assembled.

Type

N	Non-lube/Rubber bumper
----------	------------------------

Bore size

20	20 mm
25	25 mm
32	32 mm
40	40 mm

Number of auto switches

Nil	2 pcs.
S	1 pc.
n	"n" pcs.

Auto switch

Nil	Without auto switch (Built-in magnet)
------------	---------------------------------------

*For the applicable auto switch model, refer to the table on next page.

Action

S	Single acting, Spring return
T	Single acting, Spring extend

Cylinder stroke (mm)

Air Cylinder: Standard Type
Single Acting, Single Rod, Spring Return/Extend *Series NCG/CG1*

Applicable Auto Switch/Refer to Best Pneumatics for further information on auto switches.

Type	Special function	Electrical entry	Indicator light	Wiring (Output)	Load voltage		Auto switch model		Lead wire length (m)*				Pre-wire connector	Applicable load		
					DC	AC	Applicable bore size (mm)		0.5 (Nil)	3 (L)	5 (Z)	None (N)				
							20 to 63	80, 100								
Reed switch	—	Grommet	Yes	3-wire (NPN equivalent)	—	5 V	—	C76	—	●	●	—	—	—	IC circuit	—
		Connector		2-wire	24 V	12 V	100 V, 200 V	B54		●	●	●	—	—	—	
	Diagnostic indication (2-color indication)	Grommet					—	—	100 V	C73	—	●	●	●		—
					—	—			C73C	—	●	●	●	●		—
Solid state switch	—	Grommet	Yes	3-wire (NPN)	24 V	5 V, 12 V	—	M9N	G59	●	—	○	—	○	IC circuit	Relay, PLC
				3-wire (PNP)				M9P	G5P	●	—	○	—	○		
	2-wire			12 V		M9B		K59	●	—	○	—	○			
	3-wire (NPN)					5 V, 12 V		M9NW	G59W	●	●	○	—	○		
	3-wire (PNP)			M9PW				G5PW	●	●	○	—	○			
	2-wire			12 V		M9BW		K59W	●	●	○	—	○			
	Water resistant (2-color indication)			5 V, 12 V		M9BA		G5BA	●	●	○	—	○			
	Diagnostic output (2-color indication)					—		G59F	●	●	○	—	○			

* Lead wire length symbols: 0.5 m Nil (Example) C73C M9NW
 3 m L (Example) C73CL M9NL
 5 m Z (Example) C73CZ M9NZ
 None N (Example) C73CN

* Solid state switches marked with “○” are produced upon receipt of order.

- Since there are other applicable auto switches than listed, contact SMC for details.
- For details about auto switches with pre-wire connector, refer to Best Pneumatics.

Series NCG/GC1



JIS Symbol

Spring return

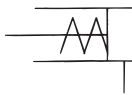

Spring extend

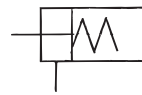

Standard Stroke (for CG1)

Bore size (mm)	Standard stroke (mm) ^{Note)}
20	25, 50, 75, 100, 125
25, 32, 40	25, 50, 75, 100, 125, 150, 200

Note) Intermediate strokes other than the above are produced upon receipt of order. Spacers are not used for intermediate strokes.

Standard Stroke (for NCG)

Bore size (mm)	Standard stroke (inch)
20	1, 2, 3, 4, 5
25, 32, 40	1, 2, 3, 4, 5, 6, 8



Made to Order Specifications

Symbol	Specifications	NCG	CG1
-XC6	Piston rod and rod end nut made of stainless steel	●	●
-XC18	NPT finish piping port		●
-XC20	Head cover axial port		●

CG1 Mounting Bracket Part No.

Mounting bracket	Bore size (mm)			
	20	25	32	40
Axial foot *	CG-L020	CG-L025	CG-L032	CG-L040
Flange	CG-F020	CG-F025	CG-F032	CG-F040
Trunnion pin	CG-T020	CG-T025	CG-T032	CG-T040
Clevis *	CG-D020	CG-D025	CG-D032	CG-D040
Pivot bracket	CG-020-24A	CG-025-24A	CG-032-24A	CG-040-24A

*Order two foot brackets per cylinder.

**Mounting bolt is shipped together with foot style and flange style, and clevis pin, snap ring and mounting bolt with clevis style.

Specifications

Action	Single acting, Spring return	Single acting, Spring extend
Bore size (mm)	20, 25, 32, 40	
Type	Non-lube	
Fluid	Air	
Proof pressure	1.5 MPa	
Maximum operating pressure	1.0 MPa	
Minimum operating pressure	0.18 MPa	0.23 MPa
Ambient and fluid temperature	Without auto switch: -10 to 70°C (No freezing) With auto switch: -10 to 60°C (No freezing)	
Piston speed	50 to 1000 mm/s	
Stroke length tolerance	Up to 200 ^{st+1.4} mm	
Thread tolerance	JIS Class 2	
Cushion	Rubber bumper	
Mounting	Basic style, Axial foot style, Rod side flange style, Head side flange style, Rod side trunnion style, Head side trunnion style, Clevis style (Used for changing the port location by 90°.)	

Accessory

Mounting		Basic style	Axial foot style	Rod side flange style	Head side flange style	Rod side trunnion style	Head side trunnion style	Clevis style
Standard equipment	Rod end nut	●	●	●	●	●	●	●
	Clevis pin	—	—	—	—	—	—	●
Option	Single knuckle joint	●	●	●	●	●	●	●
	Double knuckle joint* (With pin)	●	●	●	●	●	●	●
	Pivot bracket	—	—	—	—	●	●	●

* Pin and snap ring are shipped together with double knuckle joint.

Auto Switch Mounting Bracket Part No.

Auto switch model	Bore size (mm)			
	20	25	32	40
D-C7/C8	BMA2-020	BMA2-025	BMA2-032	BMA2-040
D-B5/B6	BA-01	BA-02	BA-32	BA-04
D-G5/K5				
D-M9	BMA2-020	BMA2-025	BMA2-032	BMA2-040
	BJ3-1 (Adaptor piece)			



* Mounting screws set made of stainless steel
The following set of mounting screws made of stainless steel is also available. Use it in accordance with the operating environment.
(A switch mounting band is not included, so please order it separately.)

NCG Mounting Bracket Part No.

Mounting bracket	Cylinder nominal size inch (Bore size mm)			
	3/4" (20)	1" (25)	1-1/4" (32)	1-1/2" (40)
Foot	NCG-L020	NCG-L025	NCG-L032	NCG-L040
Flange	NCG-F020	NCG-F025	NCG-F032	NCG-F040
Trunnion	NCG-T020	CG-T025	CG-T032	NCG-T040
Trunnion bracket	NCG-P020	NCG-P025	NCG-P032	NCG-P040
Double clevis	NCG-D020	NCG-D025	NCG-D032	NCG-D040
Single clevis	NCG-C020	NCG-C025	NCG-C032	NCG-C040

Air Cylinder: Standard Type Series **NCG/CG1**

Single Acting, Single Rod, Spring Return/Extend

Weight

(kg)

Spring return					
Bore size (mm)		20	25	32	40
Basic weight	25 stroke	0.17	0.27	0.40	0.63
	50 stroke	0.19	0.30	0.45	0.71
	75 stroke	0.26	0.40	0.58	0.91
	100 stroke	0.28	0.43	0.62	0.99
	125 stroke	0.35	0.53	0.76	1.20
	150 stroke	—	0.56	0.81	1.28
	200 stroke	—	0.69	0.98	1.56
Mounting bracket weight	Axial foot style	0.11	0.13	0.16	0.22
	Flange style	0.08	0.10	0.14	0.20
	Trunnion style	0.01	0.02	0.03	0.05
	Clevis style	0.05	0.08	0.15	0.23
Accessory bracket	Pivot bracket	0.08	0.09	0.17	0.25
	Single knuckle joint	0.05	0.09	0.09	0.10
	Double knuckle (With pin)	0.05	0.09	0.09	0.13

Spring extend					
Bore size (mm)		20	25	32	40
Basic weight	25 stroke	0.16	0.25	0.38	0.59
	50 stroke	0.18	0.28	0.43	0.67
	75 stroke	0.24	0.37	0.54	0.83
	100 stroke	0.26	0.40	0.58	0.91
	125 stroke	0.32	0.48	0.69	1.08
	150 stroke	—	0.50	0.72	1.12
	200 stroke	—	0.63	0.89	1.40
Mounting bracket weight	Axial foot style	0.11	0.13	0.16	0.22
	Flange style	0.08	0.10	0.14	0.20
	Trunnion style	0.01	0.02	0.03	0.05
	Clevis style	0.05	0.08	0.15	0.23
Accessory bracket	Pivot bracket	0.08	0.09	0.17	0.25
	Single knuckle joint	0.05	0.09	0.09	0.10
	Double knuckle (With pin)	0.05	0.09	0.09	0.13

Calculation: (Example) CG1LN20-100S (Foot style, ø20, 100 st)
 • Basic weight.....0.28 kg (ø20) • Mounting bracket weight.....0.11 kg (Foot)
 0.28 + 0.11 = 0.39 kg

Calculation: (Example) CG1LN20-100T (Foot style, ø20, 100 st)
 • Basic weight.....0.26 kg (ø20) • Mounting bracket weight....0.11 kg (Foot)
 0.26 + 0.11 = 0.37 kg

Construction

Single acting, Spring return

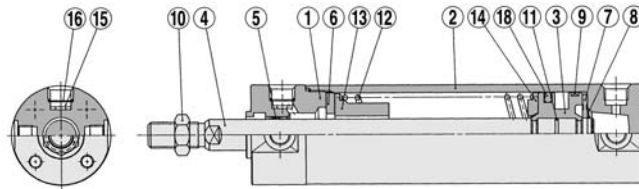

Single acting, Spring extend

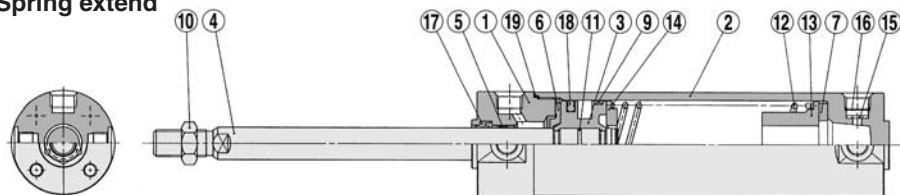

Component Parts

No.	Description	Material	Note
①	Rod cover	Aluminum alloy	Clear hard anodized
②	Tube cover	Aluminum alloy	Clear hard anodized
③	Piston	Aluminum alloy	Chromated
④	Piston rod	Carbon steel *	Hard chrome plated
⑤	Bushing	Oil-impregnated sintered alloy	ø40 is lead-bronze casted
⑥	Bumper A	Urethane	
⑦	Bumper B	Urethane	
⑧	Snap ring	Stainless steel	
⑨	Wear ring	Resin	
⑩	Rod end nut	Rolled steel	Nickel plated
⑪	Piston gasket	NBR	
⑫	Return spring	Steel wire	Zinc chromated
⑬	Spring guide	Aluminum alloy	Chromated
⑭	Spring seat	Aluminum alloy	Chromated
⑮	Element	Sintered metallic BC	
⑯	Snap ring	Copper wire	
⑰	Rod seal	NBR	
⑱	Piston seal	NBR	
⑲	Tube gasket	NBR	

Replacement Parts: For Single Acting, Spring Return

No.	Description	Material	Part no.			
			20	25	32	40
⑱	Piston seal	NBR	PPD-20	PPD-25-19	PPD-32	PPD-40

Replacement Parts: For Single Acting, Spring Extend

Replacement parts/Seal kits are the same as standard type, double acting, single rod (with rubber bumper).

Note) In the case of cylinders with auto switches, rubber magnets are installed in the piston.

*The material is stainless steel on auto switch equipped styles ø20 and ø25.

Series NCG/CG1

Basic Style

Spring return: NCGBN/CG1BN

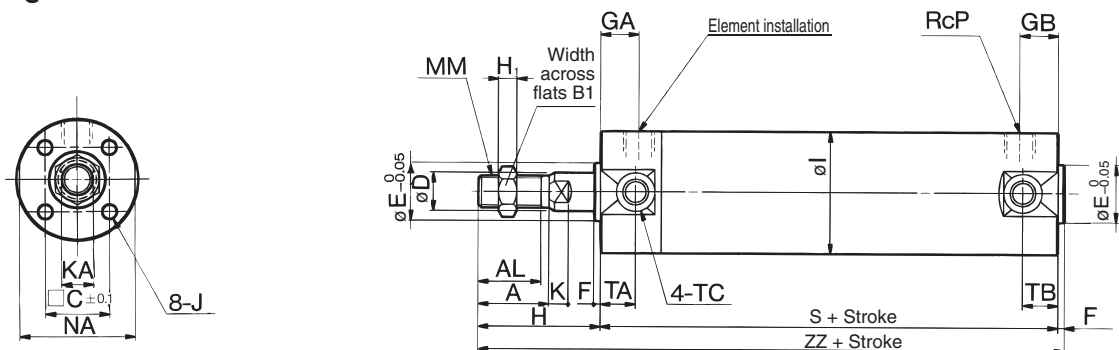

Spring extend: NCGBN/CG1BN

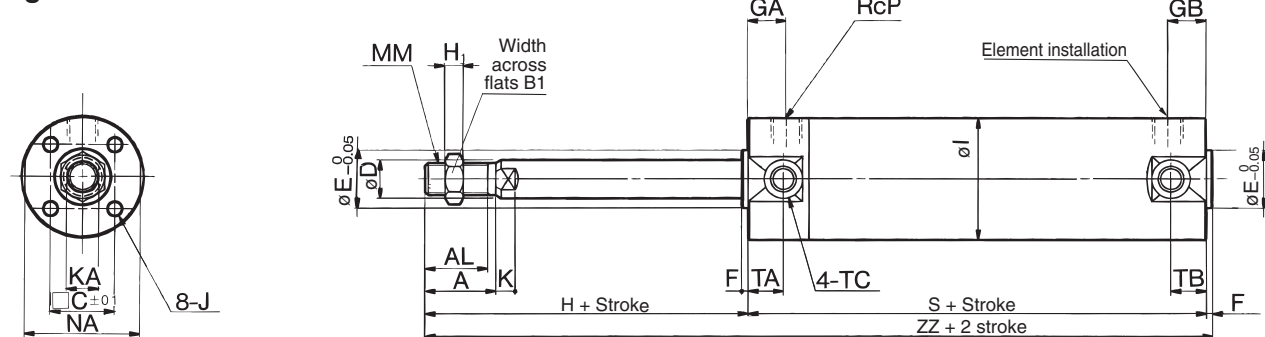

CGI Single Acting Basic Style

Bore size (mm)	Stroke range (mm)	A	AL	B1	C	D	E	F	GA	GB	H	H1	I	J	K	KA	MM	NA	P
20	Up to 125	18	15.5	13	14	8	12	2	12	10	35	5	26	M4 x 0.7 depth 7	5	6	M8 x 1.25	24	1/8
25	Up to 200	22	19.5	17	16.5	10	14	2	12	10	40	6	31	M5 x 0.8 depth 7.5	5.5	8	M10 x 1.25	29	1/8
32	Up to 200	22	19.5	17	20	12	18	2	12	10	40	6	38	M5 x 0.8 depth 8	5.5	10	M10 x 1.25	35.5	1/8
40	Up to 200	30	27	19	26	16	25	2	13	10	50	8	47	M6 x 1 depth 12	6	14	M14 x 1.5	44	1/8

Bore size (mm)	TA	TB	TC	1 to 50 st		51 to 100 st		101 to 125 st		126 to 200 st	
				S	ZZ	S	ZZ	S	ZZ	S	ZZ
20	11	11	M5 x 0.8	94	131	119	156	144	181	—	—
25	11	11	M6 x 0.75	94	136	119	161	144	186	169	211
32	11	10	M8 x 1.0	96	138	121	163	146	188	171	213
40	12	10	M10 x 1.25	103	155	128	180	153	205	178	230

NCG Single Acting Basic Mount Dimensions (Inches)

Bore Size (mm)	Standard stroke range (inch)	Long stroke range (inch)	A	AL	B1	C +/-0.004	D	E +/-0.002	F	GA	GB	H	H1	I	J
20	Up to 5	8.01 to 14	0.55	0.50	0.44	0.55	0.315	0.472	0.08	0.47	0.39 (0.47)	1.00	0.16	1.02	#8-32UNC depth 0.28
25	Up to 8	12.01 to 16	0.55	0.50	0.50	0.65	0.394	0.551	0.08	0.47	0.39 (0.47)	1.12	0.19	1.22	#10-32UNF depth 0.30
32	Up to 8	12.01 to 18	0.83	0.75	0.69	0.79	0.472	0.709	0.08	0.47	0.39 (0.47)	1.63	0.26	1.50	#10-32UNF depth 0.30
40	Up to 8	12.01 to 32	0.75	-	0.69	1.02	0.630	0.984	0.08	0.51	0.39 (0.51)	1.63	0.26	1.85	1/4-28UNF depth 0.47

Bore Size (mm)	K	KA	MM	NA	P (NPT)	TA	TB	TC	0" to 2" st		2.01" to 4" st		4.01" to 5" st		5.01" to 8" st	
									S	ZZ	S	ZZ	S	ZZ	S	ZZ
20	0.16	0.24	1/4-28UNF	0.94	1/8	0.43	0.43	M5x0.8	3.72	4.25	4.72	5.25	5.72	6.25	-	-
25	0.20	0.31	5/16-24UNF	1.14	1/8	0.43	0.43	M6x0.75	3.72	4.37	4.72	5.37	5.72	6.37	6.72	7.37
32	0.22	0.39	7/16-20UNF	1.40	1/8	0.43	0.39 (0.43)	M8x1.0	3.80	4.68	4.80	5.68	5.80	6.68	6.80	7.68
40	0.30	0.55	7/16-20UNF	1.73	1/8	0.47	0.39 (0.47)	M10x1.25	4.07	5.03	5.07	6.03	6.07	7.03	7.07	8.03

Note) (): Denotes the dimensions for long stroke
Refer to Model Selection Charts in Best Pneumatics for acceptable loading for long stroke cylinders

Air Cylinder: Standard Type
Single Acting, Single Rod, Spring Return/Extend

Series NCG/CG1

With Mounting Bracket

Note) The drawing below shows the single acting/spring return style. The rod is in retracted state for spring extend type.

Axial foot style: CG1LN

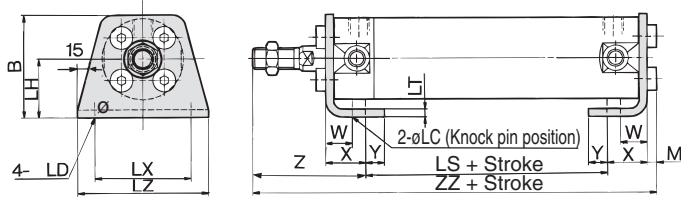

CG1 Single Acting

Bore size (mm)	Stroke range (mm)	B	M	LC	LD	LH	LT	LX	LZ	W	X	Y	Z
20	Up to 125	34	3	4	6	20	3	32	44	10	15	7	47
25	Up to 200	38.5	3.5	4	6	22	3	36	49	10	15	7	52
32	Up to 200	45	3.5	4	7	25	3	44	58	10	16	8	53
40	Up to 200	54.5	4	4	7	30	3	54	71	10	16.5	8.5	63.5

Bore size (mm)	1 to 50 st		51 to 100 st		101 to 125 st		126 to 200 st	
	LS	ZZ	LS	ZZ	LS	ZZ	LS	ZZ
20	70	135	95	160	120	185	—	—
25	70	140.5	95	165.5	120	190.5	145	215.5
32	70	142.5	95	167.5	120	192.5	145	217.5
40	76	160	101	185	126	210	151	235

* Other dimensions are the same as basic style.

NCG Single Acting Axial Foot Mount Dimensions (Inches)

Bore Size (mm)	Standard stroke range (inch)	B	LD	LH	LT	LX	LZ	M	W	X	Y	Z
20	Up to 5"	1.44	0.27	0.81	0.12	1.50	1.88	0.16	1.02	0.56	0.44	0.44
25	Up to 8"	1.52	0.27	0.81	0.12	1.50	1.88	0.19	1.22	0.56	0.44	0.56
32	Up to 8"	1.83	0.28	1.00	0.12	1.88	2.50	0.26	1.50	0.75	0.75	0.88
40	Up to 8"	2.02	0.28	1.00	0.12	1.88	2.50	0.26	1.85	0.72	0.78	0.91

Bore Size (mm)	0" to 2" st		2.01" to 4" st		4.01" to 5" st		5.01" to 8" st	
	S	ZZ	S	ZZ	S	ZZ	S	ZZ
20	4.82	5.70	5.82	6.70	6.82	7.70	—	—
25	4.82	5.82	5.82	6.82	6.82	7.82	7.82	8.82
32	5.28	6.91	6.28	7.91	7.28	8.91	8.28	9.91
40	5.50	7.19	6.50	8.19	7.50	9.19	8.50	10.19

* Other dimensions are the same as basic style

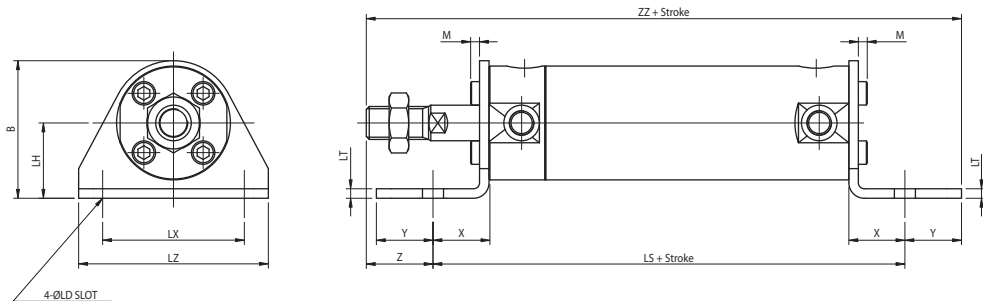

Series CG1

With Mounting Bracket

Rod side flange style: NCGFN/CG1FN

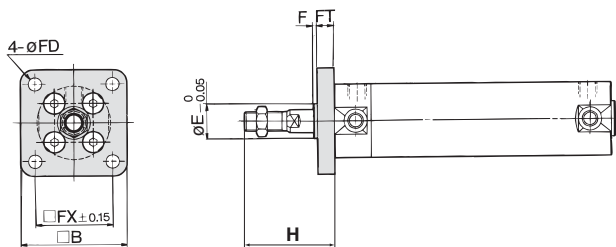

Head side flange style: NCGGN/CG1GN

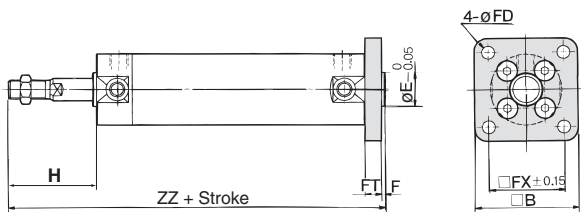

Rod side trunnion style: NCGUN/CG1UN

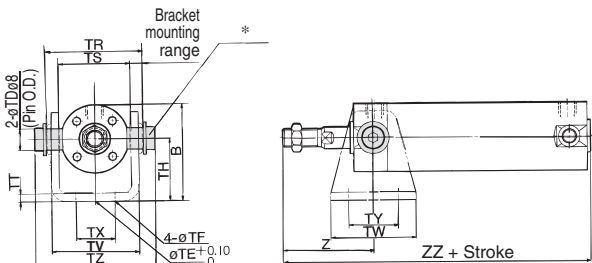

* Clevis pin and snap ring are shipped together.

Head side trunnion style: NCGTN/CG1TN

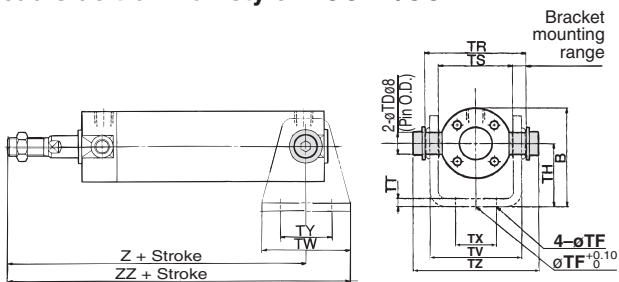

Clevis style: NCGDN/CG1DN

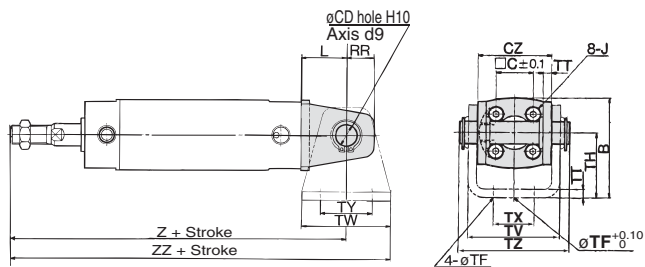

(The above shows the case port location is changed by 90°.)

CG1 Flange Style

mm

Bore size (mm)	Stroke range (mm)	B	E	F	FX	FD	FT	H
20	Up to 125	40	12	2	28	5.5	6	35
25	Up to 200	44	14	2	32	5.5	7	40
32	Up to 200	53	18	2	38	6.6	7	40
40	Up to 200	61	25	2	46	6.6	8	50

* End boss is machined on the flange for øE.

* Other dimensions are the same as basic style.

CG1 Rod Side Flange Style

mm

Bore size (mm)	ZZ			
	1 to 50 st	51 to 100 st	101 to 125 st	126 to 200 st
20	131	156	181	—
25	136	161	186	211
32	138	163	188	213
40	155	180	205	230

CG1 Head Side Flange Style

mm

Bore size (mm)	ZZ			
	1 to 50 st	51 to 100 st	101 to 125 st	126 to 200 st
20	137	162	187	—
25	143	168	193	218
32	145	170	195	220
40	163	188	213	238

CG1 Trunnion Style

mm

Bore size (mm)	Stroke range (mm)	B	TDe8	TE	TF	TH	TR	TS	TT	TV	TW	TX	TY	TZ
20	Up to 125	38	8 ^{-0.025} _{-0.047}	10	5.5	25	39	28	3.2	(35.8)	42	16	28	47.6
25	Up to 200	45.5	10 ^{-0.025} _{-0.047}	10	5.5	30	43	33	3.2	(39.8)	42	20	28	53
32	Up to 200	54	12 ^{-0.032} _{-0.059}	10	6.6	35	54.5	40	4.5	(49.4)	48	22	28	67.7
40	Up to 200	63.5	14 ^{-0.032} _{-0.059}	10	6.6	40	65.5	49	4.5	(58.4)	56	30	30	78.7

* Consists of pin, flat washer and hexagon socket head cap bolt.

* Other dimensions are the same as basic style.

CG1 Rod Side Trunnion Style

mm

Bore size (mm)	Z	ZZ			
		1 to 50 st	51 to 100 st	101 to 125 st	126 to 200 st
20	46	131	156	181	—
25	51	136	161	186	211
32	51	138	163	188	213
40	62	155	180	205	230

CG1 Head Side Trunnion Style

mm

Bore size (mm)	1 to 50 st		51 to 100 st		101 to 125 st		126 to 200 st	
	Z	ZZ	Z	ZZ	Z	ZZ	Z	ZZ
20	118	139	143	164	168	189	—	—
25	123	144	148	169	173	194	198	219
32	126	150	151	175	176	200	201	225
40	143	171	168	196	193	221	218	246

CG1 Clevis Style

mm

Bore size (mm)	Stroke range (mm)	B	CD	CZ	L	RR	TE	TF	H	TT	TV
20	Up to 125	38	8	29	14	11	10	5.5	25	3.2	(35.8)
25	Up to 200	45.5	10	33	16	13	10	5.5	30	3.2	(39.8)
32	Up to 200	54	12	40	20	15	10	6.6	35	4.5	(49.4)
40	Up to 200	63.5	14	49	22	18	10	6.6	40	4.5	(58.4)

Bore size (mm)	TW	TX	TY	TZ	1 to 50 st		51 to 100 st		101 to 125 st		126 to 200 st	
					Z	ZZ	Z	ZZ	Z	ZZ	Z	ZZ
20	42	16	28	43.4	143	164	168	189	193	214	—	—
25	42	20	28	48	150	171	175	196	200	221	225	246
32	48	22	28	59.4	156	180	181	205	206	230	231	255
40	56	30	30	71.4	175	200	200	228	225	253	250	278

* For dimensions of pivot bracket, refer to Best Pneumatics.

* Other dimensions are the same as basic style.

Air Cylinder: Standard Type

Single Acting, Single Rod, Spring Return/Extend Series **NCG**

Rod side flange style: NCGFN/CG1FN

NCG Single Acting Rod Side Flange Mount Dimensions Inch

Bore Size (mm)	Stroke Range		B	E	F	FX	FD	FT	H
	Rod Side	Head Side							
20	Up to 5"	Up to 5"	1.57	0.472 $-0.0019/-0.0011$	0.08	1.10	0.22	0.24	1.00
25	Up to 8"	Up to 8"	1.73	0.551 $+0.0/-0.0011$	0.08	1.26	0.22	0.28	1.12
32	Up to 8"	Up to 8"	2.09	0.709 $+0.0/-0.0011$	0.08	1.50	0.28	0.28	1.63
40	Up to 8"	Up to 8"	2.40	0.984 $-0.0013/-0.0013$	0.08	1.81	0.28	0.31	1.63

* Other dimensions are the same as basic style

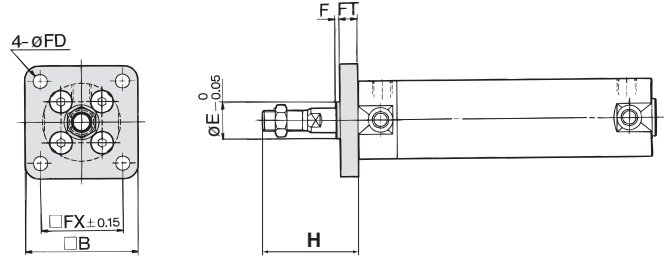

NCG Single Acting Head Side Flange Style Inch

Bore Size (mm)	ZZ			
	0" to 2.00" st	2.01" to 4.00" st	4.01" to 5.00" st	5.01" to 8.00" st
20	5.12	6.12	7.12	-
25	5.28	6.28	7.28	8.28
32	5.87	6.87	7.87	8.87
40	6.17	7.17	8.17	9.17

Head side flange style: NCGGN/CG1GN

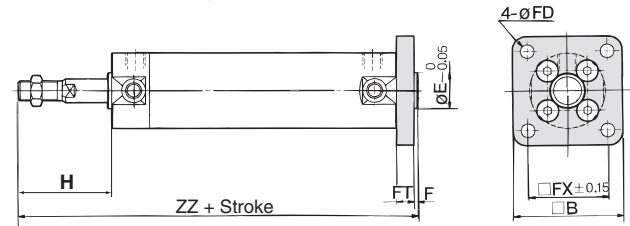

NCG Single Acting Trunnion Mount Dimensions Inch

Bore Size (mm)	Stroke Range		B	TDe8	TE	TF	TH	TR	TS	TT	TV	TW	TX	TY	TZ
	Rod Side	Head Side													
20	Up to 5"	Up to 5"	1.50	0.315 $-0.0009/-0.0019$	0.39	0.22	0.98	1.54	1.10	0.13	(1.41)	1.65	0.63	1.10	1.87
25	Up to 8"	Up to 8"	1.79	0.394 $-0.0009/-0.0019$	0.39	0.22	1.18	1.69	1.30	0.13	(1.57)	1.65	0.79	1.10	2.09
32	Up to 8"	Up to 8"	2.13	0.472 $-0.0013/-0.0023$	0.39	0.26	1.38	2.15	1.57	0.18	(1.94)	1.89	0.87	1.10	2.67
40	Up to 8"	Up to 8"	2.50	0.551 $-0.0013/-0.0023$	0.39	0.26	1.57	2.58	1.93	0.18	(2.30)	2.20	1.18	1.18	3.10

* Other dimensions are the same as basic style

Rod side trunnion style: NCGUN/CG1UN

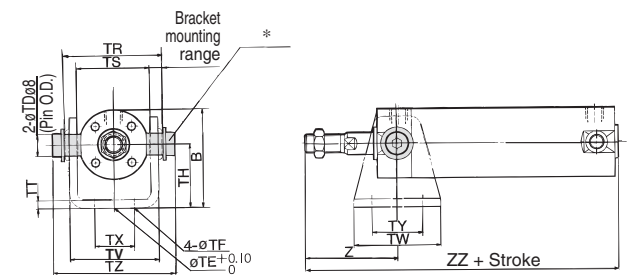

* Clevis pin and snap ring are shipped together.

NCG Single Acting Rod Side Trunnion Style Inch

Bore Size (mm)	Z	ZZ			
		0" to 2.00" st	2.01" to 4.00" st	4.01" to 5.00" st	5.01" to 8.00" st
20	1.43	4.80	5.80	6.80	-
25	1.55	4.92	5.92	6.92	7.92
32	2.06	5.51	6.51	7.51	8.51
40	2.10	5.78	6.78	7.78	8.78

NCG Single Acting Head Side Trunnion Style Inch

Bore Size (mm)	0" to 2.00" st		2.01" to 4.00" st		4.01" to 5.00" st		5.01" to 8.00" st	
	Z	ZZ	Z	ZZ	Z	ZZ	Z	ZZ
20	4.29	5.1	5.29	6.10	6.29	7.10	7.10	8.10
25	4.41	5.22	5.41	6.22	6.41	7.22	7.22	8.22
32	5.04	5.96	6.04	6.96	7.04	7.96	7.96	8.96
40	5.31	6.39	6.31	7.39	7.31	8.39	8.39	9.39

Head side trunnion style: NCGTN/CG1TN

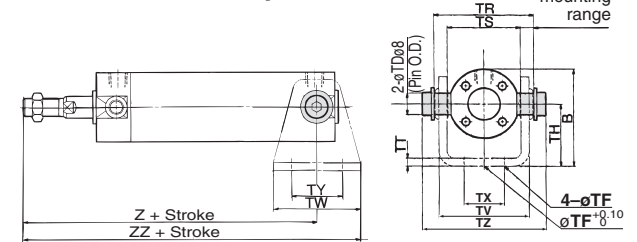

NCG Single Acting Double Clevis Mount Dimensions Inch

Bore Size (mm)	Stroke Range	B	CD	CX	CZ	J	L	RR	V	TE	TF	TH	TT	TV	TW	TX	TY	TZ
25	Up to 8"	1.79	0.39	-	1.30	#10-32UNF depth 0.30	0.63	0.51	-	0.39	0.22	1.18	0.13	1.57	1.65	0.79	1.10	1.89
32	Up to 8"	2.13	0.47	-	1.57	#10-32UNF depth 0.30	0.79	0.59	-	0.39	0.26	1.38	0.18	1.94	1.89	0.87	1.10	2.34
40	Up to 8"	2.50	0.55	-	1.93	1/4-28UNF depth 0.47	0.87	0.71	-	0.39	0.26	1.57	0.18	2.30	2.20	1.18	1.18	2.81

Bore Size (mm)	0" to 2.00" st		2.01" to 4.00" st		4.01" to 5.00" st		5.01" to 8.00" st	
	Z	ZZ	Z	ZZ	Z	ZZ	Z	ZZ
20	5.35	6.08	6.35	7.08	7.35	-	-	-
25	5.55	6.28	6.55	7.28	7.55	8.11	8.55	9.28
32	6.30	7.14	7.30	8.14	8.30	8.94	9.30	10.14
40	6.65	7.66	7.65	8.66	8.65	8.70	9.65	10.66

* Other dimensions are the same as basic style

Clevis style: NCGDN/CG1DN

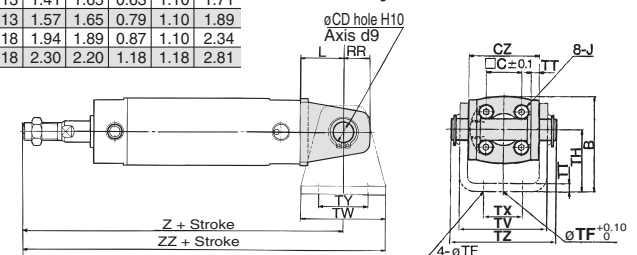

(The above shows the case port location is changed by 90°.)

Series NCG

Basic Style with Single Clevis: NCGC

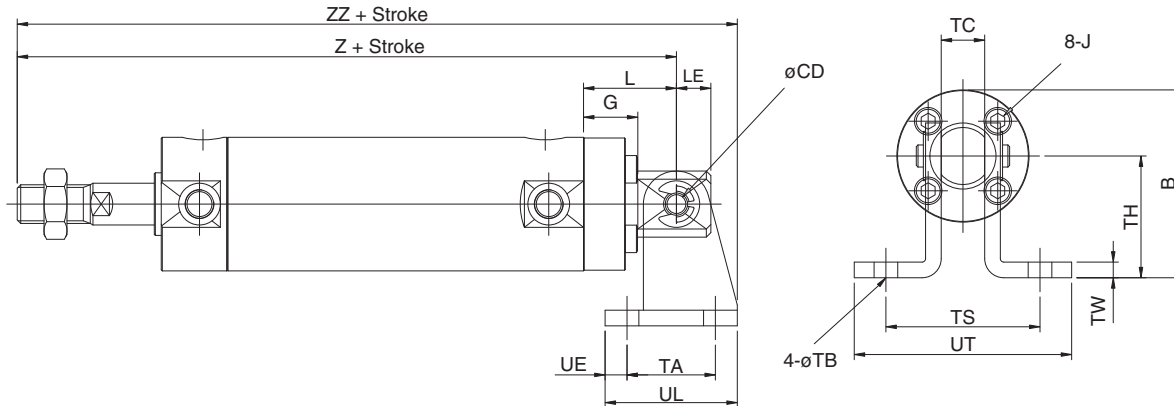

NCG Single Acting Single Clevis Mount Dimensions

Inch

Bore Size (mm)	Stroke Range	B	CD	G	J	L	LE	TA	TB	TC	TH	TS	TW	UE	UL	UT
20	Up to 5"	1.39	0.250	0.31	#8-32UNC depth 0.28	0.70	0.28	0.75	0.27	0.38	0.88	1.25	0.12	0.18	1.10	2.00
25	Up to 8"	1.49	0.250	0.33	#10-32UNF depth 0.30	0.68	0.28	0.75	0.27	0.38	0.88	1.25	0.12	0.18	1.10	2.00
32	Up to 8"	1.63	0.250	0.61	#10-32UNF depth 0.30	1.07	0.39	0.75	0.27	0.50	0.88	1.38	0.12	0.18	1.10	2.12
40	Up to 8"	2.31	0.375	0.39	1/4-28UNF depth 0.47	0.88	0.38	1.00	0.27	0.62	1.38	1.86	0.18	0.25	1.50	2.62

Bore Size (mm)	0" to 2.00" st		2.01" to 4.00" st		4.01" to 5.00" st		5.01" to 8.00" st	
	Z	ZZ	Z	ZZ	Z	ZZ	Z	ZZ
20	5.50	6.08	6.50	7.08	7.50	8.08	-	-
25	5.60	6.28	6.60	7.28	7.60	8.28	8.60	9.28
32	6.58	7.14	7.58	8.14	8.58	9.14	9.58	10.14
40	6.66	7.66	7.66	8.66	8.66	9.66	9.66	10.66

* Other dimensions are the same as basic style

Basic Style with Front Nose: NCGN

20mm and 25mm Bores

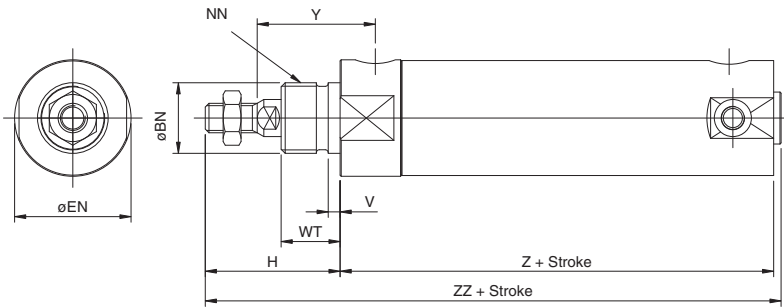

32mm Through 40mm Bores

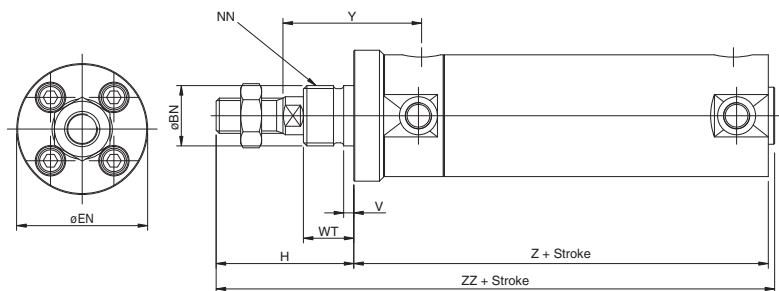

NCG Single Acting Front Nose Mount Dimensions

Inch

Bore Size (mm)	Stroke Range	BN	EN	H	NN	V	WT	Y	0" to 2.00" st		2.01" to 4.00" st		4.01" to 5.00" st		5.01" to 8.00" st		
									Z	ZZ	Z	ZZ	Z	ZZ	Z	ZZ	
20	Up to 8	0.749	+0.0002/-0.003	1.12	1.43	3/4-16UNF	0.12	0.63	1.25	3.60	5.11	4.60	6.11	5.60	7.11	-	-
25	Up to 12	0.749	+0.0002/-0.003	1.24	1.43	3/4-16UNF	0.12	0.63	1.25	3.60	5.11	4.60	6.11	5.60	7.11	6.60	8.11
32	Up to 12	0.749	+0.0002/-0.003	1.63	1.71	3/4-16UNF	0.12	0.63	1.75	4.15	5.94	5.15	6.94	6.15	7.94	7.15	8.94
40	Up to 12	1.058	+0.0002/-0.003	2.00	2.00	1-14UNF	0.19	0.88	2.32	4.62	6.70	5.62	7.70	6.62	8.70	7.62	9.70

Note): * Other dimensions are the same as basic style

Air Cylinder: Standard Type Single Acting, Single Rod, Spring Return/Extend Series **NCG/GC1**

Operating Range

Auto switch model	Bore size (mm)			
	20	25	32	40
D-C7□/C80 D-C73C/C80C D-B5□/B64	8	10	9	10
D-B59W	13	13	14	14
D-M9, D-M9A D-M9W	4	4	4.5	5
D-H7C	7	8.5	9	10
D-H7NF	5	5	5.5	6
D-G5NTL	4	4	4.5	5
D-G5NBL	35	40	40	45

Other than the applicable auto switches listed in "How to Order", the following auto switches can be mounted. For detailed specifications, refer to Best Pneumatics.

Type	Model	Electrical entry	Features	Applicable bore size (mm)
Reed switch	D-C80	Grommet	Without indicator light	20 to 40
	D-C80C	Connector		
	D-B53	Grommet	—	
	D-B64		Without indicator light	

* Timer equipped type, solid state auto switch (D-G5NTL) is also available.
 * Wide range detection type, solid state auto switch (D-G5NBL) is also available.
 * With pre-wire connector is available for D-G5NTL and D-G5NBL.

* Since this is a guideline including hysteresis, not meant to be guaranteed.
 (Assuming approximately ±30% dispersion)
 There may be the case it will vary substantially depending on an ambient environment.

Proper Auto Switch Mounting Position (Detection at stroke end) and Its Mounting Height

D-C7, D-C8

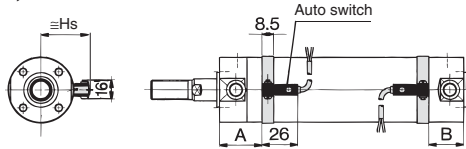

D-H7□, D-H7□W
D-H7NF, D-H7BAL

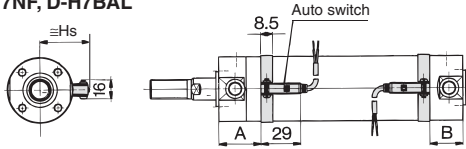

(): Denotes the values of D-H7LF.

D-B5, D-B6, D-B59W

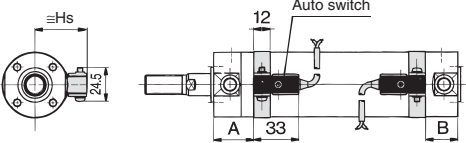

D-G5NTL

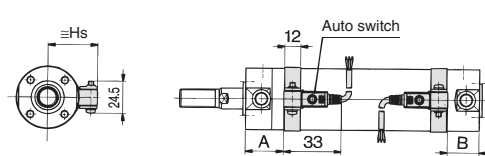

D-C73C, D-C80C

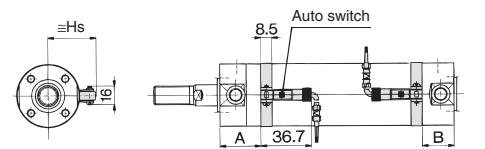

D-H7C

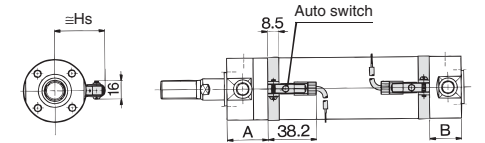

Single Acting, Spring Return

Auto switch model	Bore size (mm)	A							B	Hs
		25	50	75	100	125	150	200		
D-C7 D-C8 D-C73C D-C80C	20	55	55	80	80	105	—	—	20.5	24.5(27)
	25	55	55	80	80	105	130	130	20.5	27(29.5)
	32	56	56	81	81	106	131	131	21.5	30.5(33)
	40	60.5	60.5	85.5	85.5	110.5	135.5	135.5	23.5	35(37.5)
D-M9 D-M9A D-M9W	20	54	54	79	79	104	—	—	19.5	24.5(27.5)
	25	54	54	79	79	104	129	129	19.5	27(30)
	32	55	55	80	80	105	130	130	20.5	30.5(33.5)
	40	59.5	59.5	84.5	84.5	109.5	134.5	134.5	22.5	35(38)
D-B5 D-B6	20	49	49	74	74	99	—	—	15.5	27.5
	25	49	49	74	74	99	124	124	15.5	30
	32	50	50	75	75	100	125	125	15.5	33.5
	40	54.5	54.5	79.5	79.5	104.5	129.5	129.5	19	38
D-G5NTL D-G59F	20	50.5	50.5	75.5	75.5	100.5	—	—	16	27.5
	25	50.5	50.5	75.5	75.5	100.5	125.5	125.5	16	30
	32	51.5	51.5	76.5	76.5	101.5	126.5	126.5	17	33.5
	40	56	56	81	81	106	131	131	19	38
D-B59W	20	52	52	77	77	102	—	—	17.5	27.5
	25	52	52	77	77	102	127	127	17.5	30
	32	53	53	78	78	103	128	128	18.5	33.5
	40	57.5	57.5	82.5	82.5	107.5	132.5	132.5	20.5	38

(): Denotes the dimensions with connector.

Single Acting, Spring Extend

Auto switch model	Bore size (mm)	A	B							Hs
			All stroke	25	50	75	100	125	150	
D-C7 D-C8 D-C73C D-C80C	20	30	45.5	45.5	70.5	70.5	95.5	—	—	24.5(27)
	25	30	45.5	45.5	70.5	70.5	95.5	120.5	120.5	27(29.5)
	32	31	46.5	46.5	71.5	71.5	96.5	121.5	121.5	30.5(33)
	40	35.5	48.5	48.5	73.5	73.5	98.5	123.5	123.5	35(37.5)
D-M9 D-M9A D-M9W	20	29	44.5	44.5	69.5	69.5	94.5	—	—	24.5(27.5)
	25	29	44.5	44.5	69.5	69.5	94.5	119.5	119.5	27(30)
	32	30	45.5	45.5	70.5	70.5	95.5	120.5	120.5	30.5(33.5)
	40	34.5	47.5	47.5	72.5	72.5	97.5	122.5	122.5	35(38)
D-B5 D-B6	20	24	39.5	39.5	64.5	64.5	89.5	—	—	27.5
	25	24	39.5	39.5	64.5	64.5	89.5	114.5	114.5	30
	32	25	40.5	40.5	65.5	65.5	90.5	115.5	115.5	33.5
	40	29.5	42.5	42.5	67.5	67.5	92.5	117.5	117.5	38
D-G5NTL D-G59F	20	25.5	41	41	66	66	91	—	—	27.5
	25	25.5	41	41	66	66	91	116	116	30
	32	26.5	42	42	67	67	92	117	117	33.5
	40	31	44	44	69	69	94	119	119	38
D-B59W	20	27	42.5	42.5	67.5	67.5	92.5	—	—	27.5
	25	27	42.5	42.5	67.5	67.5	92.5	117.5	117.5	30
	32	28	43.5	43.5	68.5	68.5	93.5	118.5	118.5	33.5
	40	32.5	45.5	45.5	70.5	70.5	95.5	120	120.5	38

(): Denotes the dimensions with connector.

Series NCGK/CG1K

ø20, ø25, ø32, ø40, ø50, ø63

How to Order

Without auto switch
NCGK

With auto switch
NCDGK

Mounting style

B	Basic style
C	Single clevis
L	Axial foot style
F	Front flange style
G	Rear flange style

Urethane cushion

U	Front trunnion style
T	Rear trunnion style
D	Double Clevis style

Urethane cushion

N	Urethane cushion
---	------------------

Bore size

20	20 mm (3/4")	40	40 mm (1-1/2")
25	25 mm (1")	50	50 mm (2")
32	32 mm (1-1/4")	63	63 mm (2-1/2")

Number of auto switches

Nil	2 pcs.
S	1 pc.
n	"n" pcs.

Auto switch

Nil	Without auto switch (Built-in magnet)
-----	---------------------------------------

Stroke Hundredths of an inch*

*Stroke length must be indicated as 4 digits. First and second digit: Stroke/Inch Third and fourth digit: Stroke/Hundredth of an inch Example) 0525=5.25 (5-1/4) inch stroke

How to Order

Without auto switch
CG1K

With auto switch
CDG1K

Mounting style

B	Basic style
L	Axial foot style
F	Rod side flange style
G	Head side flange style
U	Rod side trunnion style
T	Head side trunnion style
D	Clevis style

Bore size

20	20 mm
25	25 mm
32	32 mm
40	40 mm
50	50 mm
63	63 mm

Cushion

N	Urethane cushion
A	Non-lube/Air cushion (ø40 to ø63 only)

Number of auto switches

Nil	2 pcs.
S	1 pc.
n	"n" pcs.

Auto switch

Nil	Without auto switch (Built-in magnet)
-----	---------------------------------------

*For the applicable auto switch model, refer to the table below.

Cylinder stroke (mm)

Refer to "Standard Stroke" on Best Pneumatics .

Note) Mounting brackets are shipped together, (but not assembled).

Applicable Auto Switch/Refer to Best Pneumatics for further information on auto switches.

Type	Special function	Electrical entry	Indicator light	Wiring (Output)	Load voltage		Auto switch model		Lead wire length (m)*				Pre-wire connector	Applicable load		
					DC	AC	Applicable bore size (mm)		0.5 (Nil)	3 (L)	5 (Z)	None (N)				
Reed switch	—	Grommet	Yes	3-wire (NPN equivalent)	—	5 V	—	C76	—	●	●	—	—	—	IC circuit	—
				2-wire	24 V	12 V	100 V, 200 V	B54		●	●	●	—	—	—	—
	100 V	C73	—				●	●	●	●	—	—				
Diagnostic indication (2-color indication)	Grommet	—	—	—	—	—	B59W		●	●	—	—	—	—	—	
Solid state switch	—	Grommet	Yes	3-wire (NPN)	24 V	5 V, 12 V	—	M9N	G59	●	—	○	—	○	IC circuit	Relay, PLC
				3-wire (PNP)				M9P	G5P	●	—	○	—	○		
	2-wire			M9B				K59	●	—	○	—	○			
	3-wire (NPN)			M9NW				G59W	●	●	○	—	○			
	3-wire (PNP)			M9PW				G5PW	●	●	○	—	○			
	2-wire			M9BW				K59W	●	●	○	—	○			
	Water resistant (2-color indication)			M9BA				G5BA	●	●	○	—	○			
Diagnostic output (2-color indication)	—	G59F	●	●	○	—	○	IC circuit								

* Lead wire length symbols: 0.5 m Nil (Example) C73C M9NW
 3 m L (Example) C73CL M9NL
 5 m Z (Example) C73CZ M9NZ
 None N (Example) C73CN

* Solid state switches marked with "○" are produced upon receipt of order.

- Since there are other applicable auto switches than listed, contact SMC for details.
- For details about auto switches with pre-wire connector, refer to Best Pneumatics.

Non-rotating accuracy

ø20, ø25..... ±1°
ø32..... ±0.8°
ø40 to ø63..... ±0.5°

High speed operation/Long service life

Piston speed is between 50 and 500 mm/s and long service life is expected.

Can operate without lubrication.

The same installation dimensions as the standard cylinder.

Auto switches can also be mounted.

It can be installed with auto switches to simplify the detection of the stroke position of the cylinder.

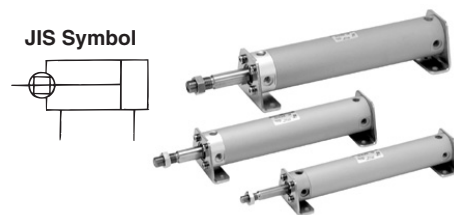

Standard Stroke (for CG1K)

Bore size (mm)	Standard stroke ⁽¹⁾ (mm)	Long stroke (mm)	Maximum manufacturable stroke (mm)
20	25, 50, 75, 100, 125, 150, 200	201 to 350	1500
25	25, 50, 75, 100, 125, 150, 200, 250, 300	301 to 400	
32		301 to 450	
40		301 to 800	
50, 63		301 to 1200	

Note1) Other intermediate strokes can be manufactured upon receipt of an order. Spaces are not used for the intermediate strokes.

Note2) Long stroke applies to the axial foot style and the rod side flange style. If other length exceeds the stroke limit, the stroke should be determined based on the stroke selection table in the technical data.

Standard Stroke (for NCG)

Bore size (mm)	Standard stroke ⁽¹⁾ (inch)	Long stroke (inch)	Maximum manufacturable stroke (inch)
20	1, 2, 3, 4, 5, 6, 8	20	76
25	1, 2, 3, 4, 5, 6, 8, 10, 12	25	
32		40	
40		45	
50		55	
63	55		

Note1) Other intermediate strokes can be manufactured upon receipt of an order. Spaces are not used for the intermediate strokes.

Note2) Long stroke applies to the axial foot style and the rod side flange style. If other length exceeds the stroke limit, the stroke should be determined based on the stroke selection table in the technical data.

Specifications

Bore size (mm)	20	25	32	40	50	63
Action	Double acting, Single rod					
Type	Non-lube					
Fluid	Air					
Proof pressure	1.5 MPa					
Maximum operating pressure	1.0 MPa					
Minimum operating pressure	0.05 MPa					
Ambient and fluid temperature	Without auto switch: -10 to 70°C (No freezing) With auto switch: -10 to 60°C (No freezing)					
Piston speed	50 to 500 mm/s					
Thread tolerance	JIS Class 2					
Stroke length tolerance	Up to 600 ^{±1.4} mm					
Cushion	Rubber bumper, Air cushion (ø40 to ø63 only)					
Rod non-rotating accuracy	±1°	±0.8°	±0.5°			
Mounting	Basic style, Axial foot style, Rod side flange style, Head side flange style, Rod side trunnion style, Head side trunnion style, Clevis style (Used for changing the port location by 90°.)					

Accessory

Mounting		Basic style	Axial foot style	Rod side flange style	Head side flange style	Rod side trunnion style	Head side trunnion style	Clevis style
Standard equipment	Rod end nut	●	●	●	●	●	●	●
	Clevis pin	—	—	—	—	—	—	●
Option	Single knuckle joint	●	●	●	●	●	●	●
	Double knuckle joint * (With pin)	●	●	●	●	●	●	●
	Pivot bracket	—	—	—	—	●	●	●

* Pin and snap ring are shipped together with double knuckle joint.

With Auto Switch

Double acting: Auto switch can be mounted for non-rotating rod. Mounting position is the same as double acting, single rod type. Refer to Best Pneumatics.

Other than the applicable auto switches listed in "How to Order", the following auto switches can be mounted. For detailed specifications, refer to Best Pneumatics.

Type	Model	Electrical entry	Features	Applicable bore size (mm)
Reed switch	D-C80	Grommet	Without indicator light	20 to 63
	D-C80C	Connector		
	D-B53	Grommet	—	
	D-B64		Without indicator light	

* Timer equipped type, solid state auto switch (D-G5NTL) is also available.
* Wide range detection type, solid state auto switch (D-G5NBL) is also available.
* With pre-wire connector is available for D-G5NTL and D-G5NBL.

Made to Order Specifications (For details, refer to Best Pneumatics.)

Symbol	Specifications	NCG	CG1
-XA□	Change of rod end shape	●	●
-XC8	Adjustable stroke cylinder/Adjustable extension type	●	●
-XC9	Adjustable stroke cylinder/Adjustable retraction type	●	●
-XC10	Dual stroke cylinder/Double rod type	●	●
-XC11	Dual stroke cylinder/Single rod type	●	●
-XC12	Tandem type cylinder	●	●
-XC13	Auto switch rail mounting style	●	●
-XC20	Head cover axial port	●	●

Series NCGK/CG1K

Weight

(kg)

Bore size (mm)		20	25	32	40	50	63
Basic weight	Basic style	0.10	0.17	0.26	0.41	0.77	1.07
	Axial foot style	0.21	0.30	0.42	0.63	1.25	1.79
	Flange style	0.18	0.27	0.40	0.61	1.11	1.57
	Trunnion style	0.11	0.19	0.29	0.46	0.91	1.21
	Clevis style	0.15	0.25	0.41	0.64	1.17	1.75
Pivot bracket		0.08	0.09	0.17	0.25	0.44	0.80
Single knuckle joint		0.05	0.09	0.09	0.10	0.22	0.22
Double knuckle joint (With pin)		0.05	0.09	0.09	0.13	0.26	0.26
Additional weight per each 50 mm of stroke		0.05	0.07	0.09	0.15	0.22	0.26
Additional weight with air cushion		—	—	—	0.02	0.03	0.03
Additional weight for long stroke		—	—	—	0.03	0.06	0.10

Calculation: (Example) CG1KLN20-100
 • Basic weight.....0.21 (Foot, ø20)
 • Additional weight.....0.05/50st
 • Cylinder stroke.....100st
 $0.21 + 0.05 \times 100/50 = 0.31 \text{ kg}$

Auto Switch Mounting Bracket Part No.

Auto switch model	Bore size (mm)					
	20	25	32	40	50	63
D-C7/C8	BMA2-020	BMA2-025	BMA2-032	BMA2-040	BMA2-050	BMA2-063
D-B5/B6	BA-01	BA-02	BA-32	BA-04	BA-05	BA-06
D-G5/K5						
D-M9	BMA2-020	BMA2-025	BMA2-032	BMA2-040	BMA2-050	BMA2-063
BJ3-1 (Adaptor piece)						



* Mounting screws set made of stainless steel
 The following set of mounting screws made of stainless steel is also available. Use it in accordance with the operating environment.
 (A switch mounting band is not included, so please order it separately.)

Mounting Bracket Part No.

Mounting bracket	Bore size (mm)					
	20	25	32	40	50	63
Axial foot *	CG-L020	CG-L025	CG-L032	CG-L040	CG-L050	CG-L063
Flange	CG-F020	CG-F025	CG-F032	CG-F040	CG-F050	CG-F063
Trunnion pin	CG-T020	CG-T025	CG-T032	CG-T040	CG-T050	CG-T063
Clevis **	CG-D020	CG-D025	CG-D032	CG-D040	CG-D050	CG-D063
Pivot bracket	CG-020-24A	CG-025-24A	CG-032-24A	CG-040-24A	CG-050-24A	CG-063-24A



* Order two foot brackets per cylinder.
 **Mounting bolt is shipped together with foot style and flange style, and clevis pin, snap ring and mounting bolt for clevis style.

NCGK Mounting Bracket Part No.

Mounting Bracket	Bore size (mm)					
	20	25	32	40	50	63
Foot	NCG-L020	NCG-L025	NCG-L032	NCG-L040	NCG-L050	NCG-L063
Flange	NCG-F020	NCG-F025	NCG-F032	NCG-F040	NCG-F050	NCG-F063
Trunnion	NCG-T020	CG-T025	CG-T032	NCG-T040	NCG-T050	NCG-T063
Trunnion Bracket	NCG-P020	NCG-P025	NCG-P032	NCG-P040	NCG-P050	NCG-P063
Double Clevis	NCG-D020	NCG-D025	NCG-D032	NCG-D040	NCG-D050	NCG-D063
Single Clevis	NCG-C020	NCG-C025	NCG-C032	NCG-C040	NCG-C050	NCG-C063

Copper-free

20-CG1K Mounting style N Bore size Stroke

Copper-free

The type which prevents copper based ions from generating by changing the copper based materials into electroless nickel plated treatment or non-copper materials in order to eliminate the effects by copper based ions or fluororesins over the color cathode ray tube.

Specifications

Bore size (mm)	20, 25, 32, 40, 50, 63
Action	Double acting
Fluid	Air
Maximum operating pressure	1.0 MPa
Minimum operating pressure	0.05 MPa
Piston speed	50 to 500 mm/s
Mounting	Basic style, Axial foot style, Rod side flange style, Head side flange style, Rod side trunnion style, Head side trunnion style, Clevis style (Used for changing the port location by 90°.)

Basic Style NCGK/CG1K

With rubber bumper: CG1KBN
ø20 to ø63

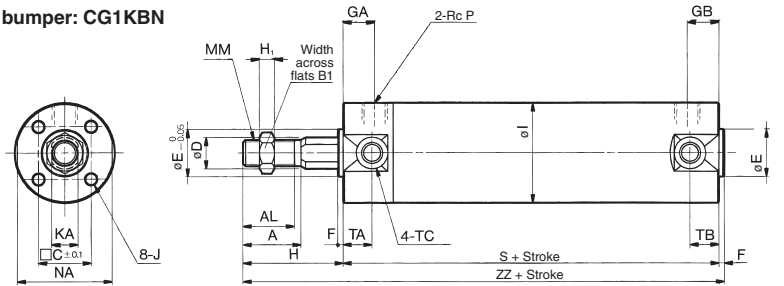

With air cushion: CG1KBA
ø40 to ø63

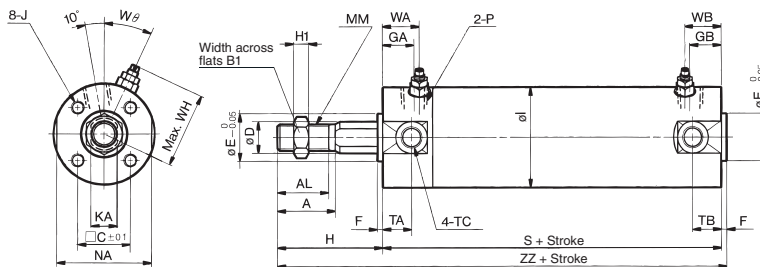

With Air Cushion

Bore size (mm)	P	WA	WB	WH	Wø
40	Rc 1/8	16	15(16)	33	20°
50	Rc 1/4	18	17(18)	40.5	20°
63	Rc 1/4	18	17(18)	47.5	20°

Note) (): Denotes the dimensions for long stroke.

CGIK Basic Style

Bore size (mm)	Stroke range (mm)	A	AL	B1	C	D	E	F	GA	GB	H	H1	I	J	KA	MM	NA	P	S	TA	TB	TC	ZZ
20	Up to 200	18	15.5	13	14	9.2	12	2	12	10	35	5	26	M4 x 0.7 depth 7	8	M8 x 1.25	24	1/8	69	11	11	M5 x 0.8	106
25	Up to 300	22	19.5	17	16.5	11	14	2	12	10	40	6	31	M5 x 0.8 depth 7.5	10	M10 x 1.25	29	1/8	69	11	11	M6 x 0.75	111
32	Up to 300	22	19.5	17	20	12	18	2	12	10	40	6	38	M5 x 0.8 depth 8	10	M10 x 1.25	35.5	1/8	71	11	10	M8 x 1.0	113
40	Up to 300(500)	30	27	19	26	16	25	2	13	10(13)	50	8	47	M6 x 1 depth 12	14	M14 x 1.5	44	1/8	78(87)	12	10(12)	M10 x 1.25	130(139)
50	Up to 300(600)	35	32	27	32	20	30	2	14	12(14)	58	11	58	M8 x 1.25 depth 16	18	M18 x 1.5	55	1/4	90(102)	13	12(13)	M12 x 1.25	150(162)
63	Up to 300(600)	35	32	27	38	20	32	2	14	12(14)	58	11	72	M10 x 1.5 depth 16	18	M18 x 1.5	69	1/4	90(102)	13	12(13)	M14 x 1.5	150(162)

Note 1) Dimensions for each mounting bracket are the same as those for CG1 standard or long stroke model. Refer to Best Pneumatics. Also, as for the one with auto switch, it is the same as standard products of Series CDG1.

Note 2) (): Long stroke

NCGK Basic Mount Dimensions (Inches)

Bore Size (mm)	Standard stroke range (inch)	A	AL	B1	C+/-0.004	D	E+0/-0.002	F	GA	GB	H	H1	I	J	K	KA	MM	NA	P (NPT)
20	Up to 8	0.50	0.55	0.44	0.55	0.315	0.472	0.08	0.47	0.39	1.00	0.16	1.02	#8-32UNC depth 0.28	0.16	0.24	1/4-28UNF	0.94	1/8
25	Up to 12	0.50	0.55	0.50	0.65	0.394	0.551	0.08	0.47	0.39	1.12	0.19	1.22	#10-32UNF depth 0.30	0.20	0.31	5/16-24UNF	1.14	1/8
32	Up to 12	0.75	0.83	0.69	0.79	0.472	0.709	0.08	0.47	0.39	1.63	0.26	1.50	#10-32UNF depth 0.30	0.22	0.39	7/16-20UNF	1.40	1/8
40	Up to 12 (20)	0.75	-	0.69	1.02	0.630	0.984	0.08	0.51	0.39 (0.51)	1.63	0.26	1.85	1/4-28UNF depth 0.47	0.30	0.55	7/16-20UNF	1.73	1/8
50	Up to 12 (24)	0.88	-	0.75	1.26	0.787	1.181	0.08	0.55	0.47 (0.55)	2.07	0.32	2.28	5/16-24UNF depth 0.63	0.30	0.71	1/2-20UNF	2.17	1/4
63	Up to 12 (24)	0.88	-	0.75	1.50	0.787	1.260	0.08	0.55	0.47 (0.55)	2.07	0.32	2.83	3/8-24UNF depth 0.63	0.30	0.71	1/2-20UNF	2.72	1/4

Note) (): Denotes the dimensions for long stroke

Refer to Model Selection Charts in Best Pneumatics for acceptable loading for long stroke cylinders

⚠ Precautions

Be sure to read before handling. For Safety Instructions and Actuator Precautions, refer to Best Pneumatics.

Caution on Handling/Disassembly

⚠ Caution

1. Avoid using the air cylinder in such a way that rotational torque would be applied to the piston rod.

- If rotational torque is applied, the non-rotating guide will become deformed, thus affecting the non-rotating accuracy. Refer to the table below for the approximate values of the allowable range of rotational torque.

Allowable rotational torque (N·m or less)	ø20	ø25, ø32	ø40, ø50, ø63
	0.2	0.25	0.44

- To screw a bracket or a nut onto the piston rod, make sure to retract the piston rod entirely, and place a wrench over the flat portion of the rod that protrudes.

Tighten it by giving consideration to prevent the tightening torque from being applied to the non-rotating guide.

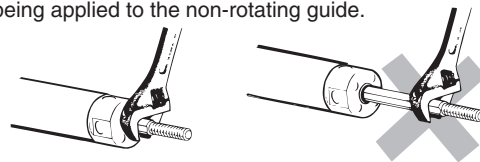

2. When replacing rod seals, please contact SMC.

Air leakage may be happened, depending on the position in which a rod seal is fitted. Thus, please contact SMC when replacing them.

Air Cylinder: Non-rotating Rod Type Double Acting, Double Rod

Series **CG1KW**

ø20, ø25, ø32, ø40, ø50, ø63



How to Order

Without auto switch

CG1KW L N 25-100

With auto switch

CDG1KW L N 25-100-M9NW

Built-in magnet

Non-rotating rod type

Double acting, double rod type

Mounting style

B	Basic style
L	Axial foot style
F	Rod side flange style
U	Rod side trunnion style

Note) Mounting brackets are shipped together, (but not assembled).

Bore size

20	20 mm
25	25 mm
32	32 mm
40	40 mm
50	50 mm
63	63 mm

Cushion

N	Non-lube/Rubber bumper
----------	------------------------

Number of auto switches

Nil	2 pcs.
S	1 pc.
n	"n" pcs.

Auto switch

Nil	Without auto switch (Built-in magnet)
------------	---------------------------------------

*For the applicable auto switch model, refer to the table below.

Cylinder stroke (mm)

Applicable Auto Switch/Refer to Best Pneumatics for further information on auto switches.

Type	Special function	Electrical entry	Indicator light	Wiring (Output)	Load voltage		Auto switch model		Lead wire length (m) *				Pre-wire connector	Applicable load		
					DC	AC	Applicable bore size (mm)		0.5 (Nil)	3 (L)	5 (Z)	None (N)		IC circuit	Relay, PLC	
							20 to 63	80, 100								
Reed switch	—	Grommet	Yes	3-wire (NPN equivalent)	—	5 V	—	C76	—	●	●	—	—	—	—	IC circuit
				2-wire	24 V	12 V	100 V, 200 V	B54	—	●	●	●	—	—	—	Relay, PLC
	Connector	Grommet	2-wire	—	—	—	C73	—	●	●	●	—	—	—		
	Diagnostic indication (2-color indication)			—	—	—	C73C	—	●	●	●	●	—		—	
Solid state switch	—	Grommet	Yes	3-wire (NPN)	24 V	5 V, 12 V	—	M9N	G59	●	—	○	—	○	IC circuit	Relay, PLC
				3-wire (PNP)				M9P	G5P	●	—	○	—	○		
	Diagnostic indication (2-color indication)	Grommet	Yes	2-wire	24 V	5 V, 12 V	—	M9B	K59	●	—	○	—	○	IC circuit	Relay, PLC
				3-wire (NPN)				M9NW	G59W	●	●	○	—	○		
				3-wire (PNP)				M9PW	G5PW	●	●	○	—	○		
				2-wire				M9BW	K59W	●	●	○	—	○		
	Water resistant (2-color indication)	Grommet	Yes	2-wire	24 V	5 V, 12 V	—	M9BA	G5BA	●	●	○	—	○	—	Relay, PLC
	4-wire (NPN)			—				G59F	●	●	○	—	○			
Diagnostic output (2-color indication)	—	—	—	—	—	—	—	G59F	—	●	●	○	—	○	IC circuit	

* Lead wire length symbols: 0.5 m Nil (Example) C73C M9NW
 3 m L (Example) C73CL M9NL
 5 m Z (Example) C73CZ M9NZ
 None N (Example) C73CN

* Solid state switches marked with "○" are produced upon receipt of order.

- Since there are other applicable auto switches than listed, contact SMC for details.
- For details about auto switches with pre-wire connector, refer to Best Pneumatics.

Non-rotating accuracy

$\varnothing 20, \varnothing 25 \dots \pm 1^\circ$
 $\varnothing 32 \dots \pm 0.8^\circ$
 $\varnothing 40 \text{ to } \varnothing 63 \dots \pm 0.5^\circ$

High speed operation/Long service life

Piston speed is between 50 and 500 mm/s and long service life is expected.

Can operate without lubrication. The same installation dimensions as the standard cylinder. Auto switches can also be mounted.

It can be installed with auto switches to simplify the detection of the stroke position of the cylinder.



JIS Symbol

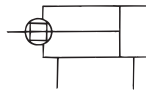

Specifications

Bore size (mm)	20	25	32	40	50	63
Action	Double acting, Double rod					
Type	Non-lube					
Fluid	Air					
Proof pressure	1.5 MPa					
Maximum operating pressure	1.0 MPa					
Minimum operating pressure	0.08 MPa					
Ambient and fluid temperature	Without auto switch: -10 to 70°C (No freezing) With auto switch: -10 to 60°C (No freezing)					
Piston speed	50 to 500 mm/s					
Thread tolerance	JIS Class 2					
Stroke length tolerance	Up to $600^{+1.4}_0$ mm					
Cushion	Rubber bumper					
Rod non-rotating accuracy	$\pm 1^\circ$	$\pm 0.8^\circ$	$\pm 0.8^\circ$	$\pm 0.5^\circ$	$\pm 0.5^\circ$	$\pm 0.5^\circ$
Mounting	Basic style, Axial foot style, Rod side flange style, Rod side trunnion style					

Accessory

Mounting		Basic style	Axial foot style	Rod side flange style	Rod side trunnion style
Standard equipment	Rod end nut	●	●	●	●
Option	Single knuckle joint	●	●	●	●
	Double knuckle joint (With pin) **	●	●	●	●
	Pivot bracket	—	—	—	●*

* Pin and snap ring are shipped together with double knuckle joint.

Standard Stroke

Bore size (mm)	Standard stroke (mm) ⁽¹⁾	Long stroke (mm)
20	25, 50, 75, 100, 125, 150, 200	—
25	25, 50, 75, 100, 125, 150, 200, 250, 300	—
32		—
40		301 to 500
50, 63		301 to 600

Note1) Intermediate strokes other than the above are produced upon receipt of order. Spacers are not used for intermediate strokes.

Note2) The maximum limit is 1500 stroke, but the products that exceed the standard or long stroke limit are not guaranteed.

Series CG1KW

Weight

Bore size (mm)		20	25	32	40	50	63
Basic weight	Basic style	0.13	0.22	0.33	0.55	1.02	1.37
	Axial foot style	0.24	0.35	0.49	0.77	1.50	2.09
	Flange style	0.21	0.32	0.47	0.75	1.36	1.87
	Trunnion style	0.14	0.24	0.36	0.60	1.16	1.51
Pivot bracket		0.08	0.09	0.17	0.25	0.44	0.80
Single knuckle joint		0.05	0.09	0.09	0.10	0.22	0.22
Double knuckle joint (With pin)		0.05	0.09	0.09	0.13	0.26	0.26
Additional weight per each 50 mm of stroke		0.07	0.10	0.13	0.23	0.34	0.38

Calculation: (Example) CG1KWLN32-100 (Foot style, ø32, 100 st)

- Basic weight.....0.49 (Foot, ø32) • Cylinder stroke.....100 st
- Additional weight.....0.13/50 st 0.49 + 0.13 x 100/50 = 0.75 kg

Mounting Bracket Part No.

Mounting bracket	Bore size (mm)					
	20	25	32	40	50	63
Axial foot *	CG-L020	CG-L025	CG-L032	CG-L040	CG-L050	CG-L063
Flange	CG-F020	CG-F025	CG-F032	CG-F040	CG-F050	CG-F063
Trunnion pin	CG-T020	CG-T025	CG-T032	CG-T040	CG-T050	CG-T063
Pivot bracket	CG-020 -24A	CG-025 -24A	CG-032 -24A	CG-040 -24A	CG-050 -24A	CG-063 -24A

* Order two foot brackets per a cylinder.

** Mounting bolts are shipped together for foot style and flange style.

Auto Switch Mounting Bracket Part No.

Auto switch model	Bore size (mm)					
	20	25	32	40	50	63
D-C7/C8	BMA2-020	BMA2-025	BMA2-032	BMA2-040	BMA2-050	BMA2-063
D-B5/B6	BA-01	BA-02	BA-32	BA-04	BA-05	BA-06
D-G5/K5						
D-M9	BMA2-020	BMA2-025	BMA2-032	BMA2-040	BMA2-050	BMA2-063
BJ3-1 (Adaptor piece)						



* Mounting screws set made of stainless steel

The following set of mounting screws made of stainless steel is also available. Use it in accordance with the operating environment.

(A switch mounting band is not included, so please order it separately.)

Construction

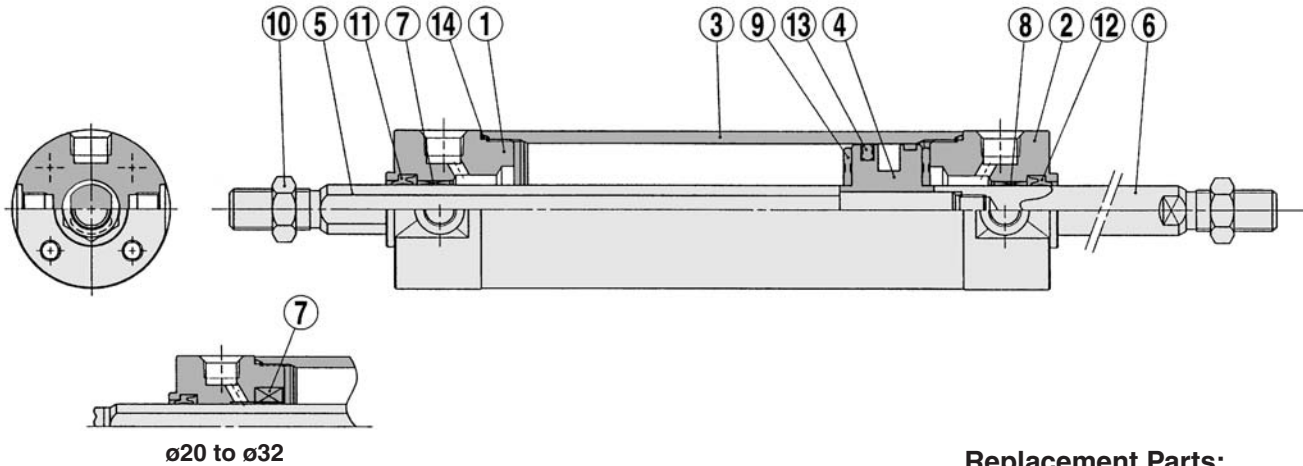

Component Parts

No.	Description	Material	Description
①	Rod cover A	Aluminum alloy	Clear hard anodized
②	Rod cover B	Aluminum alloy	Clear hard anodized
③	Cylinder tube	Aluminum alloy	Hard anodized
④	Piston	Aluminum alloy	Chromated
⑤	Piston rod A	Carbon steel *	Hard chrome plated
⑥	Piston rod B	Carbon steel **	Hard chrome plated
⑦	Non-rotating guide	Oil-impregnated sintered alloy	
⑧	Bushing	Oil-impregnated sintered alloy	ø40 or larger: Lead-bronze casted *
⑨	Bumper	Urethane	
⑩	Rod end nut	Rolled steel	
⑪	Rod seal A	NBR	
⑫	Rod seal B	NBR	
⑬	Piston seal	NBR	
⑭	Tube gasket	NBR	

* The material is stainless steel for ø20 to ø32.

** The material is stainless steel on auto switch equipped style ø20 and ø25.

*** A magnet is equipped on the piston of the cylinder with auto switch.

Replacement Parts:

Seal Kit for Rubber Bumper

Bore size (mm)	Kit no.	Contents
20	CG1KWN20-PS	Set of the nos. ⑩, ⑪, ⑫, ⑬
25	CG1KWN25-PS	
32	CG1KWN32-PS	
40	CG1KWN40-PS	
50	CG1KWN50-PS	
63	CG1KWN63-PS	

Basic Style with Rubber Bumper: CG1KWBN

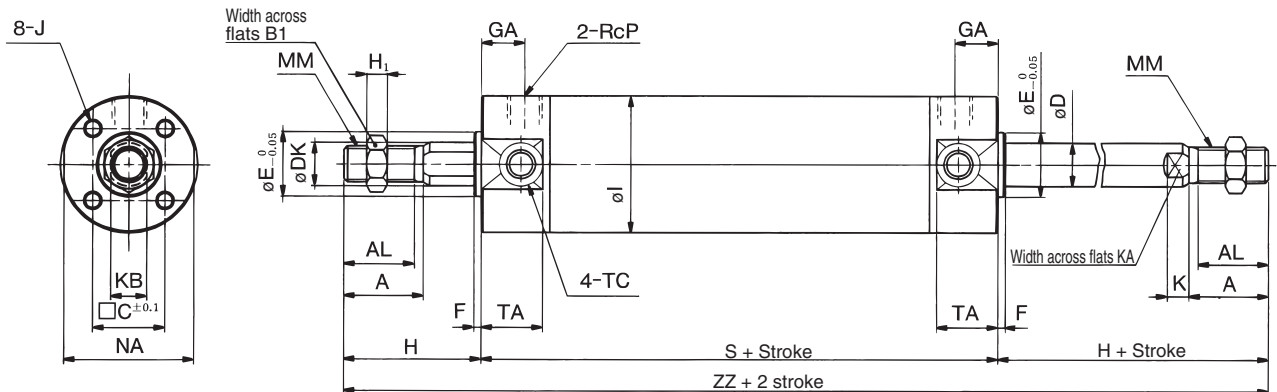

Bore size (mm)	Stroke range (mm)	A	AL	B ₁	C	D	DK	E	F	GA	H ₁	I	J	K	KA	KB	MM	NA	P	S
20	Up to 200	18	15.5	13	14	8	9.2	12	2	12	5	26	M4 x 0.7 depth 7	5	6	8	M8 x 1.25	24	1/8	77
25	Up to 300	22	19.5	17	16.5	10	11	14	2	12	6	31	M5 x 0.8 depth 7.5	5.5	8	10	M10 x 1.25	29	1/8	77
32	Up to 300	22	19.5	17	20	12	12	18	2	12	6	38	M5 x 0.8 depth 8	5.5	10	10	M10 x 1.25	35.5	1/8	79
40	Up to 500	30	27	19	26	16	16	25	2	13	8	47	M6 x 1 depth 12	6	14	14	M14 x 1.5	44	1/8	87
50	Up to 600	35	32	27	32	20	20	30	2	14	11	58	M8 x 1.25 depth 16	7	18	18	M18 x 1.5	55	1/4	102
63	Up to 600	35	32	27	38	20	20	32	2	14	11	72	M10 x 1.5 depth 16	7	18	18	M18 x 1.5	69	1/4	102

Bore size (mm)	TA	TC	H	ZZ
20	11	M5 x 0.8	35	147
25	11	M6 x 0.75	40	157
32	11	M8 x 1.0	40	159
40	12	M10 x 1.25	50	187
50	13	M12 x 1.25	58	218
63	13	M14 x 1.5	58	218

Note) Dimensions are the same as CG1W standard type. Refer to Best Pneumatics.
• Old number is CG1□N□-□-XC21 as made-to-order.

⚠ Precautions

Be sure to read before handling. Refer to Best Pneumatics for Safety Instructions and Actuator Precautions.

Caution on Handling/Disassembly

⚠ Caution

1. Avoid using the air cylinder in such a way that rotational torque would be applied to the piston rod.

- If rotational torque is applied, the non-rotating guide will become deformed, thus affecting the non-rotating accuracy. Refer to the table below for the approximate values of the allowable range of rotational torque.

Allowable rotational torque (N·m or less)	ø20	ø25, ø32	ø40, ø50, ø63
	0.2	0.25	0.44

- To screw a bracket or a nut onto the piston rod, make sure to retract the piston rod entirely, and place a wrench over the flat portion of the rod that protrudes.

Tighten it by giving consideration to prevent the tightening torque from being applied to the non-rotating guide.

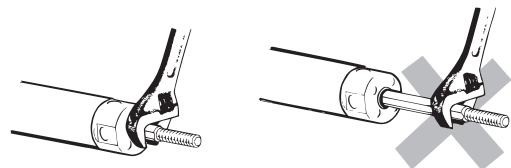

2. When replacing rod seals, please contact SMC.

Air leakage may be happened, depending on the position in which a rod seal is fitted. Thus, please contact SMC when replacing them.

Series CG1KW

Proper Auto Switch Mounting Position (Detection at stroke end) and Its Mounting Height

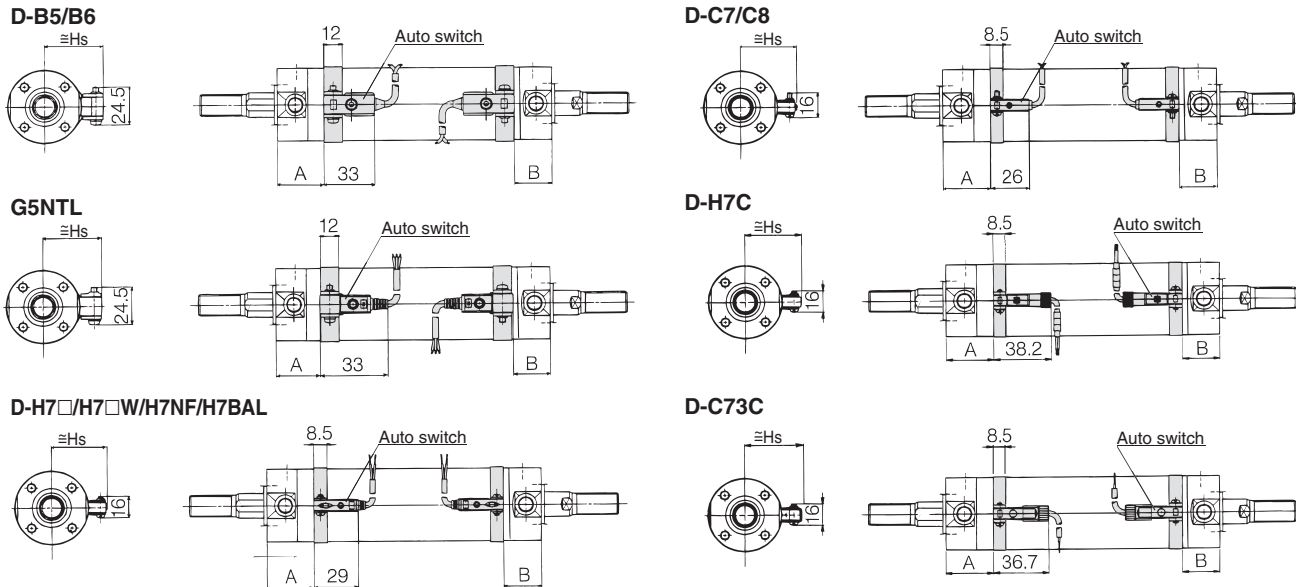

Bore size (mm)	D-C7, D-C8			D-C73C, D-C80C			D-B5, D-B6			D-B59W		
	A	B	Hs	A	B	Hs	A	B	Hs	A	B	Hs
20	30	28.5	24.5	30	28.5	27	24	22.5	27	25.5	27.5	
25	30	28.5	27	30	28.5	29.5	24	22.5	30	27	25.5	30
32	31	29.5	30.5	31	29.5	33	25	23.5	33.5	28	26.5	33.5
40	35.5	32.5	35	35.5	32.5	37.5	29.5	26.5	38	32.5	29.5	38
50	43	40.5	40.5	43	40.5	43	37	34.5	43.5	40	37.5	43.5
63	43	40.5	47.5	43	40.5	50	37	34.5	50.5	40	37.5	50.5

Bore size (mm)	D-H7□ D-H7□W		D-H7C D-H7BAL	D-H7NF			D-H7C		
	A	B	Hs	A	B	Hs	A	B	Hs
20	29	27.5	24.5	27.5	26	24.5	29	27.5	27.5
25	29	27.5	27	27.5	26	27	29	27.5	30
32	30	28.5	30.5	28.5	27	30.5	30	28.5	33.5
40	34.5	31.5	35	33	30	35	34.5	31.5	38
50	42	39.5	40.5	40.5	38	40.5	42	39.5	43.5
63	42	39.5	47.5	40.5	38	47.5	42	39.5	50.5

Operating Range

Auto switch model	Bore size (mm)					
	20	25	32	40	50	63
D-C7□/C80/C73C/C80C D-B5□/B64	8	10	9	10	10	11
D-B59W	13	13	14	14	14	17
D-H7NF, D-H7□/H7□W/H7BAL	4	4	4.5	5	6	6.5
D-H7C	7	8.5	9	10	9.5	10.5
D-G5NTL	4	4	4.5	5	6	6.5
D-G5NBL	35	40	40	45	45	45

* Since this is a guideline including hysteresis, not meant to be guaranteed. (Assuming approximately ±30% dispersion)
There may be the case it will vary substantially depending on an ambient environment.

Other than the applicable auto switches listed in "How to Order", the following auto switches can be mounted. For detailed specifications, refer to Best Pneumatics.

Type	Model	Electrical entry	Features	Applicable bore size (mm)
Reed switch	D-C80	Grommet	Without indicator light	20 to 63
	D-C80C	Connector		
	D-B53	Grommet	—	
	D-B64		Without indicator light	

*Timer equipped type, solid state auto switch (D-G5NTL) is also available.
*Wide range detection type, solid state auto switch (D-G5NBL) is also available.
*With pre-wide connector is available for D-G5NTL and D-G5NBL.

Air Cylinder: Direct Mount Type Double Acting, Single Rod

Series **CG1R**

ø20, ø25, ø32, ø40, ø50, ø63



How to Order

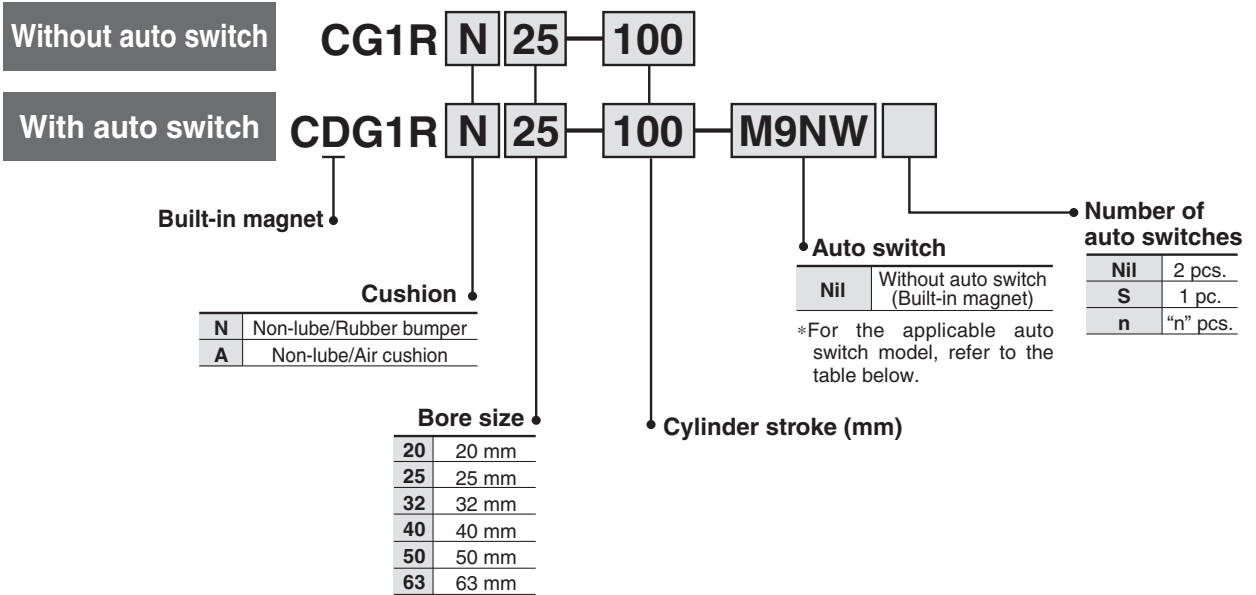

Applicable Auto Switch/Refer to Best Pneumatics for further information on auto switches.

Type	Special function	Electrical entry	Indicator light	Wiring (Output)	Load voltage		Auto switch model		Lead wire length (m) *				Pre-wire connector	Applicable load		
					DC	AC	Applicable bore size (mm)		0.5 (Nil)	3 (L)	5 (Z)	None (N)		IC circuit	Relay, PLC	
							20 to 63	80, 100								
Reed switch	—	Grommet	Yes	3-wire (NPN equivalent)	—	5 V	—	C76	—	●	●	—	—	—	—	IC circuit
				2-wire		12 V		B54		●	●	●	—	—	—	Relay, PLC
	24 V	100 V, 200 V	C73		—	●	●	●	—	—						
	Diagnostic indication (2-color indication)	Grommet	—	—	—	B59W		●	●	—	—	—	—	—	—	—
Solid state switch	—	Grommet	Yes	3-wire (NPN)	24 V	5 V, 12 V	—	M9N	G59	●	—	○	—	○	—	IC circuit
				3-wire (PNP)		12 V		M9P	G5P	●	—	○	—	○	—	—
				2-wire		5 V, 12 V		M9B	K59	●	—	○	—	○	—	—
				3-wire (NPN)		5 V, 12 V		M9NW	G59W	●	●	○	—	○	—	○
	3-wire (PNP)	12 V	M9PW		G5PW		●	●	○	—	○	—	—			
	Water resistant (2-color indication)	Grommet	—	—	—	—	—	M9BW	K59W	●	●	○	—	○	—	—
								2-wire	5 V, 12 V	M9BA	G5BA	●	●	○	—	○
	Diagnostic output (2-color indication)	—	—	—	—	—	—	—	G59F	●	●	○	—	○	—	—

* Lead wire length symbols: 0.5 m Nil (Example) C73C M9NW
 3 m L (Example) C73CL M9NL
 5 m Z (Example) C73CZ M9NZ
 None N (Example) C73CN

* Solid state switches marked with "○" are produced upon receipt of order.

- Since there are other applicable auto switches than listed, contact SMC for details.
- For details about auto switches with pre-wire connector, refer to Best Pneumatics.

Series CG1R

Series CG1R direct mount cylinder can be installed directly through the use of a square rod cover.

Space-saving has been realized.

Because it is a directly mounted style without using brackets, its overall length is shorter, and its installation pitch can be made smaller. Thus, the space that is required for installation has been dramatically reduced.



JIS Symbol

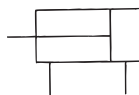

Made to Order Specifications

Symbol	Specifications
-XA□	Change of rod end shape
-XB6	Heat resistant cylinder (150°C)
-XB7	Cold resistant cylinder
-XB9	Low speed cylinder (10 to 50 mm/s)
-XB13	Low speed cylinder (5 to 50 mm/s)
-XC6	Piston rod and rod end nut made of stainless steel
-XC8	Adjustable stroke cylinder/Adjustable extension type
-XC9	Adjustable stroke cylinder/Adjustable retraction type
-XC13	Auto switch rail mounting
-XC20	Head cover axial port
-XC22	Fluoro rubber seals

Specifications

Bore size (mm)	20	25	32	40	50	63
Action	Double acting, Single rod					
Type	Non-lube					
Fluid	Air					
Proof pressure	1.5 MPa					
Maximum operating pressure	1.0 MPa					
Minimum operating pressure	0.05 MPa					
Ambient and fluid temperature	Without auto switch: -10 to 70°C (No freezing) With auto switch: -10 to 60°C (No freezing)					
Piston speed	50 to 1000 mm/s					
Thread tolerance	JIS Class 2					
Stroke length tolerance	Up to 300 ^{st+1.4} _o mm					
Cushion	Rubber bumper, Air cushion					

Weight

Bore size (mm)	20	25	32	40	50	63
Basic weight	0.14	0.23	0.35	0.57	1.04	1.49
Single knuckle joint	0.05	0.09	0.09	0.10	0.22	0.22
Double knuckle joint (With pin)	0.05	0.09	0.09	0.13	0.26	0.26
Additional weight per each 50 mm of stroke	0.05	0.07	0.09	0.15	0.22	0.26
Additional weight with air cushion	0.01	0.01	0.02	0.02	0.03	0.03

Calculation: (Example) CG1RN32-100
(ø32, 100 st)

•Basic weight..... 0.35
•Additional weight..... 0.09/50 st
•Cylinder stroke..... 100 st
0.35 + 0.09 x 100/50 = 0.53 kg

Accessory

	Mounting	Basic style
Standard equipment	Rod end nut	●
	Single knuckle joint	●
Option	Double knuckle joint * (With pin)	●

* Pin and snap ring are shipped together with double knuckle joint.

Standard Stroke

Bore size (mm)	Standard stroke * (mm)
20	25, 50, 75, 100, 125, 150
25, 32	25, 50, 75, 100, 125, 150, 200
40, 50, 63	25, 50, 75, 100, 125, 150, 200, 250, 300

* Other intermediate strokes can be manufactured upon receipt of order. Long strokes are not available. Spacers are not used for intermediate strokes.

Auto Switch Mounting Bracket Part No.

Auto switch model	Bore size (mm)					
	20	25	32	40	50	63
D-C7/C8	BMA2-020	BMA2-025	BMA2-032	BMA2-040	BMA2-050	BMA2-063
D-B5/B6	BA-01	BA-02	BA-32	BA-04	BA-05	BA-06
D-G5/K5						
D-M9	BMA2-020	BMA2-025	BMA2-032	BMA2-040	BMA2-050	BMA2-063
BJ3-1 (Adaptor piece)						

* Mounting screws set made of stainless steel
The following set of mounting screws made of stainless steel is also available. Use it in accordance with the operating environment. (A switch mounting band is not included, so please order it separately.)

Clean Series

10-CG1RN **Bore size** — **Stroke**

• Clean Series (With relief port)

The rod portion of the actuator has a double seal construction, and a relief port is provided to discharge the exhaust air directly outside of the clean room.

Thus, it can be used in a Class 100 clean room.

Specifications

Bore size (mm)	20, 25, 32, 40, 50, 63
Action	Double acting
Fluid	Air
Maximum operating pressure	1.0 MPa
Minimum operating pressure	0.05 MPa
Cushion	Rubber bumper
Piston speed	50 to 400 mm/s
Relief port size	M5 x 0.8

* Auto switch can be mounted.

For details, refer to the separate catalog, "Pneumatic Clean Series".

Copper-free

20-CG1R **Type** — **Bore size** — **Stroke**

• Copper-free

This cylinder eliminates any influences of copper ions or fluororesins on color CRTs.

Copper materials have been nickel plated or replaced with non-copper materials to prevent the generation of copper ions.

Specifications

Bore size (mm)	20, 25, 32, 40, 50, 63	
Action	Double acting	
Fluid	Air	
Maximum operating pressure	1.0 MPa	
Minimum operating pressure	0.05 MPa	
Cushion	Type N	With rubber bumper
	Type A	With air cushion
Relief port size	50 to 1000 mm/s	

Series CG1R

Construction

Basic style: Bottom mounting style/with rubber bumper

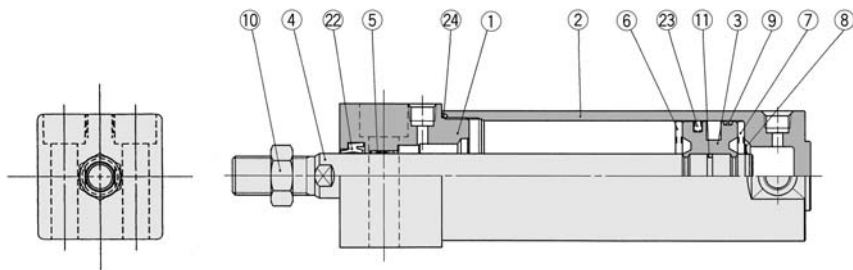

With air cushion

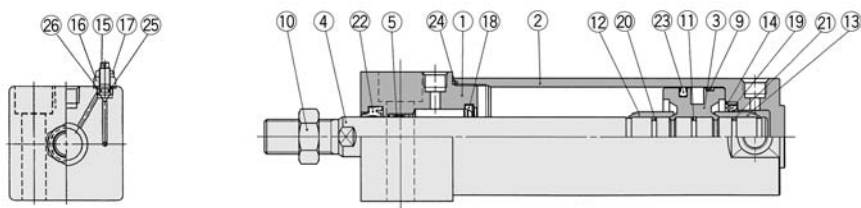

Component Parts

No.	Description	Material	Note
①	Rod cover	Aluminum alloy	Clear hard anodized
②	Tube cover	Aluminum alloy	Clear hard anodized
③	Piston	Aluminum alloy	Chromated
④	Piston rod	Carbon steel *	Hard chrome plated
⑤	Bushing	Oil-impregnated sintered alloy	ø40 or larger: Lead-bronze casted
⑥	Bumper A	Urethane	
⑦	Bumper B	Urethane	ø40 or larger: The same as bumper A
⑧	Snap ring	Stainless steel	
⑨	Wear ring	Resin	
⑩	Rod end nut	Rolled steel	Nickel plated
⑪	Piston gasket	NBR	
⑫	Cushion ring A	Brass	
⑬	Cushion ring B	Brass	ø32 or larger: The same as A

No.	Description	Material	Note
⑭	Seal retainer	Rolled steel	
⑮	Cushion valve	Rolled steel	Electroless nickel plated
⑯	Valve retainer	Rolled steel	Electroless nickel plated
⑰	Lock nut	Carbon steel	Nickel plated
⑱	Cushion seal A	Urethane	
⑲	Cushion seal B	Urethane	
⑳	Cushion ring gasket A	NBR	
㉑	Cushion ring gasket B	NBR	ø32 or larger: The same as A
㉒	Rod seal	NBR	
㉓	Piston seal	NBR	
㉔	Tube gasket	NBR	
㉕	Valve seal	NBR	
㉖	Valve retaining gasket	NBR	

Note) In the case of cylinders with auto switches, rubber magnets are installed in the piston.

*The material is stainless steel on auto switch equipped styles ø20 and ø25.

Replacement parts/Seal kit are the same as standard type, double acting, single rod. Refer to Best Pneumatics.

Basic Style with Bottom Mounting

With rubber bumper: CG1RN

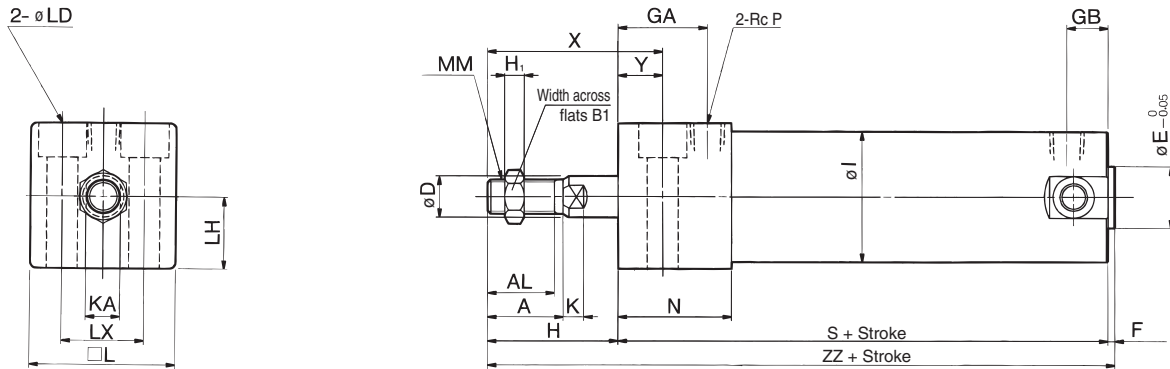

With air cushion: CG1RA

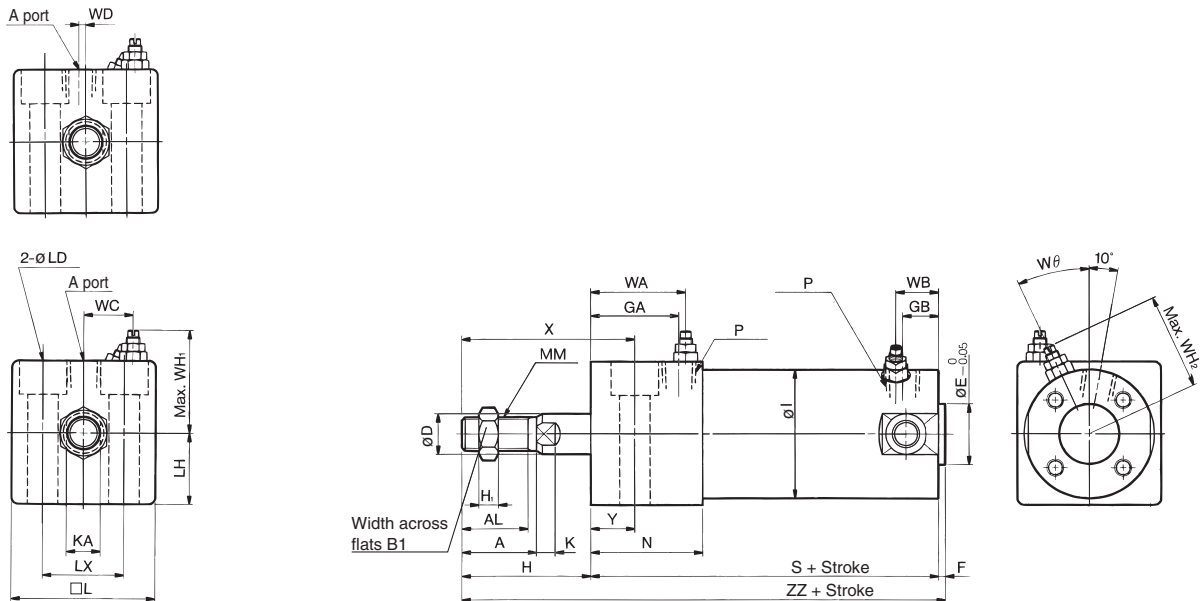

Bore size (mm)	Stroke range (mm)	A	AL	B ₁	D	E	F	GA	GB	H	H ₁	I	K	KA	L	LD	LH	LX	MM	N	P	S	X	Y	ZZ
20	Up to 150	18	15.5	13	8	12	2	20	10	27	5	26	5	6	30.4	ø5.5, ø9.5 counterbore depth 6	15	18	M8 x 1.25	27	1/8	75	38	11	104
25	Up to 200	22	19.5	17	10	14	2	22	10	32	6	31	5.5	8	36.4	ø6.6, ø11 counterbore depth 7	18	22	M10 x 1.25	29	1/8	77	44	12	111
32	Up to 200	22	19.5	17	12	18	2	26	10	32	6	38	5.5	10	42.4	ø9, ø14 counterbore depth 9	21	24	M10 x 1.25	33	1/8	83	45	13	117
40	Up to 300	30	27	19	16	25	2	30	10	39	8	47	6	14	52.4	ø11, ø17.5 counterbore depth 12	26	32	M14 x 1.5	37	1/8	94	55	16	135
50	Up to 300	35	32	27	20	30	2	33	12	45	11	58	7	18	64.5	ø14, ø20 counterbore depth 14	32	41	M18 x 1.5	44	1/4	108	62	17	155
63	Up to 300	35	32	27	20	32	2	39	12	45	11	72	7	18	76.6	ø18, ø26 counterbore depth 18	38	46	M18 x 1.5	50	1/4	114	64	19	161

With Air Cushion

Bore size (mm)	Stroke range (mm)	P	WA	WB	WC	WD	WH	WH ₂	Wθ
20	Up to 150	M5 x 0.8	22	15	8.5	2	25	23	30°
25	Up to 200	M5 x 0.8	24	15	11	2	27.5	25	30°
32	Up to 200	Rc 1/8	28	15	14.5	—	30.5	28.5	25°
40	Up to 300	Rc 1/8	32	15	18.5	—	35.5	33	20°
50	Up to 300	Rc 1/4	36	17	22	—	43.5	40.5	20°
63	Up to 300	Rc 1/4	42	17	29	—	49.5	47.5	20°

Series CG1R

Proper Auto Switch Mounting Position (Detection at stroke end) and Its Mounting Height

D-C7

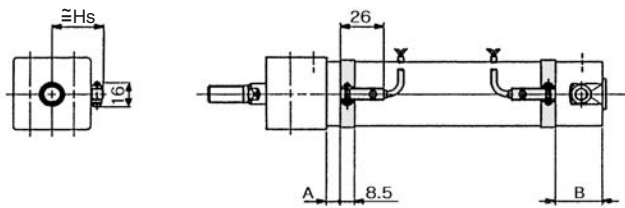

D-G5, D-K5

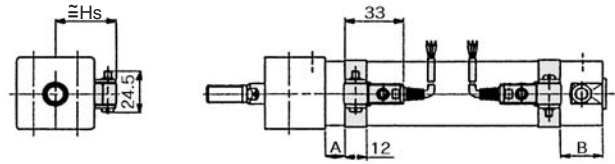

D-H7

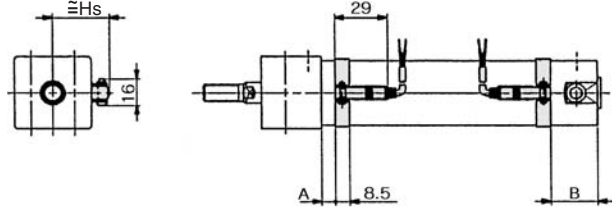

D-C73C

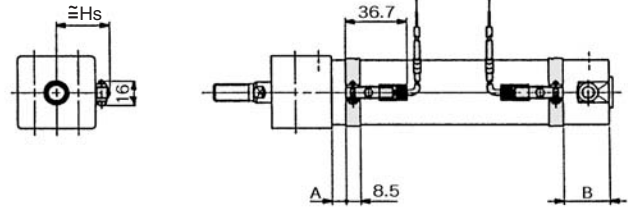

D-B5

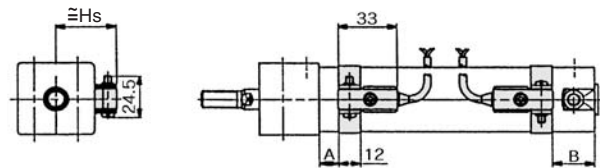

D-H7C

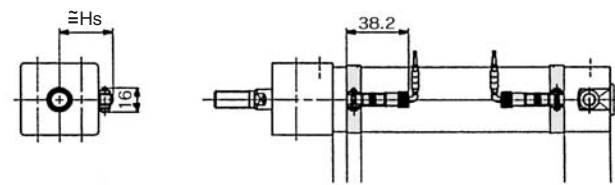

Proper Auto Switch Mounting Position

Auto switch model	D-C7/C8 D-C73C/ C80C		D-B5/B6		D-B59W		D-M9 D-M9W D-M9A		D-G5NTL	
	A	B	A	B	A	B	A	B	A	B
20	9	20.5	3	15.5	6	17.5	8	19.5	4.5	16
25	9	20.5	3	15.5	6	17.5	8	19.5	4.5	16
32	10	21.5	4	15.5	7	18.5	9	20.5	5.5	17
40	14.5	23.5	8.5	19	11.5	20.5	13.5	22.5	10	19
50	17	28.5	11	22.5	14	25.5	16	27.5	12.5	24
63	17	28.5	11	22.5	14	25.5	16	27.5	12.5	24

Auto Switch Mounting Height

D-M9 D-M9W D-M9A	D-C73C D-C80C	D-B5/B6 D-B59W D-G5NTL D-H7C
Hs	Hs	Hs
24.5	27	27.5
27	29.5	30
30.5	33	33.5
35	37.5	38
40.5	43	43.5
47.5	50	50.5

Operating Range

Auto switch model	Bore size (mm)					
	20	25	32	40	50	63
D-C7□/C80/C73C/C80C D-B5□/B64	8	10	9	10	10	11
D-B59W	13	13	14	14	14	17
D-M9/D-M9W/D-M9A	4	4	4.5	5	6	6.5
D-H7C	7	8.5	9	10	9.5	10.5
D-G5NTL	4	4	4.5	5	6	6.5
D-G5NBL	35	40	40	45	45	45

* Since this is a guideline including hysteresis, not meant to be guaranteed. (Assuming approximately $\pm 30\%$ dispersion)
There may be the case it will vary substantially depending on an ambient environment.

Other than the applicable auto switches listed in "How to Order", the following auto switches can be mounted.
For detailed specifications, refer to Best Pneumatics.

Type	Model	Electrical entry	Features	Applicable bore size (mm)
Reed switch	D-C80	Grommet	Without indicator light	20 to 63
	D-C80C	Connector		
	D-B53	Grommet	—	
	D-B64		Without indicator light	

* Timer equipped type, solid state auto switch (D-G5NTL) is also available.
* Wide range detection type, solid state auto switch (D-G5NBL) is also available.
* With pre-wire connector is available for D-G5NTL and D-G5NBL.

Air Cylinder: Direct Mount, Non-rotating Rod Double Acting, Single Rod

Series **CG1KR**

ø20, ø25, ø32, ø40, ø50, ø63



How to Order

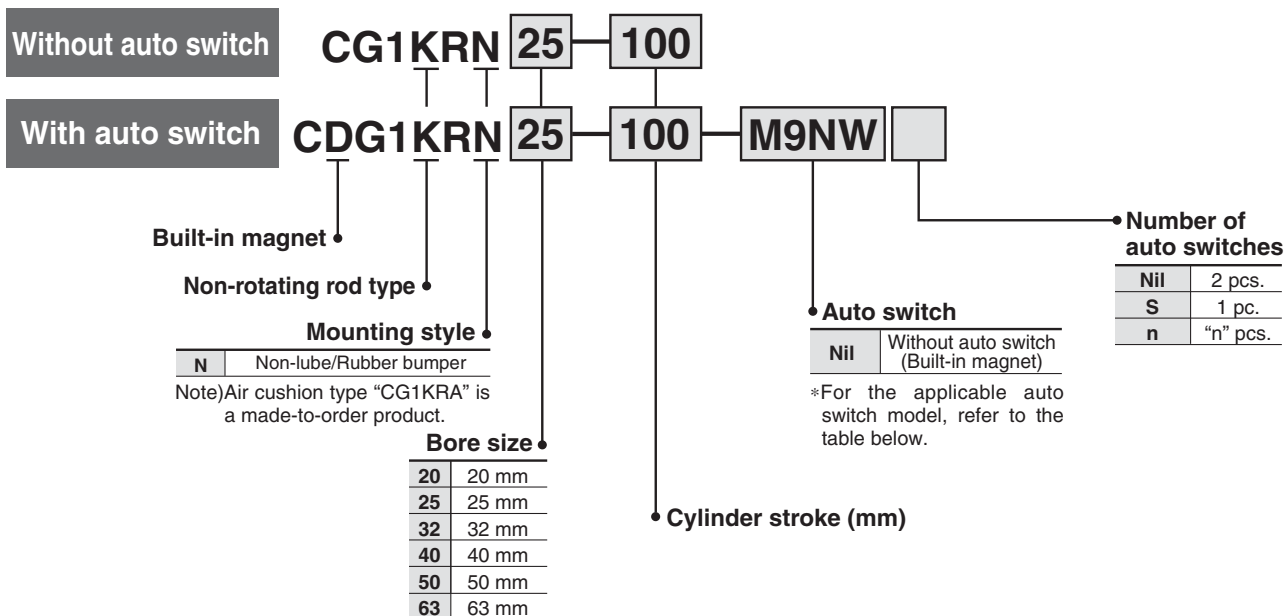

Applicable Auto Switch/Refer to Best Pneumatics for further information on auto switches.

Type	Special function	Electrical entry	Indicator light	Wiring (Output)	Load voltage		Auto switch model		Lead wire length (m)*				Pre-wire connector	Applicable load		
					DC	AC	Applicable bore size (mm)		0.5 (Nil)	3 (L)	5 (Z)	None (N)		IC circuit	Relay, PLC	
Reed switch	—	Grommet	Yes	3-wire (NPN equivalent)	—	5 V	—	C76	—	●	●	—	—			—
				2-wire	24 V	12 V	100 V, 200 V	B54	—	●	●	●	—	—	—	Relay, PLC
	Connector	—	—	100 V	C73	—	●	●	●	●	—	—				
Solid state switch	Diagnostic indication (2-color indication)	Grommet	Yes	2-wire	—	—	—	B59W	—	●	●	—	—	—	—	—
	—	Grommet	Yes	3-wire (NPN)	24 V	5 V, 12 V	—	M9N	G59	●	—	○	—	○	IC circuit	Relay, PLC
				3-wire (PNP)				M9P	G5P	●	—	○	—	○		
				2-wire				M9B	K59	●	—	○	—	○		
				3-wire (NPN)				M9NW	G59W	●	●	○	—	○		
				3-wire (PNP)				M9PW	G5PW	●	●	○	—	○		
				2-wire				M9BW	K59W	●	●	○	—	○		
Water resistant (2-color indication)	—	—	—	—	—	—	—	—	—	—	—	—	—	—		
Diagnostic output (2-color indication)	—	—	—	4-wire (NPN)	5 V, 12 V	—	—	G59F	●	●	○	—	○	IC circuit	—	

* Lead wire length symbols: 0.5 m Nil (Example) C73C M9NW
 3 m L (Example) C73CL M9NL
 5 m Z (Example) C73CZ M9NZ
 None N (Example) C73CN

* Solid state switches marked with "○" are produced upon receipt of order.

- Since there are other applicable auto switches than listed, contact SMC for details.
- For details about auto switches with pre-wire connector, refer to Best Pneumatics.

Series CG1KR

Series CG1KR direct mount, non-rotating rod type cylinder can be installed directly through the use of a square rod cover.

Space-saving has been realized.

Because it is a directly mounted style without using brackets, its overall length is shorter, and its installation pitch can be made smaller. Thus, the space that is required for installation has been dramatically reduced.



JIS Symbol

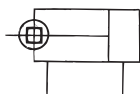

Specifications

Bore size (mm)	20	25	32	40	50	63
Action	Double acting, Single rod					
Type	Non-lube					
Fluid	Air					
Proof pressure	1.5 MPa					
Maximum operating pressure	1.0 MPa					
Minimum operating pressure	0.05 MPa					
Ambient and fluid temperature	Without auto switch: -10 to 70°C (No freezing) With auto switch: -10 to 60°C (No freezing)					
Piston speed	50 to 500 mm/s					
Thread tolerance	JIS Class 2					
Stroke length tolerance	Up to 300 ^{st+1.4} ₀ mm					
Cushion	Rubber bumper					
Rod non-rotating accuracy	±1°	±0.8°	±0.8°	±0.8°	±0.5°	±0.5°

Weight

Bore size (mm)	20	25	32	40	50	63
Basic weight	0.14	0.24	0.35	0.56	1.04	1.48
Single knuckle joint	0.05	0.09	0.09	0.10	0.22	0.22
Double knuckle (With pin)	0.05	0.09	0.09	0.13	0.26	0.26
Additional weight per each 50 mm of stroke	0.05	0.07	0.09	0.15	0.22	0.26

Calculation: (Example) CG1KRN32-100 (ø32, 100 st)

- Basic weight.....0.35
- Additional weight.....0.09/50 st
- Cylinder stroke.....100 st
- 0.35 + 0.09 x 100/50 = 0.53 kg

Standard Stroke

Bore size (mm)	Standard stroke (mm) *
20	25, 50, 75, 100, 125, 150
25, 32	25, 50, 75, 100, 125, 150, 200
40, 50, 63	25, 50, 75, 100, 125, 150, 200, 250, 300

* Other intermediate strokes can be manufactured upon receipt of order. Long strokes are not available.
Spacers are not used for intermediate strokes.

Accessory

	Mounting	Basic style
Standard equipment	Rod end nut	●
Option	Single knuckle joint	●
	Double knuckle joint * (With pin)	●

* Pin and snap ring are shipped together with double knuckle joint.



Made to Order Specifications

Symbol	Specifications
-XC8	Adjustable stroke cylinder/Adjustable extension type
-XC9	Adjustable stroke cylinder/Adjustable retraction type
-XC20	Head cover axial port

Auto Switch Mounting Bracket Part No.

Auto switch model	Bore size (mm)					
	20	25	32	40	50	63
D-C7/C8	BMA2-020	BMA2-025	BMA2-032	BMA2-040	BMA2-050	BMA2-063
D-B5/B6	BA-01	BA-02	BA-32	BA-04	BA-05	BA-06
D-G5/K5						
D-M9	BMA2-020	BMA2-025	BMA2-032	BMA2-040	BMA2-050	BMA2-063



* Mounting screws set made of stainless steel
The following set of mounting screws made of stainless steel is also available. Use it in accordance with the operating environment.
(A switch mounting band is not included, so please order it separately.)

Caution on Handling/Disassembly

⚠ Caution

1. Avoid using the air cylinder in such a way that rotational torque would be applied to the piston rod.

- If rotational torque is applied, the non-rotating guide will become deformed, thus affecting the non-rotating accuracy. Refer to the table below for the allowable range of the allowable range of rotational torque.

Allowable rotational torque (N·m or less)	ø20	ø25, ø32	ø40, ø50, ø63
	0.2	0.25	0.44

- To screw a bracket or a nut onto the piston rod, make sure to retract the piston rod entirely, and place a wrench over the flat portion of the rod that protrudes.

Tighten it by giving consideration to prevent the tightening torque from being applied to the non-rotating guide.

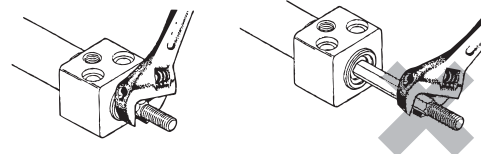

2. When replacing rod seals, please contact SMC.

Air leakage may be happened, depending on the position in which a rod seal is fitted. Thus, please contact SMC when replacing them.



Construction

Non-rotating rod type/Bottom mounting style

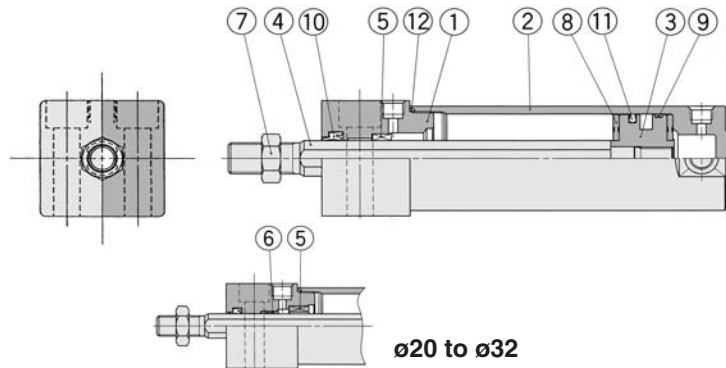

ø20 to ø32

Component Parts

No.	Description	Material	Note
①	Rod cover	Aluminum alloy	Clear hard anodized
②	Tube cover	Aluminum alloy	Clear hard anodized
③	Piston	Aluminum alloy	Chromated
④	Piston rod	Carbon steel *	Hard chrome plated
⑤	Non-rotating guide	Oil-impregnated sintered alloy	
⑥	Bushing	Oil-impregnated sintered alloy	ø20 to ø32 only
⑦	Rod end nut	Rolled steel	Nickel plated
⑧	Bumper	Urethane	
⑨	Wear ring	Resin	
⑩	Rod seal	NBR	
⑪	Piston seal	NBR	
⑫	Tube gasket	NBR	

* The material is stainless steel for ø20, ø25 and ø32.

Replacement parts/Seal kits are the same as double acting, non-rotating rod type. Refer to Best Pneumatics.

Basic Style with Bottom Mounting: CG1KRN

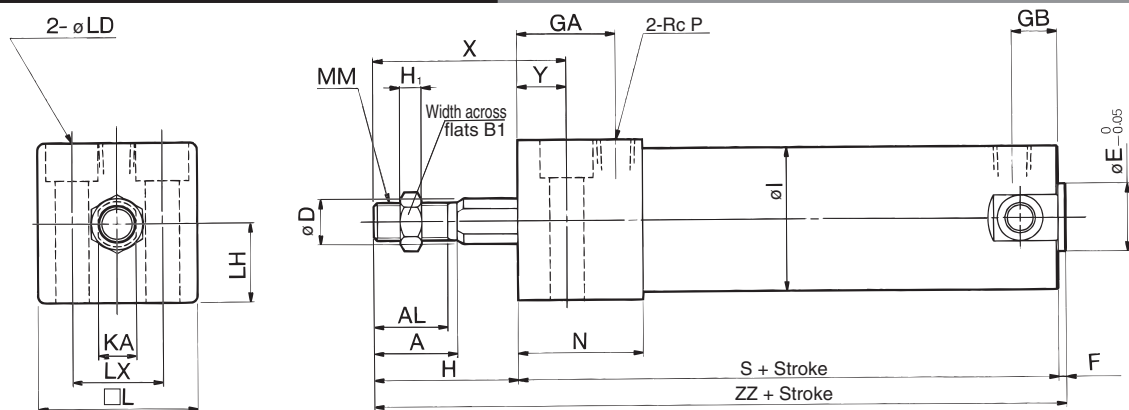

Bore size (mm)	Stroke range (mm)	A	AL	B ₁	D	E	GA	GB	H	H ₁	I	KA	L	LD	LH	LX	MM	N	P	S	X	Y	ZZ
20	Up to 150	18	15.5	13	9.2	12	20	10	27	5	26	8	30.4	ø5.5, ø9.5 counterbore depth 6	15	18	M8 x 1.25	27	1/8	75	38	11	104
25	Up to 200	22	19.5	17	11	14	22	10	32	6	31	10	36.4	ø6.6, ø11 counterbore depth 7	18	22	M10 x 1.25	29	1/8	77	44	12	111
32	Up to 200	22	19.5	17	12	18	26	10	32	6	38	10	42.4	ø9, ø14 counterbore depth 9	21	24	M10 x 1.25	33	1/8	83	45	13	117
40	Up to 300	30	27	19	16	25	30	10	39	8	47	14	52.4	ø11, ø17.5 counterbore depth 12	26	32	M14 x 1.5	37	1/8	94	55	16	135
50	Up to 300	35	32	27	20	30	33	12	45	11	58	18	64.5	ø14, ø20 counterbore depth 14	32	41	M18 x 1.5	44	1/4	108	62	17	155
63	Up to 300	35	32	27	20	32	39	12	45	11	72	18	76.6	ø18, ø26 counterbore depth 18	38	46	M18 x 1.5	50	1/4	114	64	19	161

Air Cylinder: Low Friction Type Double Acting, Single Rod

Series **CG1□Q** ø20, ø25, ø32, ø40, ø50, ø63, ø80, ø100



How to Order

Without auto switch

CG1 **L** **Q** **25** **100** **F**

With auto switch

CDG1 **L** **Q** **25** **100** **F** **H7BW** □

Built-in magnet

Mounting style

B	Basic style
L	Axial foot style
F	Rod side flange style
G	Head side flange style
U*	Rod side trunnion style
T*	Head side trunnion style
D	Clevis style

* Not available for ø80 and ø100.

Note) Mounting brackets are shipped together, (but not assembled).

Low friction type

Bore size

20	20 mm
25	25 mm
32	32 mm
40	40 mm
50	50 mm
63	63 mm
80	80 mm
100	100 mm

Cylinder stroke (mm)

Refer to "Standard Stroke" on Best Pneumatics.

Auto switch

Nil	Without auto switch (Built-in magnet)
------------	---------------------------------------

*For the applicable auto switch model, refer to the table below.

Low friction direction

F	When pressurized at head end
B	When pressurized at rod end

Number of auto switches

Nil	2 pcs.
S	1 pc.
n	"n" pcs.

Applicable Auto Switch/Refer to Best Pneumatics for further information on auto switches.

Type	Special function	Electrical entry	Indicator light	Wiring (Output)	Load voltage		Auto switch model		Lead wire length (m) *				Pre-wire connector	Applicable load		
					DC	AC	Applicable bore size (mm)		0.5 (Nil)	3 (L)	5 (Z)	None (N)		IC circuit	Relay, PLC	
Reed switch	—	Grommet	Yes	3-wire (NPN equivalent)	—	5 V	—	C76	—	●	●	—	—			—
								B54		●	●	●	—	—		
	Diagnostic indication (2-color indication)	Connector		2-wire	24 V	—	—	100 V, 200 V	C73	—	●	●	●	—	—	—
									C73C	—	●	●	●	●		
Solid state switch	—	Grommet	Yes	3-wire (NPN)	24 V	5 V, 12 V	—	M9N	G59	●	—	○	—	—	—	
				3-wire (PNP)				M9P	G5P	●	—	○	—			○
	2-wire			M9B				K59	●	—	○	—	○	—	—	
	3-wire (NPN)			M9NW				G59W	●	●	○	—	○			
	3-wire (PNP)			M9PW				G5PW	●	●	○	—	○	—	—	
	2-wire			M9BW				K59W	●	●	○	—	○			
	Water resistant (2-color indication)			M9BA				G5BA	●	●	○	—	○	—	—	
	Diagnostic output (2-color indication)			—				G59F	●	●	○	—	○			IC circuit

* Lead wire length symbols: 0.5 m.....Nil (Example) C73C M9NW
 3 m L (Example) C73CL M9NL
 5 m Z (Example) C73CZ M9NZ
 None N (Example) C73CN

* Solid state switches marked with "○" are produced upon receipt of order.

- Since there are other applicable auto switches than listed, contact SMC for details.
- For details about auto switches with pre-wire connector, refer to Best Pneumatics.

Application Example

Low friction cylinder is used in combination with precision regulator (Series IR).

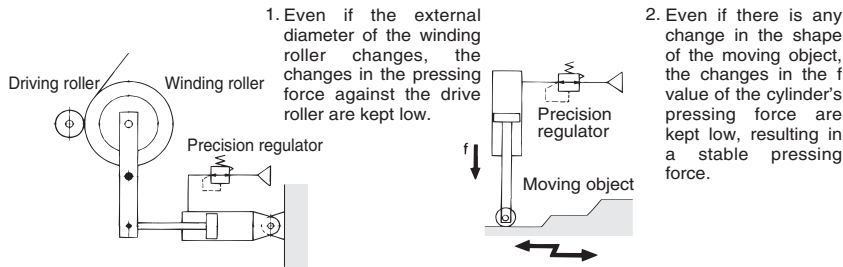

Specifications

Bore size (mm)	20	25	32	40	50	63	80	100
Action	Double acting, Single rod							
Type	Non-lube							
Fluid	Air							
Proof pressure	1.05 MPa							
Maximum operating pressure	0.7 MPa							
Minimum operating pressure	0.025 MPa				0.01 MPa			
Ambient and fluid temperature	Without auto switch: -10 to 70°C (No freezing) With auto switch: -10 to 60°C (No freezing)							
Piston speed	500 mm/s							
Stroke length tolerance	Up to 1000 ^{+1.4} ₀ mm							
Cushion	None				Rubber bumper			
Mounting	Basic style, Axial foot style, Rod side flange style, Head side flange style, Rod side trunnion style, Head side trunnion style, Clevis style (Used for changing the port location by 90°.)							
Direction of low friction	One direction (Refer to "Selection of the Direction".)							
Allowable leakage	0.5 dl/min (ANR) or less							

* Long stroke applies to the axial foot type and the rod side flange type. Rod/Head side trunnion styles are not available for bore sizes ø80 and ø100.

Accessory

Mounting		Basic style	Axial foot style	Rod side flange style	Head side flange style	Rod side trunnion style	Head side trunnion style	Clevis style
Standard equipment	Rod end nut	●	●	●	●	●	●	●
	Clevis pin	—	—	—	—	—	—	●
Option	Single knuckle joint	●	●	●	●	●	●	●
	Double knuckle joint (With pin) **	●	●	●	●	●	●	●
	Pivot bracket	—	—	—	—	●*	●*	●

* Not available for bore size ø80 and ø100.

** Pin and snap ring are shipped together with double knuckle joint.

Standard Stroke

Bore size (mm)	Standard stroke (mm) ⁽¹⁾	Long stroke (mm) ⁽²⁾
20	25, 50, 75, 100, 125, 150, 200	201 to 350
25		301 to 400
32		301 to 450
40	25, 50, 75, 100, 125, 150, 200	301 to 500
50, 63	250, 300	301 to 1000
80		301 to 1000
100		301 to 1000

Note1) Other intermediate strokes can be manufactured upon receipt of order.

Note2) The longer the stroke is, the greater the sliding resistance could become, due to the deflection of the piston rod. Therefore, consider installing a guide, etc. before using.

Note3) Please contact SMC for applications that exceed the stroke range shown above. (The maximum manufacturable stroke is 1500 mm.)

Designed with a low sliding resistance of the piston, this air cylinder is ideal for applications such as contact pressure control, which requires smooth movements at low pressures.

Low sliding resistance

Stable sliding resistance

The sliding resistance remains stable even when the operating pressure changes.

Long strokes can be manufactured.

Auto switches can be mounted.



JIS Symbol

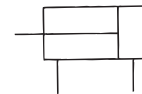

Made to Order Specifications

Symbol	Specifications
-XA□	Change of rod end shape
-XC6	Piston rod and rod end nut made of stainless steel

Series CG1□Q

Sliding Resistance of the Low Friction Side

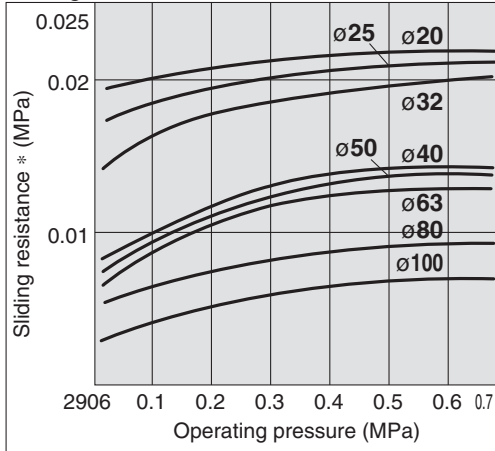

* Conversion into the cylinder operating pressure.

Selecting the Low Friction Direction

1. To use the air cylinder as a balancer, etc., pressurize it only from one of the ports as shown in the application example, and keep the other port open to the atmosphere.

To operate by applying pressure from the rod cover port:

Low friction direction B type (Application example (1))

To operate by applying pressure from the head cover port:

Low friction direction F type (Application example (2))

In either case, if the piston rod is moved by an external force, it will operate with low friction for both in the extending and retracting directions.

2. When it is necessary to operate it as an ordinary double acting cylinder at an even lower operating speeds, use a low speed cylinder.

Operating Precautions

Warning

1. In the direction of low friction operation, speed control must be effected through the meter-in system.

With meter-out control, the exhaust pressure will increase and create a greater sliding resistance.

Weight

Bore size (mm)		20	25	32	40	50	63	80	100
Basic weight	Basic style	0.11	0.18	0.28	0.44	0.83	1.17	2.23	3.43
	Axial foot style	0.22	0.31	0.44	0.66	1.31	1.89	3.19	5.18
	Flange style	0.19	0.28	0.42	0.64	1.17	1.67	2.94	4.78
	Trunnion style	0.12	0.20	0.31	0.49	0.97	1.31	—	—
	Clevis style	0.16	0.26	0.43	0.67	1.23	1.85	2.94	4.71
Pivot bracket		0.08	0.09	0.17	0.25	0.44	0.80	0.98	1.75
Single knuckle joint		0.05	0.09	0.09	0.10	0.22	0.22	0.39	0.57
Double knuckle joint (With pin)		0.05	0.09	0.09	0.13	0.26	0.26	0.64	1.31
Additional weight per each 50 mm of stroke		0.05	0.07	0.09	0.15	0.22	0.26	0.35	0.49

Calculation (Example) CG1LQ20-100B (Foot style, ø20, 100 st)

- Basic weight..... 0.22 (Foot, ø20)
- Additional weight..... 0.05/50st
- Cylinder stroke..... 100st
- 0.22 + 0.05 x 100/50 = 0.32 kg

Mounting Bracket Part No.

Mounting bracket	Bore size (mm)							
	20	25	32	40	50	63	80	100
Axial foot *	CG-L020	CG-L025	CG-L032	CG-L040	CG-L050	CG-L063	CG-L080	CG-L100
Flange	CG-F020	CG-F025	CG-F032	CG-F040	CG-F050	CG-F063	CG-F080	CG-F100
Trunnion	CG-T020	CG-T025	CG-T032	CG-T040	CG-T050	CG-T063	—	—
Clevis	CG-D020	CG-D025	CG-D032	CG-D040	CG-D050	CG-D063	CG-D080	CG-D100
Pivot bracket **	CG-020-24A	CG-025-24A	CG-032-24A	CG-040-24A	CG-050-24A	CG-063-24A	CG-080-24A	CG-100-24A



* Order two foot brackets per cylinder.

** Clevis pin, snap ring and mounting bolt are shipped for the clevis style.

*** Mounting bolts are shipped together for foot style and flange style.

Auto Switch Mounting Bracket Part No.

Auto switch model	Bore size (mm)							
	20	25	32	40	50	63	80	100
D-C7/C8	BMA2-020	BMA2-025	BMA2-032	BMA2-040	BMA2-050	BMA2-063	—	—
D-B5/B6	BA-01	BA-02	BA-32	BA-04	BA-05	BA-06	BA-08	BA-10
D-G5/K5	—	—	—	—	—	—	—	—
D-M9	BMA2-020	BMA2-025	BMA2-032	BMA2-040	BMA2-050	BMA2-063	—	—
BJ3-1 (Adaptor piece)								



* Mounting screws set made of stainless steel

The following set of mounting screws made of stainless steel is also available. Use it in accordance with the operating environment.

(A switch mounting band is not included, so please order it separately.)

With Auto Switch

Auto switches can be mounted. Mounting position/height is the same as the double acting/single rod style. Refer to Best Pneumatics.

Other than the applicable auto switches listed in "How to Order", the following auto switches can be mounted. For detailed specifications, refer to Best Pneumatics.

Type	Model	Electrical entry	Features	Applicable bore size (mm)
Reed switch	D-C80	Grommet	Without indicator light	20 to 63
	D-C80C	Connector		
	D-B53	Grommet	—	20 to 100
	D-B64		Without indicator light	

* Timer equipped type, solid state auto switch (D-G5NTL) is also available.

* Wide range detection type, solid state auto switch (D-G5NBL) is also available.

* With pre-wire connector is available for D-G5NTL and D-G5NBL.

Construction

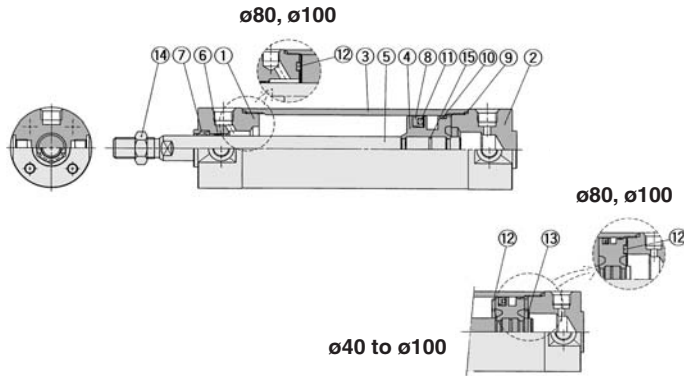

Component Parts

No.	Description	Material	Note
①	Rod cover	Aluminum alloy	Clear hard anodized
②	Head cover	Aluminum alloy	Clear hard anodized
③	Cylinder tube	Aluminum alloy	Hard anodized
④	Piston	Aluminum alloy	Chromated
⑤	Piston rod	Carbon steel *	Hard chrome plated
⑥	Bushing	Oil impregnated sintered alloy	ø40 and larger are lead-bronze casted
⑦	Rod seal	NBR	
⑧	Piston seal	NBR	
⑨	Tube gasket	NBR	
⑩	Wear ring	Resin	
⑪	Back up O-ring	NBR	
⑫	Bumper	Urethane	
⑬	Snap ring	Stainless steel	
⑭	Rod end nut	Rolled steel	Nickel plated
⑮	Piston gasket	NBR	

Replacement Parts: Seal Kit

Bore size (mm)	Kit no.	Contents
20	CG1Q20-PS	Set of the nos. ⑦, ⑧, ⑨, ⑩
25	CG1Q25-PS	
32	CG1Q32-PS	
40	CG1Q40-PS	
50	CG1Q50-PS	
63	CG1Q63-PS	
80	CG1Q80-PS	
100	CG1Q100-PS	

* Stainless steel is used as the material for ø20 and ø25 cylinder with auto switch.

* A magnet is equipped with the piston for cylinders with auto switch.

Basic Style: CG1BQ

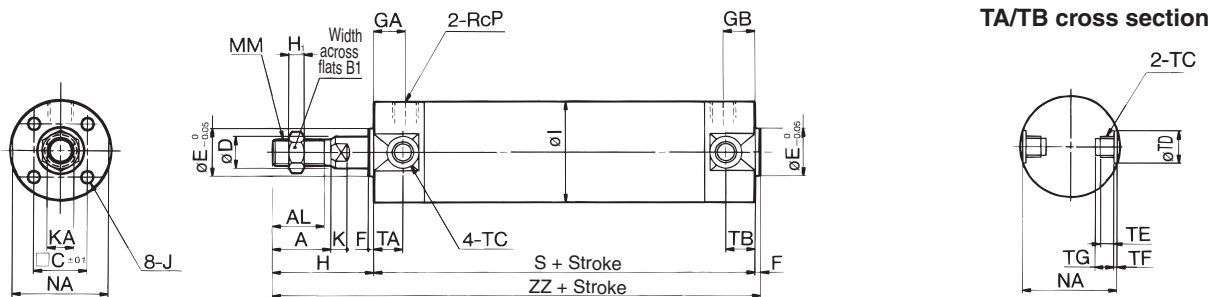

TA/TB Cross Section

Bore size (mm)	TC*	TDH9	TE	TF	TG
20	M5 x 0.8	8 ^{+0.08} ₀	4	0.5	5.5
25	M6 x 0.75	10 ^{+0.08} ₀	5	1	6.5
32	M8 x 1.0	12 ^{+0.08} ₀	5.5	1	7.5
40	M10 x 1.25	14 ^{+0.08} ₀	6	1.25	8.5
50	M12 x 1.25	16 ^{+0.08} ₀	7.5	2	10
63	M14 x 1.5	18 ^{+0.08} ₀	11.5	3	14.5

* Trunnion mounting taps with width across flats NA are not attached for bore sizes ø80 and ø100.

Bore size (mm)	Stroke range (mm)	A	AL	B ₁	C	D	E	F	GA	GB	H	H ₁	I	J	K	KA	MM	NA	P	S	TA	TB	ZZ
20	Up to 350	18	15.5	13	14	8	12	2	12	12	35	5	26	M4 x 0.7 depth 7	5	6	M8 x 1.25	24	1/8	77	11	11	114
25	Up to 400	22	19.5	17	16.5	10	14	2	12	12	40	6	31	M5 x 0.8 depth 7.5	5.5	8	M10 x 1.25	29	1/8	77	11	11	119
32	Up to 450	22	19.5	17	20	12	18	2	12	12	40	6	38	M5 x 0.8 Depth 8	5.5	10	M10 x 1.25	35.5	1/8	79	11	11	121
40	Up to 500	30	27	19	26	16	25	2	13	13	50	8	47	M6 x 1 depth 12	6	14	M14 x 1.5	44	1/8	87	12	12	139
50	Up to 1000	35	32	27	32	20	30	2	14	14	58	11	58	M8 x 1.25 depth 16	7	18	M18 x 1.5	55	1/4	102	13	13	162
63	Up to 1000	35	32	27	38	20	32	2	14	14	58	11	72	M10 x 1.5 depth 16	7	18	M18 x 1.5	69	1/4	102	13	13	162
80	Up to 1000	40	37	32	50	25	40	3	20	20	71	13	89	M10 x 1.5 depth 22	10	22	M22 x 1.5	80	3/8	122	—	—	196
100	Up to 1000	40	37	41	60	30	50	3	20	20	71	16	110	M12 x 1.75 depth 22	10	26	M26 x 1.5	100	1/2	122	—	—	196

Series CG1□Q

With Mounting Bracket

Axial foot style: CG1LQ

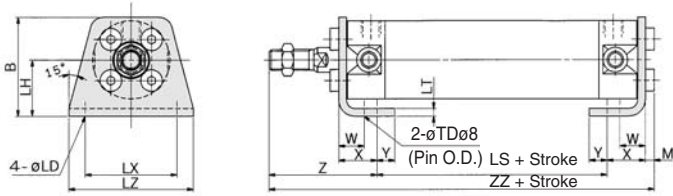

Axial Foot Style

Bore (mm)	B	LC	LD	LH	LS	LT	LX	LZ	M	W	X	Y	Z	
													Without rod boot	With rod boot
20	34	4	6	20	53	3	32	44	3	10	15	7	47	118
25	38.5	4	6	22	53	3	36	49	3.5	10	15	7	52	123.5
32	45	4	7	25	53	3	44	58	3.5	10	16	8	53	125.5
40	54.5	4	7	30	60	3	54	71	4	10	16.5	8.5	63.5	144
50	70.5	5	10	40	67	4.5	66	86	5	17.5	22	11	75.5	169.5
63	82.5	5	12	45	67	4.5	82	106	5	17.5	22	13	75.5	169.5
80	101	6	11	55	74	4.5	100	125	5	20	28.5	14	95	202.5
100	121	6	14	65	74	6	120	150	7	20	30	16	95	206

* Other dimensions are the same as basic style.

Rod side flange style: CG1FQ

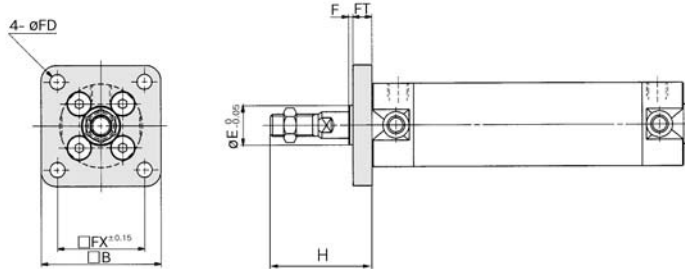

Flange Style

Bore (mm)	Stroke range		B	E	F	FX	FD	FT	H	Head side flange ZZ	
	Rod side	Head side								Without rod boot	With rod boot
20	Up to 350	Up to 200	40	12	2	28	5.5	6	35	120	
25	Up to 400	Up to 300	44	14	2	32	5.5	7	40	126	
32	Up to 450	Up to 300	53	18	2	38	6.6	7	40	128	
40	Up to 500	Up to 500	61	25	2	46	6.6	8	50	147	
50	Up to 1000	Up to 600	76	30	2	58	9	9	58	171	
63	Up to 1000	Up to 600	92	32	2	70	11	9	58	171	
80	Up to 1000	Up to 750	104	40	3	82	11	11	71	207	
100	Up to 1000	Up to 750	128	50	3	100	14	14	71	210	

Note) End boss is machined on the flange for øE.

* Other dimensions are the same as basic style.

Head side flange style: CG1GQ

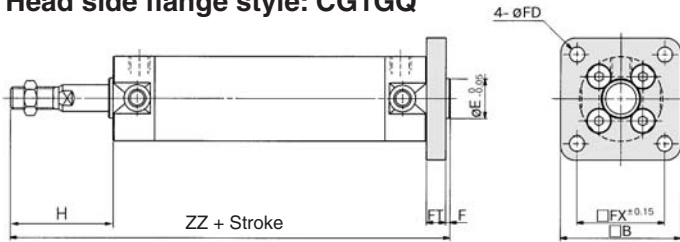

Rod side trunnion style: CG1UQ

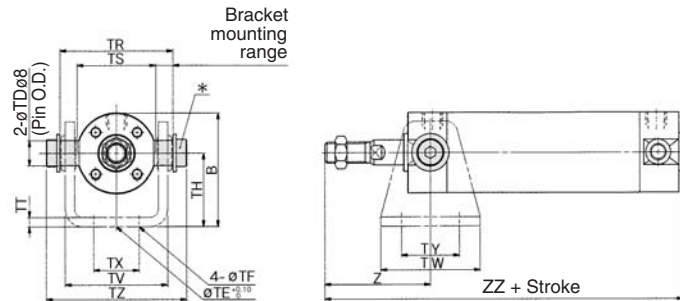

Trunnion Style

Bore (mm)	Stroke range		B	TDe8	TE	TF	TH	TR	TS	TT	TV
	Rod side	Head side									
20	Up to 200	Up to 200	38	8 ^{-0.025/-0.047}	10	5.5	25	39	28	3.2	(35.8)
25	Up to 300	Up to 300	45.5	10 ^{-0.025/-0.047}	10	5.5	30	43	33	3.2	(39.8)
32	Up to 300	Up to 300	54	12 ^{-0.032/-0.059}	10	6.6	35	54.5	40	4.5	(49.4)
40	Up to 500	Up to 500	63.5	14 ^{-0.032/-0.059}	10	6.6	40	65.5	49	4.5	(58.4)
50	Up to 600	Up to 600	79	16 ^{-0.032/-0.059}	20	9	50	80	60	6	(72.4)
63	Up to 600	Up to 600	96	18 ^{-0.032/-0.059}	20	11	60	98	74	8	(90.4)

Head side trunnion style: CG1TQ

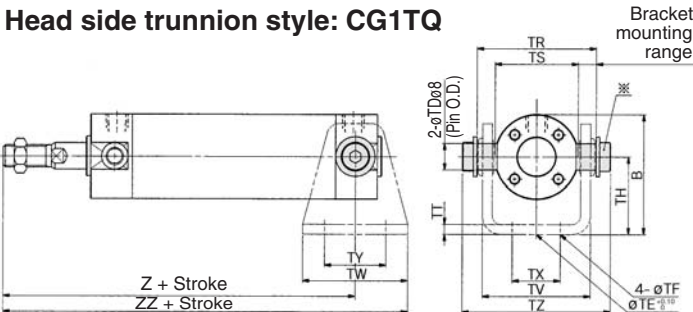

Bore (mm)	TW	TX	TY	TZ	Rod side		Head side	
					Z		ZZ	
					Without rod boot	With rod boot	Without rod boot	With rod boot
20	42	16	28	47.6	46	101	122	
25	42	20	28	53	51	106	127	
32	48	22	28	67.7	51	108	132	
40	56	30	30	78.7	62	125	153	
50	64	36	36	98.6	71	147	179	
63	74	46	46	119.2	71	147	184	

* Consists of pin, flat washer and hexagon socket head cap bolt.

Note) For pivot bracket, refer to Best Pneumatics.

* Other dimensions are the same as basic style.

With Mounting Bracket

Clevis style: CG1DQ

ø20 to ø63

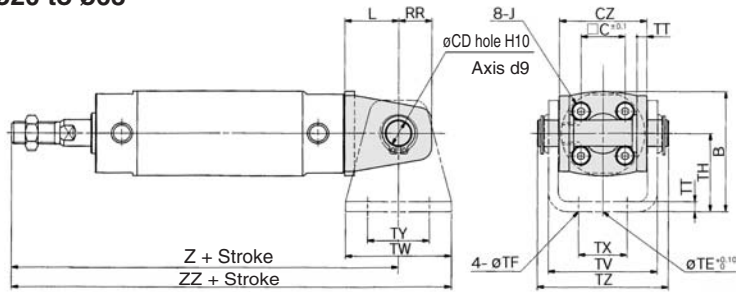

(The above shows the case port location is changed by 90°.)

ø80, ø100

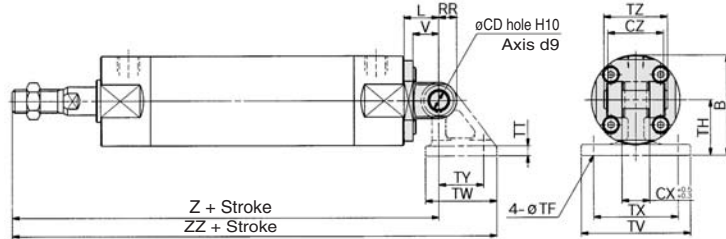

Clevis Style

Bore size (mm)	Stroke range (mm)	B	CD	CX	CZ	L	RR	V	TE	TF	TH
20	Up to 200	38	8	—	29	14	11	—	10	5.5	25
25	Up to 300	45.5	10	—	33	16	13	—	10	5.5	30
32	Up to 300	54	12	—	40	20	15	—	10	6.6	35
40	Up to 500	63.5	14	—	49	22	18	—	10	6.6	40
50	Up to 600	79	16	—	60	25	20	—	20	9	50
63	Up to 600	96	18	—	74	30	22	—	20	11	60
80	Up to 750	99.5	18	28	56	35	18	26	—	11	55
100	Up to 750	120	22	32	64	43	22	32	—	13.5	65

Bore size (mm)	TT	TV	TW	TX	TY	TZ	Z	ZZ	Applicable pin part no.
20	3.2	(35.8)	42	16	28	43.4	126	147	CD-G02
25	3.2	(39.8)	42	20	28	48	133	154	CD-G25
32	4.5	(49.4)	48	22	28	59.4	139	163	CD-G03
40	4.5	(58.4)	56	30	30	71.4	159	187	CD-G04
50	6	(72.4)	64	36	36	86	185	217	CD-G05
63	8	(90.4)	74	46	46	105.4	190	227	CD-G06
80	11	110	72	85	45	64	228	286.5	IY-G08
100	12	130	93	100	60	72	236	312.5	IY-G10

Note) * For pivot bracket, refer to Best Pneumatics.
 * Other dimensions are the same as basic style.

* Clevis pin and snap ring are shipped together with clevis type.

Air Cylinder: With End Lock

Series **CBG1**

ø20, ø25, ø32, ø40, ø50, ø63, ø80, ø100



How to Order

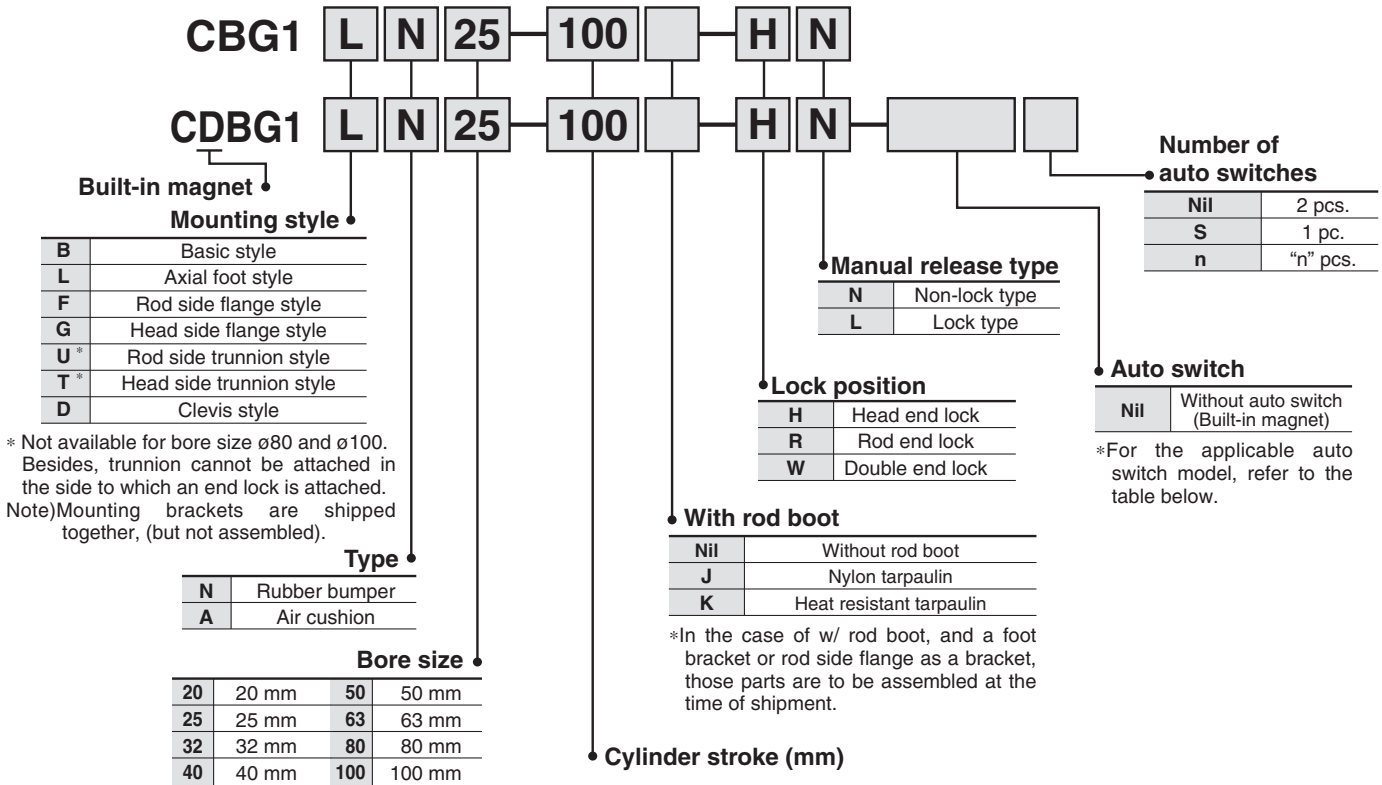

Applicable Auto Switch/Refer to Best Pneumatics for further information on auto switches.

Type	Special function	Electrical entry	Indicator/light	Wiring (Output)	Load voltage		Auto switch model		Lead wire length (m)*				Pre-wire connector	Applicable load		
					DC	AC	Applicable bore size (mm)		0.5 (Nil)	3 (L)	5 (Z)	None (N)		IC circuit	Relay, PLC	
Reed switch	—	Grommet	Yes	3-wire (NPN equivalent)	—	5 V	—	C76	—	●	●	—	—			—
										24 V	100 V, 200 V	B54		●	●	
	12 V	100 V	C73	—	●	●	●	—	—							
Diagnostic indication (2-color indication)	Grommet	Yes	2-wire	—	—	—	—	C73C		—	●	●	●	●	—	—
									B59W		●	●	—	—		
Solid state switch	—	Grommet	Yes	3-wire (NPN)	24 V	5 V, 12 V	—	M9N	G59	●	—	○	—	○	IC circuit	Relay, PLC
				3-wire (PNP)				M9P	G5P	●	—	○	—	○		
				2-wire				M9B	K59	●	—	○	—	○		
	Diagnostic indication (2-color indication)	Grommet	Yes	3-wire (NPN)	24 V	5 V, 12 V	—	M9NW	G59W	●	●	○	—	○	IC circuit	—
				3-wire (PNP)				M9PW	G5PW	●	●	○	—	○		
	Water resistant (2-color indication)	Grommet	Yes	2-wire	24 V	12 V	—	M9BW	K59W	●	●	○	—	○	—	—
				4-wire (NPN)				M9BA	G5BA	●	●	○	—	○		
Diagnostic output (2-color indication)	Grommet	Yes	4-wire (NPN)	24 V	5 V, 12 V	—	—	G59F	—	●	●	○	—	○	IC circuit	—

* Lead wire length symbols: 0.5 m Nil (Example) C73C M9NW * Solid state switches marked with "○" are produced upon receipt of order.
 3 m L (Example) C73CL M9NL • Since there are other applicable auto switches than listed, contact SMC for details.
 5 m Z (Example) C73CZ M9NZ • For details about auto switches with pre-wire connector, refer to Best Pneumatics.
 None N (Example) C73CN



Made to Order Specifications

Symbol	Specifications
-XA□	Change of rod end shape

Minimum Stroke for Auto Switch Mounting

Model	No. of auto switches mounted	
	2	1
D-C7/C8 D-B5/B6 D-M9 D-G5/K5	15 mm	10 mm
D-B59W	20 mm	15 mm
D-H7LF	20 mm	10 mm

Rod Boot Material

Symbol	Rod boot material	Maximum operating temperature
J	Nylon tarpaulin	70°C
K	Heat resistant tarpaulin	110°C *

*Maximum ambient temperature for the rod boot itself.

Specifications

Bore size (mm)	20	25	32	40	50	63	80	100
Action	Double acting, Single rod							
Type	Non-lube							
Fluid	Air							
Proof pressure	1.5 MPa							
Maximum operating pressure	1.0 MPa							
Minimum operating pressure	0.15 MPa *							
Ambient and fluid temperature	Without auto switch: -10 to 70°C (No freezing) With auto switch: -10 to 60°C (No freezing)							
Piston speed	50 to 1000 mm/s						50 to 700 mm/s	
Stroke length tolerance	Up to 1000 ^{st+1.4} ₀ mm, Up to 1200 ^{st+1.8} ₀ mm						Up to 1000 ^{st+1.4} ₀ mm Up to 1500 ^{st+1.8} ₀ mm	
Thread tolerance	JIS Class 2							
Cushion	Rubber bumper, Air cushion							
Mounting **	Basic style, Axial foot style, Rod side flange style Head side flange style, Rod side trunnion style Head side trunnion style, Clevis style (Used for changing the port location by 90°.)							



* 0.05 MPa except locking parts.

** Rod/Head side trunnion styles are not available for bore sizes ø80 and ø100.
Trunnion is not attached for a cover on which lock mechanism is equipped.

Lock Specifications

Lock position	Head end, Rod end, Double end							
Holding force (Max.) (N)	ø20	ø25	ø32	ø40	ø50	ø63	ø80	ø100
	215	330	550	860	1340	2140	3450	5390
Backlash	2 mm or less							
Manual release	Non-lock type, Lock type							

Adjust the switch position so that it operates upon movement to both the stroke end and backlash (2 mm) positions.

Standard Stroke

Bore size (mm)	Standard stroke (mm) ⁽¹⁾	Long stroke (mm)	Maximum manufacturable stroke (mm)
20	25, 50, 75, 100, 125, 150, 200	201 to 350	1500
25	25, 50, 75, 100, 125, 150, 200, 250, 300	301 to 400	
32		301 to 450	
40		301 to 800	
50, 63		301 to 1200	
80		301 to 1400	
100		301 to 1500	



Note1) Intermediate strokes other than the above are produced upon receipt of order. Spacers are not used for intermediate strokes.

Note2) Long stroke applies to the axial foot style and the rod side flange style.

If other mounting brackets are used, or the length exceeds the long stroke limit, the stroke should be determined based on the stroke selection table in the technical data.

⚠ Precautions

Be sure to read before handling. For Safety Instructions and Actuator Precautions, refer to Best Pneumatics.

Use the Recommended Pneumatic Circuit

⚠ Caution

- This is necessary for proper operation and release of the lock.

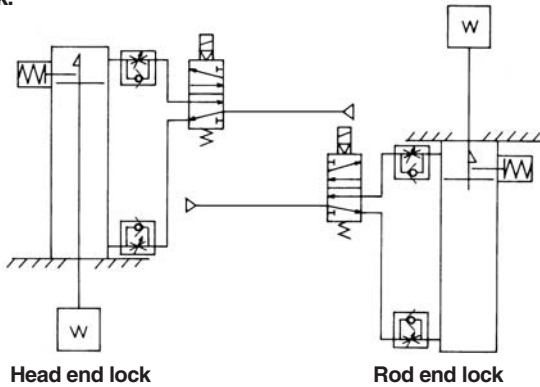

Operating Precautions

⚠ Caution

- Do not use 3 position solenoid valves.**
Avoid use in combination with 3 position solenoid valves (especially closed center metal seal types). If pressure is trapped in the port on the lock mechanism side, the cylinder cannot be locked. Furthermore, even after being locked, the lock may be released after some time, due to air leaking from the solenoid valve and entering the cylinder.
- Back pressure is required when releasing the lock.**
Be sure air is supplied to side of cylinder without the locking mechanism, as above, prior to supplying air pressure to the side with end lock or lock may not be released. (Refer to "Releasing the Lock".)
- Release the lock when mounting or adjusting the cylinder.**
If mounting or other work is performed when the cylinder is locked, the lock unit may be damaged.
- Operate with a load ratio of 50% or less.**
If the load ratio exceeds 50%, this may cause problems such as failure of the lock to release, or damage to the lock unit.
- Do not operate multiple cylinders in synchronization.**
Avoid applications in which two or more end lock cylinders are synchronized to move one workpiece, as one of the cylinder locks may not be able to release when required.
- Use a speed controller with meter-out control.**
Lock cannot be released occasionally by meter-in control.
- Be sure to operate completely to the cylinder stroke end on the side with the lock.**
If the cylinder piston does not reach the end of the stroke, locking and unlocking may not be possible.
- Do not use an air cylinder as an air-hydro cylinder. This could result in leakage of oil.**
- Install a rod boot without twisting.**
If the cylinder is installed with its bellows twisted, it could damage the bellows.
- Adjust an auto switch position so that it operates for movement to both the stroke end and backlash (2 mm) positions.**
When a 2-color indication switch is adjusted for green indication at the stroke end, it may change to red for the backlash return, but this is not abnormal.

Operating Precautions

⚠ Warning

- Do not operate the cushion valve in the fully closed or fully opened state.**
Using it in the fully closed state will cause the cushion seal to be damaged. Using it in the fully opened state will cause the piston rod assembly or the cover to be damaged.
- Operate within the specified cylinder speed.**
Otherwise, cylinder and seal damage may occur.

Operating Pressure

⚠ Caution

- Use pressures over 0.15 MPa at port with locking mechanism.

Exhaust Speed

⚠ Caution

- Locking will occur automatically if the pressure applied to the port on the lock mechanism side falls to 0.05 MPa or less. In cases where the piping on the lock mechanism side is long and thin, or the speed controller is separated at some distance from the cylinder port, the exhaust speed will be reduced. Take note that some time may be required for the lock to engage. In addition, clogging of a silencer mounted on the solenoid valve exhaust port can produce the same effect.

Relation to Cushion

⚠ Caution

- When cushion valve at side with locking mechanism is fully opened or closed, piston rod may reached at stroke end. Thus lock is not established. And when locking is done at cushion valve fully closed, adjust cushion valve since lock may not be released.

Releasing the Lock

⚠ Warning

- Before releasing the lock, be sure to supply air to the side without the lock mechanism, so that there is no load applied to the lock mechanism when it is released. (Refer to the recommended pneumatic circuits.) If the lock is released when the port on the other side is in an exhaust state, and with a load applied to the lock unit, the lock unit may be subjected to an excessive force and be damaged. Furthermore, sudden movement of the piston rod is very dangerous.

Disassembly/Replacement

⚠ Caution

- Do not replace the bushings or the cushion seals.**
The bushings and the cushion seals are press-fit. To replace them, they must be replaced together with the cover assembly.
- To replace a seal, apply grease to the new seal before installing it.**
If the cylinder is put into operation without applying grease to the seal, it could cause the seal to wear significantly, leading to premature air leakage.
- Those with a bore of $\phi 50$ or more cannot be disassembled.**
When disassembling cylinders with bore sizes of $\phi 20$ through $\phi 40$, grip the double flat part of either the head cover or the rod cover with a vise and loosen the other side with a wrench or a monkey wrench, etc., and then remove the cover. When re-tightening, tighten approximately 2 degrees more than the original position. (Cylinders with $\phi 50$ or larger bore sizes are tightened with a large tightening torque and cannot be disassembled. Please contact SMC when disassembly is required.)

Construction: With Rubber Bumper

Head end lock

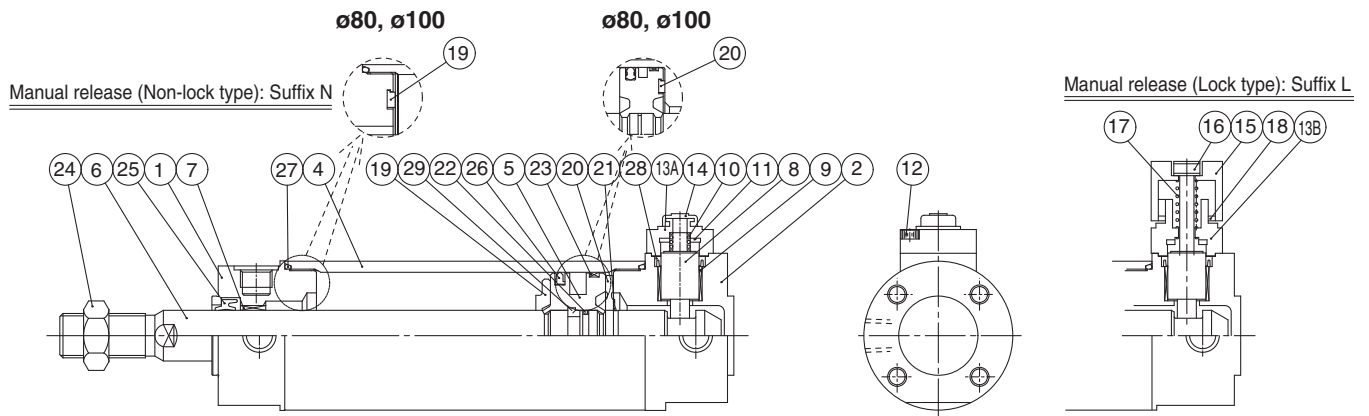

Rod end lock

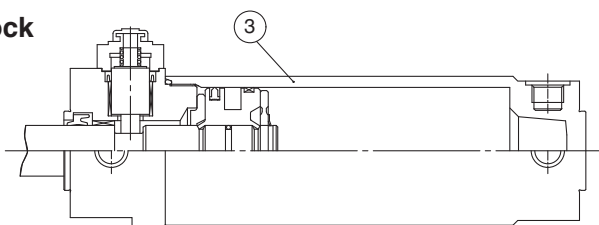

Long stroke

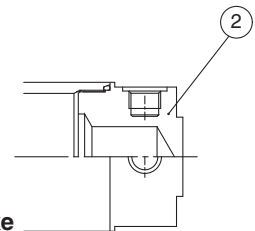

Component Parts

No.	Description	Material	Note
①	Rod cover	Aluminum alloy	Clear hard anodized
②	Head cover	Aluminum alloy	Clear hard anodized
③	Tube cover	Aluminum alloy	Clear hard anodized
④	Cylinder tube	Aluminum alloy	Hard anodized
⑤	Piston	Aluminum alloy	Chromated
⑥	Piston rod	Carbon steel *	Hard chrome plated
⑦	Bushing	Oil-impregnated sintered alloy	ø40 and larger are lead-bronze casted
⑧	Lock piston	Carbon steel	Hard chrome plated, Heat treated
⑨	Lock bushing	Copper alloy	
⑩	Lock spring	Stainless steel	
⑪	Bumper	Urethane	
⑫	Hexagon socket head cap screw	Alloy steel	Black zinc chromated
⑬	Cap A	Aluminum die-casted	Black painted
⑭	Cap B	Carbon steel	Oxide film treated
⑮	Rubber cap	Synthetic rubber	
⑯	M/O knob	Zinc die-casted	Black painted
⑰	M/O bolt	Alloy steel	Black zinc chromated, Red painted
⑱	M/O spring	Steel wire	Zinc chromated
⑲	Stopper ring	Carbon steel	Zinc chromated
⑳	Bumper A	Urethane	
㉑	Bumper B	Urethane	ø40 or larger: the same as bumper A

Note) In the case of cylinders with auto switches, magnets are installed in the piston.

* The material is stainless steel on auto switch equipped styles ø20 and ø25.

No.	Description	Material	Note
①	Snap ring	Stainless steel	None for ø80, ø100
②	Piston gasket	NBR	
③	Wear ring	Resin	
④	Rod end nut	Rolled steel	Nickel plated
⑤	Rod seal	NBR	
⑥	Piston seal	NBR	
⑦	Cylinder tube gasket	NBR	1 pc. when using tube cover
⑧	Lock piston seal	NBR	2 pcs. for with locks in both sides
⑨	Piston holder	Urethane	ø40 to ø100 only

Replacement Parts: Seal Kit (With lock at single end)

Series	Bore size (mm)	Kit no.	Contents
CBG1□N Rubber bumper type	20	CBG1N20-PS	Set of nos. above ①, ②, ③, ④ and grease pack
	25	CBG1N25-PS	
	32	CBG1N32-PS	
	40	CBG1N40-PS	
	50	CBG1N50-PS	
	63	CBG1N63-PS	
	80	CBG1N80-PS	
100	CBG1N100-PS		

Order seal kit in accordance with the bore size.

Replacement Parts: Seal Kit (With lock at double end)

Series	Bore size (mm)	Kit no.	Contents
CBG1□N Rubber bumper type	20	CBG1N20-PS-W	Set of nos. above ②⑤, ②⑥, ②⑦, ②⑧ and grease pack
	25	CBG1N25-PS-W	
	32	CBG1N32-PS-W	
	40	CBG1N40-PS-W	
	50	CBG1N50-PS-W	
	63	CBG1N63-PS-W	
	80	CBG1N80-PS-W	
100	CBG1N100-PS-W		

Order seal kit in accordance with the bore size.

Series CBG1

Construction: With Air Cushion

With air cushion Head end lock

Manual release (Non-lock type): Suffix N

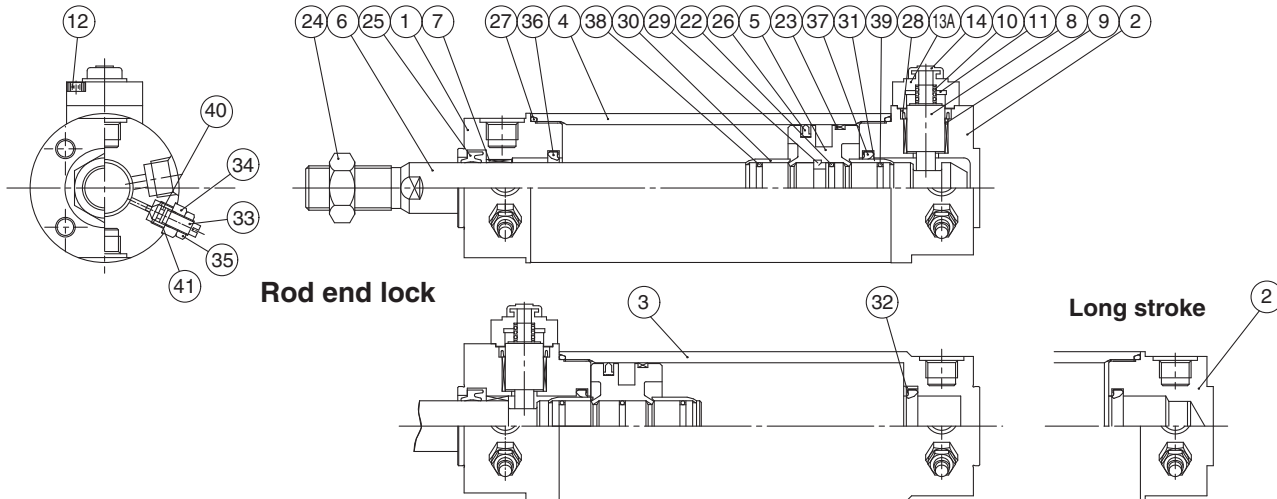

Component Parts

No.	Description	Material	Note
①	Rod cover	Aluminum alloy	Clear hard anodized
②	Head cover	Aluminum alloy	Clear hard anodized
③	Tube cover	Aluminum alloy	Clear hard anodized
④	Cylinder tube	Aluminum alloy	Hard anodized
⑤	Piston	Aluminum alloy	Chromated
⑥	Piston rod	Carbon steel *	Hard chrome plated
⑦	Bushing	Oil-impregnated sintered alloy	ø40 and larger are lead-bronze casted
⑧	Lock piston	Carbon steel	Hard chrome plated, Heat treated
⑨	Lock bushing	Copper alloy	
⑩	Lock spring	Stainless steel	
⑪	Bumper	Urethane	
⑫	Hexagon socket head cap screw	Alloy steel	Black zinc chromated
⑬A	Cap A	Aluminum die-casted	Black painted
⑬B	Cap B	Carbon steel	Oxide film treated
⑭	Rubber cap	Synthetic rubber	
⑮	M/O knob	Zinc die-casted	Black painted
⑯	M/O bolt	Alloy steel	Black zinc chromated, Red painted
⑰	M/O spring	Steel wire	Zinc chromated
⑱	Stopper ring	Carbon steel	Zinc chromated

Note) In the case of cylinders with auto switches, magnets are installed in the piston.
* The material is stainless steel on auto switch equipped styles ø20 and ø25.

No.	Description	Material	Note
⊙	Piston gasket	NBR	
⊙	Wear ring	Resin	
⊙	Rod end nut	Rolled steel	Nickel plated
⊙	Rod seal	NBR	1 pc. when using tube cover
⊙	Piston seal	NBR	2 pcs. for with locks in both sides
⊙	Cylinder tube gasket	NBR	
⊙	Lock piston seal	NBR	
⊙	Piston holder	Urethane	ø40 to ø100 only
⊙	Cushion ring A	Brass	
⊙	Cushion ring B	Brass	Only when using nickel plated, tube cover
⊙	Seal retainer	Rolled steel	
⊙	Cushion valve	Rolled steel	Electroless nickel plated
⊙	Valve retainer	Rolled steel	Electroless nickel plated
⊙	Lock nut	Rolled steel	Nickel plated
⊙	Cushion seal A	Urethane	
⊙	Cushion seal B	Urethane	ø32 or larger: The same as A
⊙	Cushion ring gasket A	NBR	
⊙	Cushion ring gasket B	NBR	ø32 or larger: The same as A
⊙	Valve seal	NBR	
⊙	Valve retaining gasket	NBR	

Replacement Parts: Seal Kit (With lock at single end)

Series	Bore size (mm)	Kit no.	Contents
CBG1□A Rubber bumper type	20	CBG1A20-PS	Set of nos. above ⑳, ㉑, ㉒, ㉓, ㉔ and grease pack
	25	CBG1A25-PS	
	32	CBG1A32-PS	
	40	CBG1A40-PS	
	50	CBG1A50-PS	
	63	CBG1A63-PS	
	80	CBG1A80-PS	
100	CBG1A100-PS		

Order seal kit in accordance with the bore size.

Replacement Parts: Seal Kit (With lock at double end)

Series	Bore size (mm)	Kit no.	Contents
CBG1□A Rubber bumper type	20	CBG1A20-PS-W	Set of nos. above ⑳, ㉑, ㉒, ㉓, ㉔ and grease pack
	25	CBG1A25-PS-W	
	32	CBG1A32-PS-W	
	40	CBG1A40-PS-W	
	50	CBG1A50-PS-W	
	63	CBG1A63-PS-W	
	80	CBG1A80-PS-W	
100	CBG1A100-PS-W		

Order seal kit in accordance with the bore size.

Rubber Bumper Type: CBG1BN

Head end lock: CBG1BN **Bore size** — **Stroke** — H□

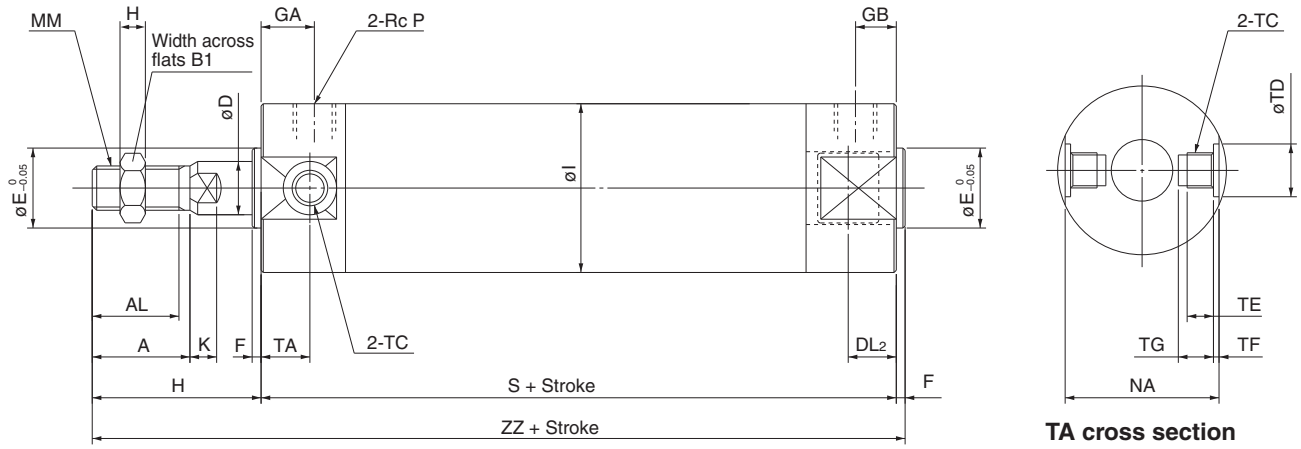

Manual release (Non-lock type): Suffix N

Manual release (Lock type): Suffix L

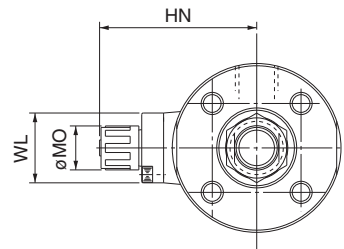
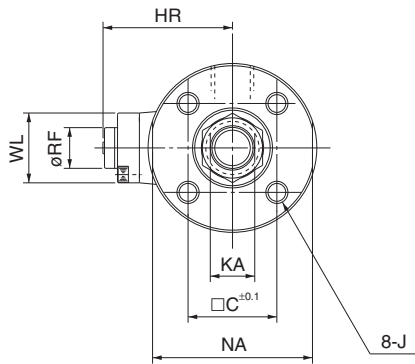

Bore size (mm)	Stroke range	A	AL	B ₁	C	D	DL ₂	E	F	GA	GB	H	H ₁	HR	HN (Max.)	I	J
20	Up to 350	18	15.5	13	14	8	12.5	12	2	12	12	35	5	25.3	37	26	M4 x 0.7 depth 7
25	Up to 400	22	19.5	17	16.5	10	12.5	14	2	12	12	40	6	28.3	40	31	M5 x 0.8 depth 7.5
32	Up to 450	22	19.5	17	20	12	12	18	2	12	12	40	6	31.3	43	38	M5 x 0.8 depth 8
40	Up to 800	30	27	19	26	16	15	25	2	13	13	50	8	38.3	52.5	47	M6 x 1 depth 12
50	Up to 1200	35	32	27	32	20	16.5	30	2	14	14	58	11	44.5	58.5	58	M8 x 1.25 depth 16
63	Up to 1200	35	32	27	38	20	16.5	32	2	14	14	58	11	45	59	72	M10 x 1.5 depth 16
80	Up to 1400	40	37	32	50	25	19	40	3	20	20	71	13	53.5	68	89	M10 x 1.5 depth 22
100	Up to 1500	40	37	41	60	30	20	50	3	20	20	71	16	64.5	79	110	M12 x 1.75 depth 22

Bore size (mm)	K	KA	MM	MO	NA	P	RF	S	TA	TC	TDH ₉	TE	TF	TG	WL	ZZ
20	5	6	M8 x 1.25	15	24	1/8	11	81	11	M5 x 0.8	8 ^{+0.08} ₀	4	0.5	5.5	15	118
25	5.5	8	M10 x 1.25	15	29	1/8	11	81	11	M6 x 0.75	10 ^{+0.08} ₀	5	1	6.5	15	123
32	5.5	10	M10 x 1.25	15	35.5	1/8	11	81	11	M8 x 1.0	12 ^{+0.08} ₀	5.5	1	7.5	24	123
40	6	14	M14 x 1.5	19	44	1/8	11	92	12	M10 x 1.25	14 ^{+0.08} ₀	6	1.25	8.5	24	144
50	7	18	M18 x 1.5	19	55	1/4	11	107	13	M12 x 1.25	16 ^{+0.08} ₀	7.5	2	10	24	167
63	7	18	M18 x 1.5	19	69	1/4	11	107	13	M14 x 1.5	18 ^{+0.08} ₀	11.5	3	14.5	24	167
80	10	22	M22 x 1.5	23	80	3/8	21	130	—	—	—	—	—	—	40	204
100	10	26	M26 x 1.5	23	100	1/2	21	130	—	—	—	—	—	—	40	204

Series CBG1

Rubber Bumper Type: CBG1BN

Rod end lock: CBG1BN **Bore size** — **Stroke** — R□

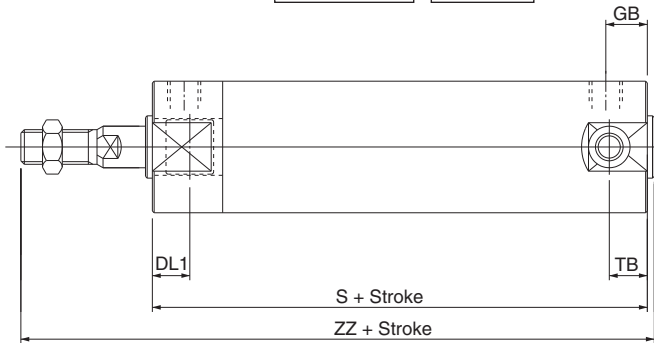

Bore size (mm)	DL1	GB	S	TB	ZZ
20	19.5	10(12)	80(88)	11	117(125)
25	19.5	10(12)	80(88)	11	122(130)
32	20	10(12)	81(89)	10(11)	123(131)
40	19	10(13)	87(96)	10(12)	139(148)
50	23.5	12(14)	102(114)	12(13)	162(174)
63	23.5	12(14)	102(114)	12(13)	162(174)
80	27	16(20)	124(138)	—	198(212)
100	30	16(20)	124(138)	—	198(212)

* (): Denotes the dimensions for long stroke.

Double end lock: CBG1BN **Bore size** — **Stroke** — W□

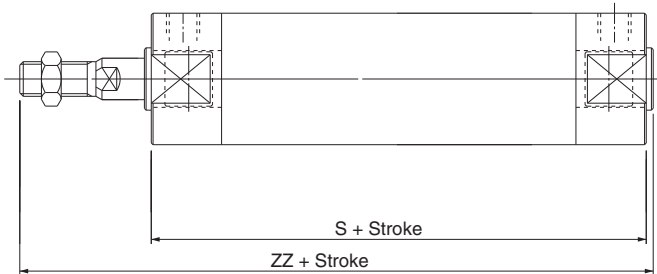

Bore size (mm)	S	ZZ
20	92	129
25	92	134
32	91	133
40	101	153
50	119	179
63	119	179
80	146	220
100	146	220

With rod boot

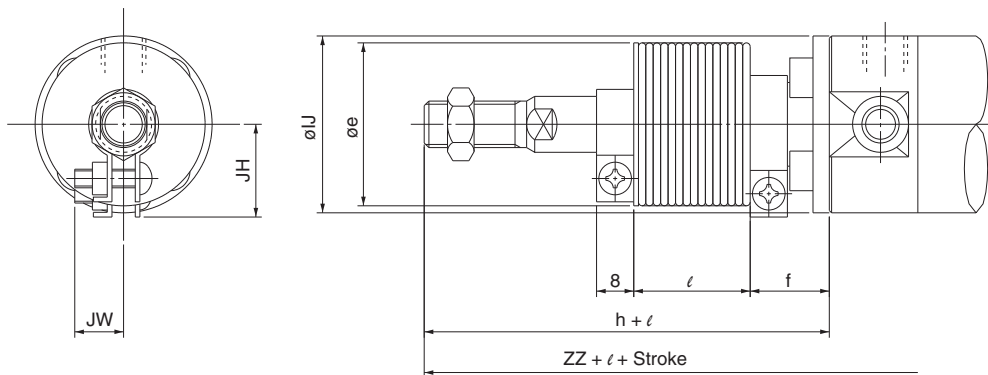

Bore size (mm)	e	f	h	IJ	JH	JW	l	Head end lock (-H□)	Rod end lock (-R□)	Double end lock (-W□)
								ZZ	ZZ	ZZ
20	30	16	55	27	(14.5)	(11.5)	0.25 stroke	138	137(145)	149
25	30	17	62	32	(17.5)	(11.5)		145	144(152)	156
32	35	17	62	38	(19.5)	(11.5)		145	145(153)	155
40	35	17	70	48	(22.5)	(13)		164	159(168)	173
50	40	17	78	59	(25)	(13)		187	182(194)	199
63	40	18	78	72	(25)	(13)		187	182(194)	199
80	52	10	80	59	—	—		213	207(221)	229
100	62	7	80	71	—	—		213	207(221)	229

* (): Denotes the dimensions for long strokes.

** The minimum stroke with rod boot is 20 mm.

Air Cushion Type: CBG1BA

Head end lock: CBG1BA Bore size Stroke - H

Rod end lock: CBG1BA Bore size Stroke - R

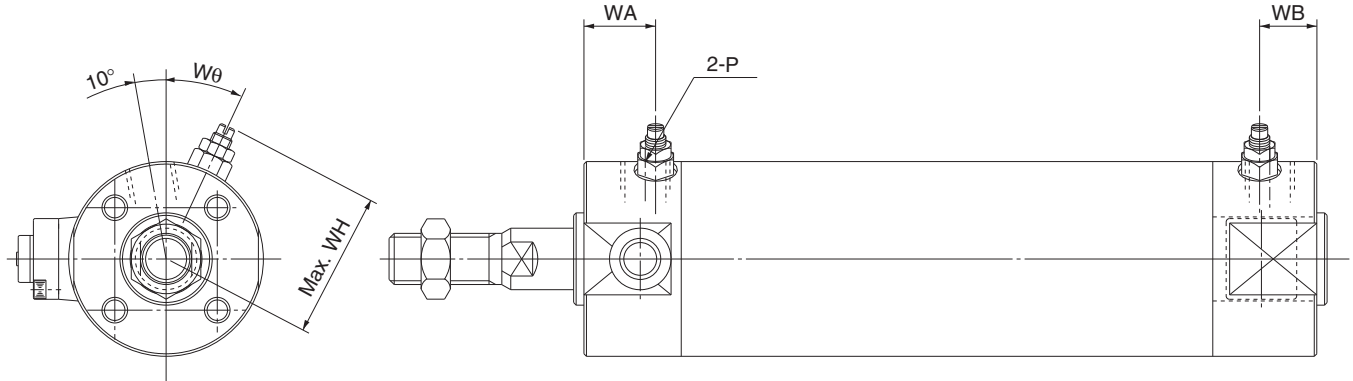

Head End Lock: -H

Bore size (mm)	P	WA	WB	WH	Wθ
20	M5 x 0.8	16	16	23	30°
25	M5 x 0.8	16	16	25	30°
32	Rc 1/8	16	16	28.5	25°
40	Rc 1/8	16	16	33	20°
50	Rc 1/4	18	18	40.5	20°
63	Rc 1/4	18	18	47.5	20°
80	Rc 3/8	22	22	60.5	20°
100	Rc 1/2	22	22	71	20°

* For dimensions other than listed above, refer to the dimensions with rubber bumper.

Rod End Lock: -R

Bore size (mm)	P	WA	WB	WH	Wθ
20	M5 x 0.8	16	15(16)	23	30°
25	M5 x 0.8	16	15(16)	25	30°
32	Rc 1/8	16	15(16)	28.5	25°
40	Rc 1/8	16	15(16)	33	20°
50	Rc 1/4	18	17(18)	40.5	20°
63	Rc 1/4	18	17(18)	47.5	20°
80	Rc 3/8	22	22	60.5	20°
100	Rc 1/2	22	22	71	20°

* (): Denotes the dimensions for long strokes.

** For dimensions other than the listed above, refer to the dimensions with rubber bumper.

Series CBG1

With Mounting Bracket

Axial foot style: CBG1LI

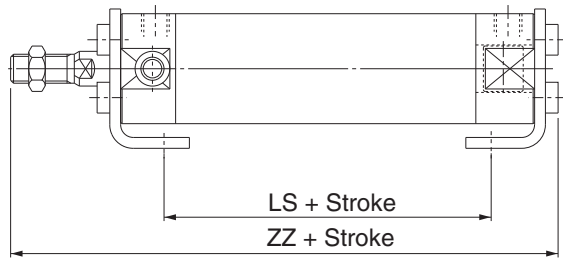

Rod side flange style: CBG1F□

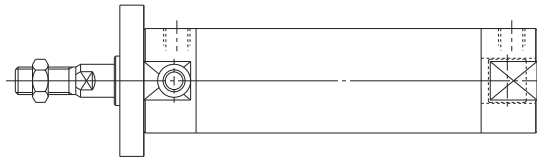

Head side flange style: CBG1G□

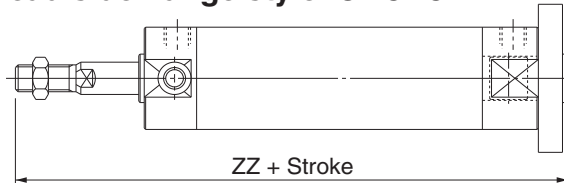

Foot Style

Bore size (mm)	Head end lock: -H□			Rod end lock: -R□			Double end lock: -W□		
	LS	ZZ		LS	ZZ		LS	ZZ	
	—	Without rod boot	With rod boot	—	Without rod boot	With rod boot	—	Without rod boot	With rod boot
20	57	122	142 + ℓ	56(64)	121(129)	141(149) + ℓ	68	133	153 + ℓ
25	57	127.5	149.5 + ℓ	56(64)	126.5(134.5)	148.5(156.5) + ℓ	68	138.5	160.5 + ℓ
32	55	127.5	149.5 + ℓ	55(63)	127.5(135.5)	149.5(157.5) + ℓ	65	137.5	159.5 + ℓ
40	65	149	169 + ℓ	60(69)	144(153)	164(173) + ℓ	74	158	178 + ℓ
50	72	174.5	194.5 + ℓ	67(79)	169.5(181.5)	189.5(201.5) + ℓ	84	186.5	206.5 + ℓ
63	72	174.5	194.5 + ℓ	67(79)	169.5(181.5)	189.5(201.5) + ℓ	84	186.5	206.5 + ℓ
80	82	210.5	219.5 + ℓ	76(90)	204.5(218.5)	213.5(227.5) + ℓ	98	226.5	235.5 + ℓ
100	82	214	223 + ℓ	76(90)	208(222)	217(231) + ℓ	98	230	239 + ℓ

* (): Denotes the dimensions for long stroke.

Rod Side Flange Style Overall length is the same as basic style.

Head Side Flange Style

Bore size (mm)	Head end lock: -H□		Rod end lock/-R□		Double end lock/-W□	
	ZZ (Head side flange)					
	Without rod boot	With rod boot	Without rod boot	With rod boot	Without rod boot	With rod boot
20	124	144 + ℓ	123	143 + ℓ	135	155 + ℓ
25	130	152 + ℓ	129	151 + ℓ	141	163 + ℓ
32	130	152 + ℓ	130	152 + ℓ	140	162 + ℓ
40	152	172 + ℓ	147(156)	167(176) + ℓ	161	181 + ℓ
50	176	196 + ℓ	171(183)	191(203) + ℓ	188	208 + ℓ
63	176	196 + ℓ	171(183)	191(203) + ℓ	188	208 + ℓ
80	215	224 + ℓ	209(223)	218(232) + ℓ	231	240 + ℓ
100	218	227 + ℓ	212(226)	221(235) + ℓ	234	243 + ℓ

* (): Denotes the dimensions for long stroke.

Rod side trunnion style: CBG1U□ (Rod end lock-H□ only)

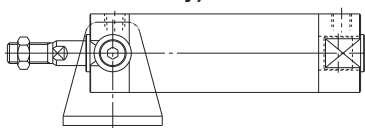

Head side trunnion style: CBG1T□ (Rod end lock -R□ only)

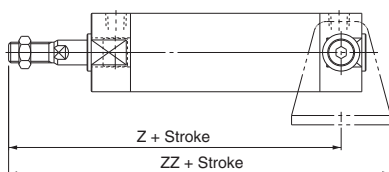

Rod Side Trunnion Style Overall length is the same as basic style.

Head Side Trunnion Style

Bore size (mm)	Rod end lock/-R□			
	Z (Head side trunnion)		ZZ (Head side trunnion)	
	Without rod boot	With rod boot	Without rod boot	With rod boot
20	104	124 + ℓ	125	145 + ℓ
25	109	131 + ℓ	130	152 + ℓ
32	111	133 + ℓ	135	157 + ℓ
40	127(134)	147(154) + ℓ	155(162)	175(182) + ℓ
50	148(159)	168(179) + ℓ	180(191)	200(211) + ℓ
63	148(159)	168(179) + ℓ	185(196)	205(216) + ℓ

* (): Denotes the dimensions for long stroke.

With Mounting Bracket

Clevis style: CBG1D□
ø20 to ø63

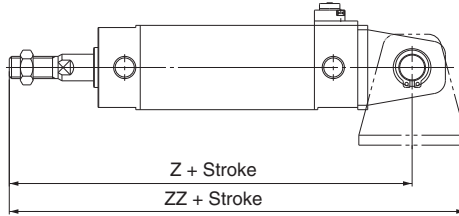

Clevis style: CBG1D□
ø80 to ø100

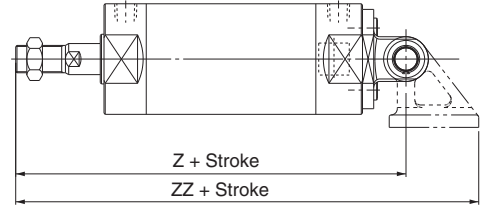

Clevis Style

Bore size (mm)	Head end lock: -H□				Rod end lock: -R□			
	Z		ZZ		Z		ZZ	
	Without rod boot	With rod boot	Without rod boot	With rod boot	Without rod boot	With rod boot	Without rod boot	With rod boot
20	130	150 + ℓ	151	171 + ℓ	129	149 + ℓ	150	170 + ℓ
25	137	159 + ℓ	158	180 + ℓ	136	158 + ℓ	157	179 + ℓ
32	141	163 + ℓ	165	187 + ℓ	141	163 + ℓ	165	187 + ℓ
40	164	184 + ℓ	192	212 + ℓ	159(168)	179(188) + ℓ	187(196)	207(216) + ℓ
50	190	210 + ℓ	222	242 + ℓ	185(197)	205(217) + ℓ	217(229)	237(249) + ℓ
63	195	215 + ℓ	232	252 + ℓ	190(202)	210(222) + ℓ	227(239)	247(259) + ℓ
80	236	245 + ℓ	294.5	303.5 + ℓ	230(244)	239(253) + ℓ	288.5(302.5)	297.5(311.5) + ℓ
100	244	253 + ℓ	320.5	329.5 + ℓ	238(252)	247(261) + ℓ	314.5(328.5)	323.5(337.5) + ℓ

Bore size (mm)	Double end lock/-W□			
	Z		ZZ	
	Without rod boot	With rod boot	Without rod boot	With rod boot
20	141	161 + ℓ	162	182 + ℓ
25	148	170 + ℓ	169	191 + ℓ
32	151	173 + ℓ	175	197 + ℓ
40	173	193 + ℓ	201	221 + ℓ
50	202	222 + ℓ	234	254 + ℓ
63	207	227 + ℓ	244	264 + ℓ
80	252	261 + ℓ	310.5	319.5 + ℓ
100	260	269 + ℓ	336.5	345.5 + ℓ

* (): Denotes the dimensions for long stroke.

Other than the applicable auto switches listed in “How to Order”, the following auto switches can be mounted. For detailed specifications, refer to Best Pneumatics.

Type	Model	Electrical entry	Features	Applicable bore size (mm)
Reed switch	D-C80	Grommet	Without indicator light	20 to 63
	D-C80C	Connector		
	D-B53	Grommet	—	20 to 100
	D-B64	Grommet	Without indicator light	
Solid state switch	D-G5NTL	Grommet	With timer	

* With pre-wire connector is available for D-G5NTL type, too. Refer to page Best Pneumatics for details.

* Wide range detection type, solid state auto switch (D-G5NBL type) is also available. For details, refer to Best Pneumatics.

SMC Auto Switch Variations

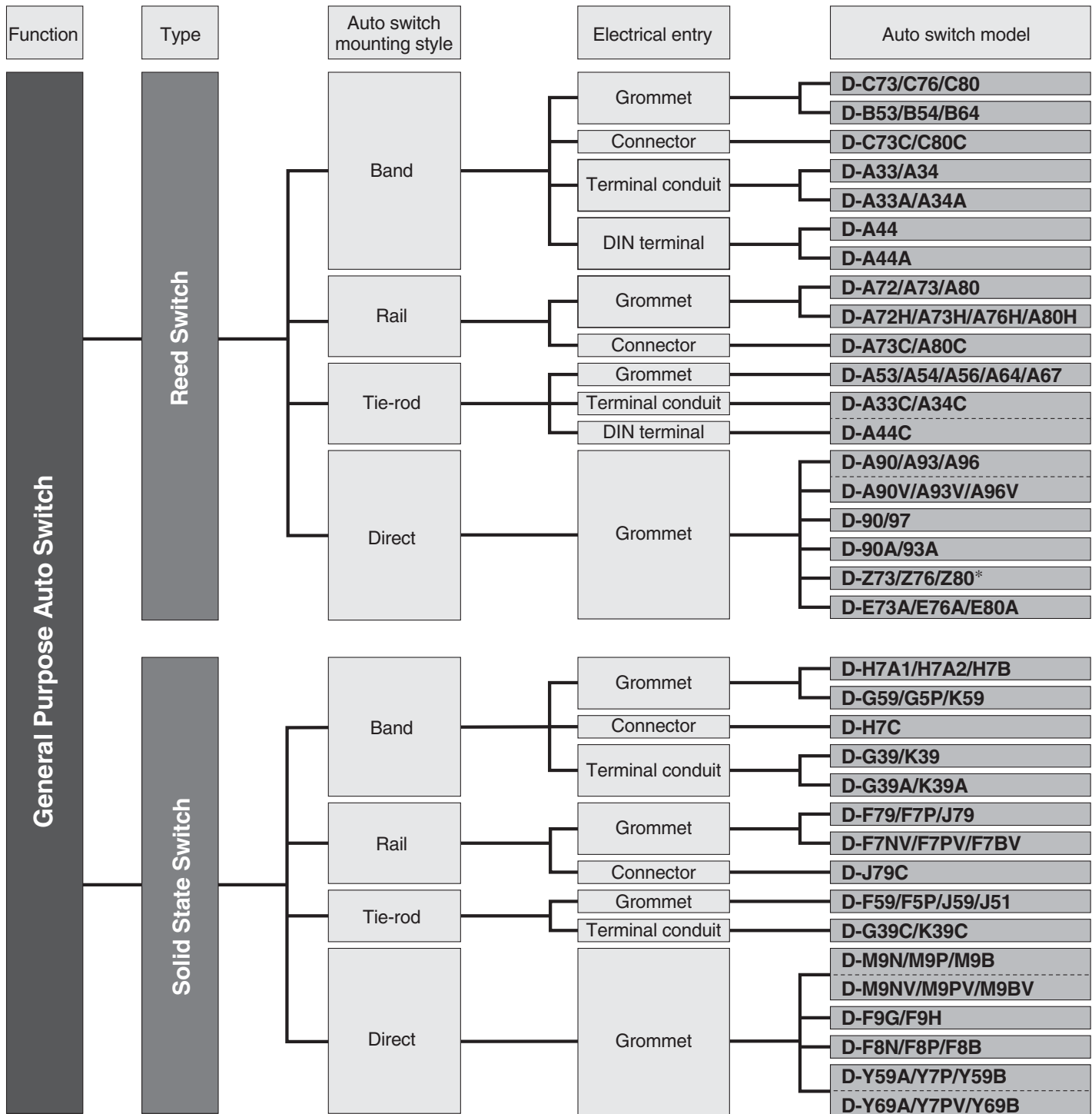

* This auto switch can be mounted by tie-rod with using mounting bracket. For details, refer to Best Pneumatics.

Function	Type	Auto switch mounting style	Electrical entry	Auto switch model
----------	------	----------------------------	------------------	-------------------

The optimum operating position can be determined by the color of the light. (Red → Green ← Red)

2-color indication	Reed switch	Band	Grommet	D-B59W
		Rail	Grommet	D-A79W
		Tie-rod	Grommet	D-A59W
	Solid state switch	Band	Grommet	D-H7NW/H7PW/H7BW
		Rail		D-G59W/G5PW/K59W
		Tie-rod	D-F79W/F7PW/J79W	
		Direct	Grommet	D-F7NWW/F7BWV
				D-F59W/F5PW/J59W
				D-F9NW/F9PW/F9BW
				D-F9NWW/F9PWW/F9BWW
			D-Y7NW/Y7PW/Y7BW*	
			D-Y7NWW/Y7PWW/Y7BWW*	
			D-M5NW/M5PW/M5BW	

The output signal can be detected in an unsteady detecting area.

2-color indication with diagnostic output	Solid state switch	Band	Grommet	D-H7NF
		Rail	Grommet	D-G59F
		Tie-rod	Grommet	D-F79F
				D-F59F

Water (coolant) resistant type

Water resistant 2-color indication	Solid state switch	Band	Grommet	D-H7BAL
		Rail		D-G5BAL
		Tie-rod	Grommet	D-F7BAL
		Direct		D-F7BAVL
			Grommet	D-F5BAL
	Grommet	D-F9BAL		
				D-Y7BAL*

With built-in OFF-delay timer (200 ms)

With timer	Solid state switch	Band	Grommet	D-G5NTL
		Rail	Grommet	D-F7NTL
		Tie-rod	Grommet	D-F5NTL
		Direct	Grommet	D-M5NTL/M5PTL

Possible to use in an environment where disturbance magnetic fields are generated.

Magnetic field resistant	Solid state switch	Rail	Grommet	D-P5DWL
--------------------------	--------------------	------	---------	---------

General purpose auto switch

Band mounting



Rail mounting



Tie-rod mounting



Direct mounting



2-color indication



2-color indication with diagnostic output



Water resistant 2-color indication



With timer



Prior to Use.

Auto Switches Common Specifications

⚠ Precautions

Refer to "Auto Switches Precautions" in Best Pneumatics.

Auto Switches Common Specifications

Type	Reed switch	Solid state switch
Leakage current	None	3-wire: 100 μ A or less, 2-wire: 0.8 mA or less ⁽⁴⁾
Operating time	1.2 ms	1 ms or less ⁽³⁾
Impact resistance	300 m/s ²	1000 m/s ²
Insulation resistance	50 M Ω or more at 500 M VDC (Between lead wire and case)	
Withstand voltage	1500 VAC for 1 minute ⁽¹⁾ (Between lead wire and case)	1000 VAC for 1 minute (Between lead wire and case)
Ambient temperature	-10 to 60°C	
Enclosure	IEC529 Standard IP67, Immersible construction (JIS C 0920) ⁽²⁾	

Note 1) Electrical entry: Connector type (A73C/A80C/C73C/C80C) and D-9/9□A/A9/A9□V type: 1000 VAC/min. (Between lead wire and the case)

Note 2) The following switches, Terminal conduit type (D-A3/A3□A/A3□C/G39/G39A/G39C/K39/K39A/K39C), DIN terminal type (D-A44/A44A/A44C) and Heat resistant auto switch (D-F7NJL) meet the IEC529 standard.

Note 3) IP63, JIS C 0920 Rainproof construction
Except solid state switch with timer (D-M5□TL, G5NTL/F7NTL/F5NTL) and magnetic resistant 2-color indication type solid state switch (D-P5DWL). D-J51: 5 ms or less

Note 4) Except D-J51 (1 mA or less at 100 VAC, 1.5 mA or less at 200 VAC), D-M5NW/M5PW/M5BW, D-F9BAL, D-P5DWL (1 mA or less at 24 VDC).

Lead Wire Length

Lead wire length indication

(Example) **D-A73L**

Lead wire length	
Nil	0.5 m
L	3 m
Z	5 m
N*	None

* Applicable for the connector type (D-□□C) only.

Note 1) Applicable auto switch with 5 m lead wire ("Z")

Reed switch: D-B53/B54, D - C 7 3 (C) / C 8 0 C , D - A 7 3 (C) (H) / A80C, D-A53/A54, D-Z73, D-90/97/90A/93A

Solid state switch: Manufactured upon receipt of order as standard.

(Example) **D-F8PL-61**

Flexible lead wire specifications

(D-Y59, D-Y69, D-Y7 and D-M9□/M9□V series use flexible lead wire as standard.)

Part No. of Lead Wires with Connectors

(Applicable only for connector type)

Model	Lead wire length
D-LC05	0.5 m
D-LC30	3 m
D-LC50	5 m

Note 2) The standard lead wire length of solid state switches with timer, water resistant 2-color indication type, wide range detection type or heat resistant 2-color indication type is 3 meters in length. (0.5 m is not available.)

Note 3) Lead wire lengths of 3 m and 5 m are standard for magnetic field resistant 2-color indicator type solid state switches. (0.5 m is not available.)

Note 4) Add "-61" at the end of the part number for the flexible lead wire except D-Y59, D-Y69, D-Y7 and D-M9□/M9□V type auto switches.

Auto Switch Hysteresis

Hysteresis is the distance between the position at which piston movement operates an auto switch to the position at which reverse movement turns the switch off. This hysteresis is included in part of the operating range (one side).

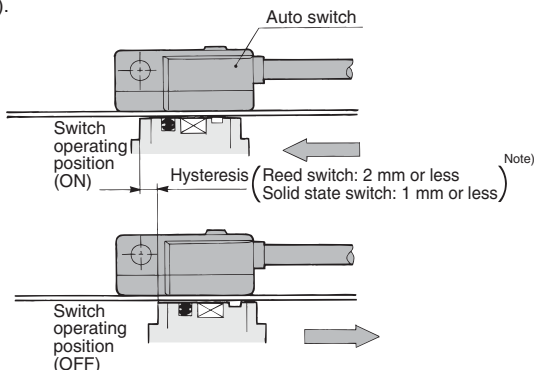

Note) Hysteresis may fluctuate due to the operating environment. Please contact SMC if hysteresis causes an operational problem.

Contact Protection Box: CD-P11, CD-P12

1

<Applicable switch types>

D-A7/A8, D-A7□H/A80H, D-A73C/A80C, D-C7/C8, D-C73C/C080C, D-E7□A/E80A, D-Z7/Z8, D-9/9□A, D-A9/A9□V, and D-A79W type

The above auto switches do not have internal contact protection circuits.

1. Operating load is an inductive load.
2. The length of wiring to the load is 5 m or more.
3. The load voltage is 100 or 200 VAC.

A contact protection box should be used in any of the above conditions. Unless using a contact protection box, the contact life may be shortened. (Due to permanent energizing conditions.)

D-A72(H) must be used with the contact protection box regardless of load styles and lead wire length.

2

Please contact SMC when using built-in contact protection circuit style (D-A34[A][C], D-A44[A][C], D-A54/A64, D-B54/B64, D-A59W, D-B59W) in the following conditions: 1. The wiring length to load is more than 30 m; 2. When using PLC with large flow current.

Contact Protection Box Specifications

Part no.	CD-P11	CD-P12
Load voltage	100 VAC or less	200 VAC
Max. load current	25 mA	12.5 mA
		50 mA

* Lead wire length — Switch connection side 0.5 m
Load connection side 0.5 m

Contact Protection Box Internal Circuit

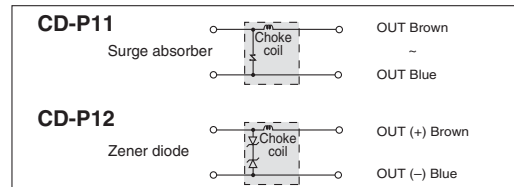

Contact Protection Box Connection

To connect a switch unit to a contact protection box, connect the lead wire from the side of the contact protection box marked SWITCH to the lead wire coming out of the switch unit. Keep the switch as close as possible to the contact protection box, with a lead wire length of no more than 1 meter.

Reed Switch Band Mounting Style D-C73/D-C76/D-C80

CE For details about certified products conforming to international standards, visit us at www.smcworld.com.

Grommet



Auto Switch Specifications

PLC: Abbreviation of Programmable Logic Controller

D-C7 (With indicator light)			
Auto switch model	D-C73		D-C76
Applicable load	Relay, PLC		IC circuit
Load voltage	24 VDC	100 VAC	4 to 8 VDC
Max. load current and range ⁽³⁾	5 to 40 mA	5 to 20 mA	20 mA
Contact protection circuit	None		
Internal voltage drop	2.4 V or less		0.8 V or less
Indicator light	Red LED lights when ON.		
D-C8 (Without indicator light)			
Auto switch model	D-C80		
Applicable load	Relay, PLC, IC circuit		
Load voltage	24 V _{DC} ^{AC} or less	48 V _{DC} ^{AC}	100 V _{DC} ^{AC}
Max. load current	50 mA	40 mA	20 mA
Contact protection circuit	None		
Internal resistance	1 Ω or less (Including lead wire length of 3 m)		

Auto Switch Internal Circuit

D-C73

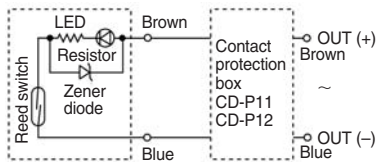

D-C76

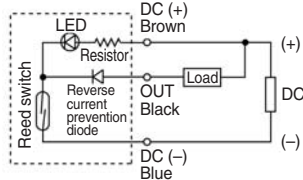

D-C80

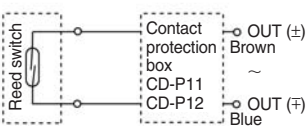

Note 1) Operating load is an induction load.
 Note 2) Wiring to the load is 5 m or longer.
 Note 3) Load voltage is 100 VAC.
 Use the contact protection box in any of the above listed situations. The contact point life may decrease. (Refer to page Best Pneumatics for contact protection box.)

• Lead wire — Oil resistant vinyl heavy-duty cord, $\varnothing 3.4$, 0.2 mm², 3 cores (Brown, Black, Blue), 2 cores (Brown, Blue), 0.5 m

Note 1) Regarding the common specifications of the reed switches, refer to page 6-16-7.

Note 2) Regarding the lead wire length, refer to page 6-16-7.

Note 3) Under 5 mA, the strength of the indicator light is poor. In some cases, visibility of the indicator light will not be possible where the output signal is less than 2.5 mA. However, there is no problem in terms of contact output, when an output signal exceeds 1 mA or more.

Weight

(g)				
Auto switch model		D-C73	D-C76	D-C80
Lead wire length (m)	0.5	9	10	9
	3	46	50	46
	5	76	—	—

Dimensions

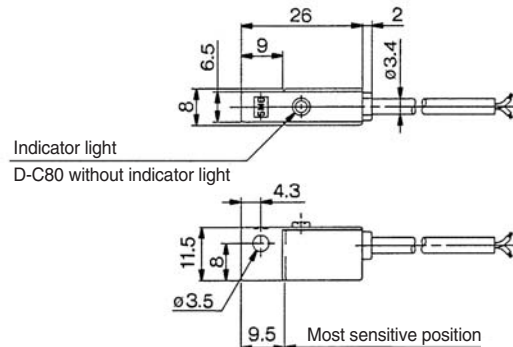

Reed Switch Band Mounting Style D-C73C/D-C80C

CE For details about certified products conforming to international standards, visit us at www.smworld.com.

Connector



Caution

Precautions

1. Confirm that the connector is appropriately tightened. If tightened insufficiently, the waterproof performance will deteriorate.
2. For details, refer to page 6-16-63.

Auto Switch Internal Circuit

D-C73C

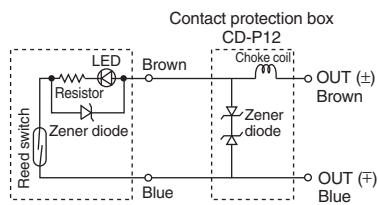

D-C80C

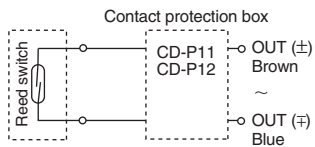

Note 1) Operating load is an induction load.
Note 2) Wiring to the load is 5 m or longer.
Use the contact protection box in any of the above listed situations. The contact point life may decrease. (Refer to page 6-16-7 for contact protection box.)

Auto Switch Specifications

PLC: Abbreviation of Programmable Logic Controller

D-C73C (With indicator light)

Auto switch model	D-C73C
Applicable load	Relay, PLC
Load voltage	24 VDC
Load current range ⁽⁴⁾	5 to 40 mA
Contact protection circuit	None
Internal voltage drop	2.4 V or less
Indicator light	Red LED lights when ON.

D-C80C (Without indicator light)

Auto switch model	D-C80C
Applicable load	Relay, PLC
Load voltage	24 V _{DC} ^{AC} or less
Maximum load current	50 mA
Contact protection circuit	None
Internal resistance	1 Ω (Including lead wire length of 3 m)

• Lead wire — Oil resistant vinyl heavy-duty cord, ø3.4, 0.2 mm², 2 cores (Brown, Blue), 0.5 m

Note 1) Regarding the common specifications of the reed switches, refer to page 6-16-7.

Note 2) Regarding the lead wire length, refer to page 6-16-7.

Note 3) Lead wire with connector may be shipped with switch.

Note 4) Under 5 mA, the strength of the indicator light is poor. In some cases, visibility of the indicator light will not be possible where the output signal is less than 2.5 mA. However, there is no problem in terms of contact output, when an output signal exceeds 1 mA or more.

Weight

Auto switch model			(g)
	D-C73C	D-C80C	
Lead wire length (m)	0.5	14	14
	3	53	53
	5	83	83

Dimensions

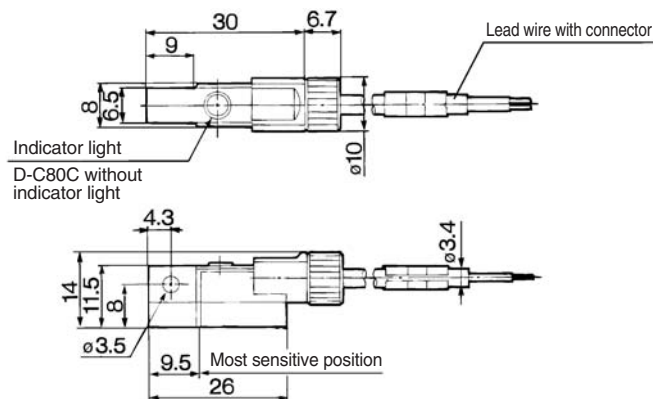

2-color Indication Type Reed Switch Band Mounting Style D-B59W

CE For details about certified products conforming to international standards, visit us at www.smcworld.com.

Grommet

The optimum operating position can be determined by the color of the light.
(Red → Green ← Red)



Auto Switch Internal Circuit

D-B59W

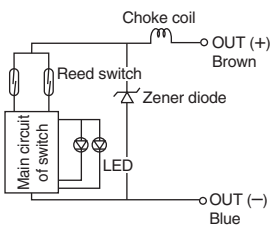

Indicator light/Display method

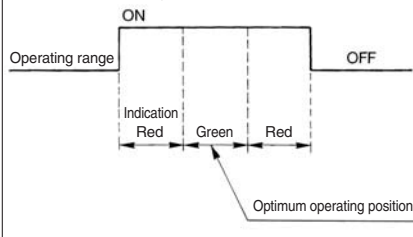

Auto Switch Specifications

PLC: Abbreviation of Programmable Logic Controller

D-B59W (With indicator light)	
Auto switch model	D-B59W
Applicable load	Relay, PLC
Load voltage	24 VDC
Load current range ⁽³⁾	5 to 40 mA
Contact protection circuit	Built-in
Internal voltage drop	4 V or less
Indicator light	Operating position.....Red LED lights when ON. Optimum operating position.....Green LED lights when ON.

• Lead wire — Oil resistant vinyl heavy-duty cord, $\phi 4$, 0.3 mm², 2 cores (Brown, Blue), 0.5 m

Note 1) Regarding the common specifications of the reed switches, refer to page 6-16-7.

Note 2) Regarding the lead wire length, refer to page 6-16-7.

Note 3) Under 5 mA, the strength of the indicator light is poor. In some cases, visibility of the indicator light will not be possible where the output signal is less than 2.5 mA. However, there is no problem in terms of contact output, when an output signal exceeds 1 mA or more.

Weight

Auto switch model		D-B59W
Lead wire length (m)	0.5	20
	3	76
	5	—

Dimensions

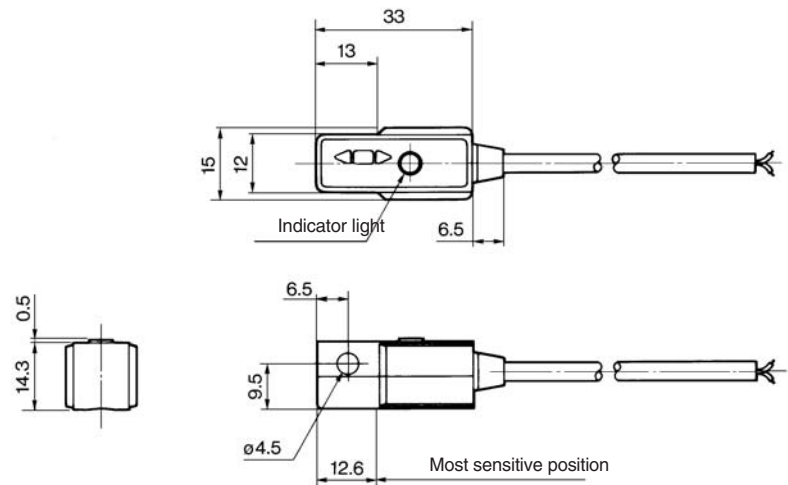

Solid State Switch: Direct Mounting Style

D-M9N(V)/D-M9P(V)/D-M9B(V)



Grommet

- 2-wire load current is reduced (2.5 to 40 mA).
- Flexibility is 1.5 times greater than the conventional model (SMC comparison).
- Using flexible cable as standard spec.



Caution

Precautions

Fix the switch with appropriate screw installed on the switch body. If using other screws, the switch may be damaged.

Auto Switch Internal Circuit

D-M9N(V)

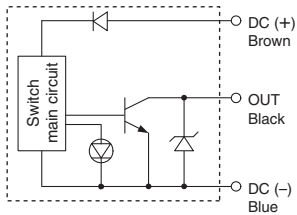

D-M9P(V)

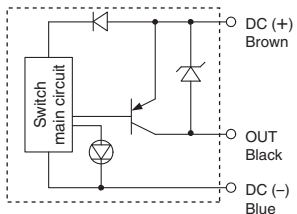

D-M9B(V)

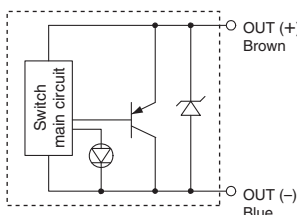

Auto Switch Specifications

PLC: Programmable Logic Controller

D-M9□(V) (With indicator light)						
Auto switch model	D-M9N	D-M9NV	D-M9P	D-M9PV	D-M9B	D-M9BV
Electrical entry direction	In-line	Perpendicular	In-line	Perpendicular	In-line	Perpendicular
Wiring type	3-wire				2-wire	
Output type	NPN		PNP		—	
Applicable load	IC circuit, Relay, PLC				24 VDC relay, PLC	
Power supply voltage	5, 12, 24 VDC (4.5 to 28 V)				—	
Current consumption	10 mA or less				—	
Load voltage	28 VDC or less		—		24 VDC (10 to 28 VDC)	
Load current	40 mA or less				2.5 to 40 mA	
Internal voltage drop	0.8 V or less at 10 mA (2 V or less at 40 mA)				4 V or less	
Leakage current	100 μA or less at 24 VDC				0.8 mA or less	
Indicator light	Red LED illuminates when turned ON.					
Standards	CE marking					

- Lead wires — Oilproof heavy-duty vinyl cable: $\phi 2.7 \times 3.2$ ellipse
 - D-M9B(V) 0.15 mm² x 2 cores
 - D-M9N(V), D-M9P(V) 0.15 mm² x 3 cores

Note 1) Refer to page 80 for solid state switch common specifications.

Note 2) Refer to Best Pneumatics for lead wire lengths.

Weight

Unit: g

Auto switch model	D-M9N(V)	D-M9P(V)	D-M9B(V)	
Lead wire length (m)	0.5	8	8	7
	1	14	14	13
	3	41	41	38
	5	68	68	63

Dimensions

Unit: mm

D-M9□

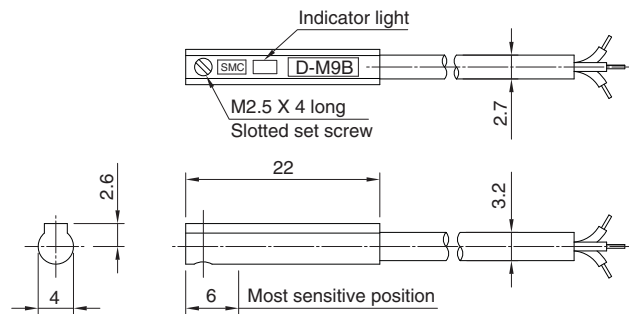

D-M9□V

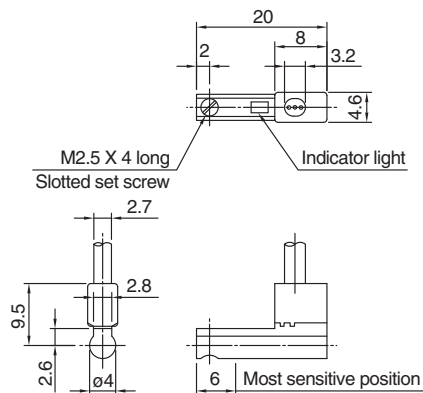

2-Color Indication Solid State Switch: Direct Mounting Style D-M9NW(V)/D-M9PW(V)/D-M9BW(V)

Grommet

- Decreased load current for 2-wire type (2.5 to 40 mA).
- RoHS compatible
- UL certified lead wire (style 2844)
- Flexible lead wire
- The optimum operating position can be determined by the color of the light. (Red → Green → Red)



Auto Switch Internal Circuit

D-M9NW/D-M9NWV

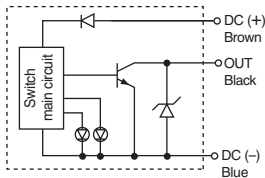

D-M9PW/D-M9PWV

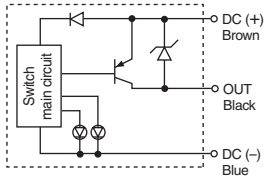

D-M9BW/D-M9BWV

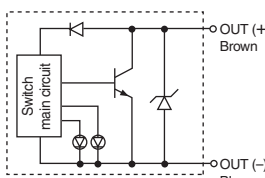

Indicator light/Display method

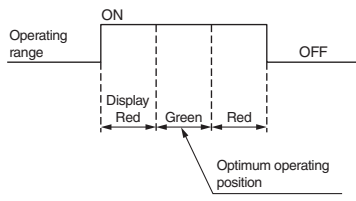

For details about certified products conforming to international standards, visit us at www.smcworld.com.

Auto Switch Specifications

PLC: Programmable Logic Controller

D-M9□W/D-M9□WV (With indicator light)						
Auto switch part no.	D-M9NW	D-M9NWV	D-M9PW	D-M9PWV	D-M9BW	D-M9BWV
Electrical entry direction	In-line	Perpendicular	In-line	Perpendicular	In-line	Perpendicular
Wiring type	3-wire				2-wire	
Output type	NPN		PNP		—	
Applicable load	IC circuit, Relay IC, PLC				24 VDC relay, PLC	
Power supply voltage	5, 12, 24 VDC (4.5 to 28 VDC)				—	
Current consumption	10 mA or less				—	
Load voltage	28 VDC or less		—		24 VDC (10 to 28 VDC)	
Load current	40 mA or less				2.5 to 40 mA	
Internal voltage drop	0.8 V or less at 10 mA load current (2 V or less at 40 mA load current)				4 V or less	
Leakage current	100μA or less at 24 VDC				0.8 mA or less	
Internal voltage drop	Operating position Red LED illuminates. Optimum operating position Green LED illuminates.					
Standard	Conforming to CE Standards					

Lead wires

Oilproof heavy-duty vinyl cable: $\phi 2.7 \times 3.2$ ellipse
 D-M9BW(V) 0.15 mm² x 2 cores
 D-M9NW(V), D-M9PW(V) 0.15 mm² x 3 cores

Note 1) Regarding common specifications of the solid state switches, refer to page 80.
 Note 2) Regarding lead wire lengths, refer to Best Pneumatics.

Weight

Unit: oz (g)

Auto switch part no.	D-M9NW(V)		D-M9PW(V)		D-M9BW(V)	
Lead wire length (m)	0.5	0.28 (8)	0.28 (8)	0.25 (7)		
	1	0.49 (14)	0.49 (14)	0.46 (13)		
	3	1.45 (41)	1.45 (41)	1.34 (38)		
	5	2.40 (68)	2.40 (68)	2.22 (63)		

Dimensions

Unit: mm

D-M9□W

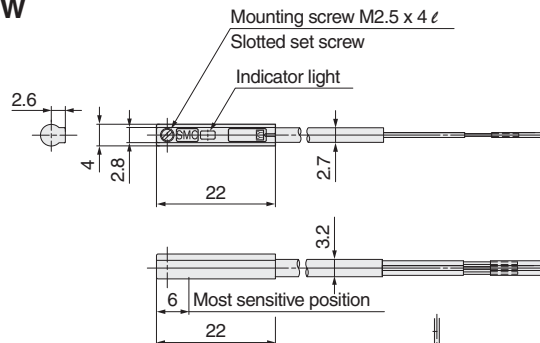

D-M9□WV

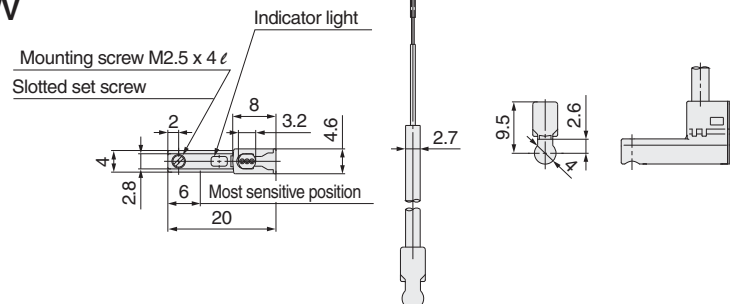

2-color Indication Type Solid State Switch Band Mounting Style D-G59W/D-G5PW/D-K59W

Grommet

The optimum operating position can be determined by the color of the light.

(Red → Green ← Red)



For details about certified products conforming to international standards, visit us at www.smcworld.com.

Auto Switch Specifications

PLC: Abbreviation of Programmable Logic Controller

D-G5□W, D-K59W (With indicator light)			
Auto switch model	D-G59W	D-G5PW	D-K59W
Wiring type	3-wire		2-wire
Output type	NPN	PNP	—
Applicable load	IC circuit, Relay, PLC		24 VDC Relay, PLC
Power supply voltage	5, 12, 24 VDC (4.5 to 28 VDC)		—
Current consumption	10 mA or less		—
Load voltage	28 VDC or less	—	24 VDC (10 to 28 VDC)
Load current	40 mA or less	80 mA or less	5 to 40 mA
Internal voltage drop	1.5 V or less (0.8 V or less at 10 mA load current)	0.8 V or less	4 V or less
Leakage current	100 μA or less at 24 VDC		0.8 mA or less at 24 VDC
Indicator light	Operating position.....Red LED lights when ON. Optimum operating position.....Green LED lights when ON.		

• Lead wire — Oil resistant vinyl heavy-duty cord, $\phi 4$, 0.3 mm², 3 cores (Brown, Black, Blue), 2 cores (Brown, Blue), 0.5 m

Note 1) Regarding the common specifications of the solid state switches, refer to page 6-16-7.

Note 2) Regarding the lead wire length, refer to page 6-16-7.

Auto Switch Internal Circuit

D-G59W

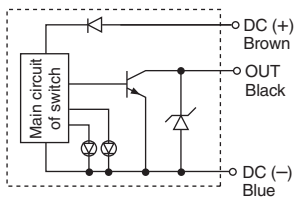

D-G5PW

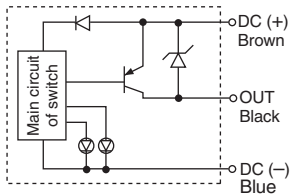

D-K59W

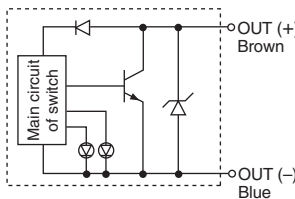

Indicator light/Display method

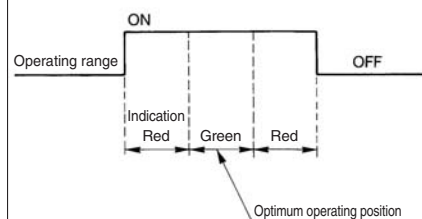

Weight

(g)				
Auto switch model	D-G59W	D-G5PW	D-K59W	
Lead wire length (m)	0.5	20	20	18
	3	78	78	68
	5	124	124	108

Dimensions

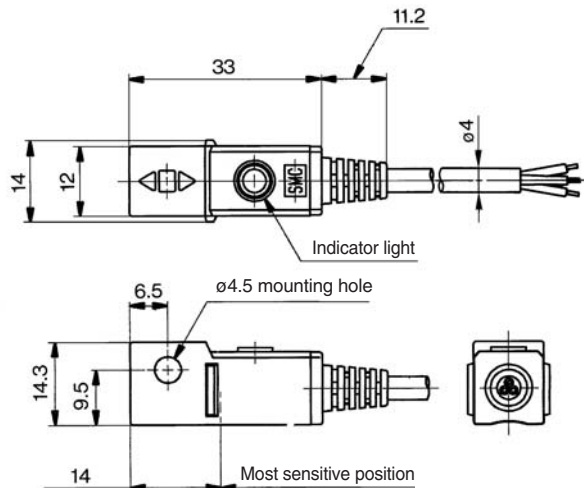

2-color Indication Type with Diagnostic Output Solid State Switch: Band Mounting Style D-G59F

For details about certified products conforming to international standards, visit us at www.smcworld.com.

Grommet

Since the output signal can be detected in an unsteady detecting area, the difference of detecting position can be confirmed by the side of PLC (Programmable Logic Controller).



Auto Switch Internal Circuit

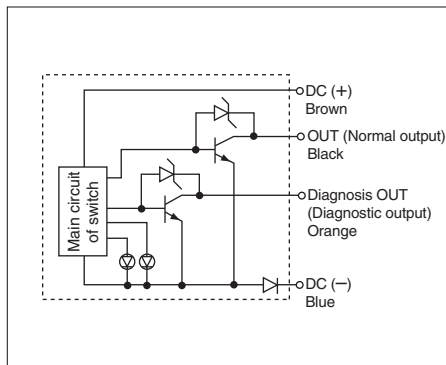

Auto Switch Specifications

PLC: Abbreviation of Programmable Logic Controller

D-G59F (with indicator light)	
Auto switch model	D-G59F
Wiring	4-wire
Output	NPN
Diagnostic output	Normal operation
Applicable load	IC circuit, Relay, PLC
Power voltage	5, 12, 24 VDC (4.5 to 28 VDC)
Current consumption	10 mA or less
Load voltage	28 VDC or less
Load current	50 mA or less at the total amount of normal output and diagnostic output
Internal voltage drop	1.5 V or less (0.8 V or less at 5 mA)
Current leakage	100 μ A or less at 24 VDC
Indicator light	Operating position.....Red LED lights when ON. Optimum operating position.....Green LED lights when ON.

- Lead wire — Oil resistant vinyl heavy-duty cord, ϕ 4, 0.2 mm², 4 cores (Brown, Black, Orange, Blue), 0.5 m

Note 1) Regarding the common specifications of the solid state switches, refer to page 6-16-7.

Note 2) Regarding the lead wire length, refer to page 6-16-7.

Weight

Auto switch model	D-G59F	
Lead wire length (m)	0.5	20
	3	74
	5	117

Diagnostic Output Operation

The diagnostic signal is output within unsteady detecting area (where indicator light is Red), and the diagnostic output becomes OFF when the detecting position remains within the optimum operating position (where indicator is Green). When the detecting position is not adjusted, the diagnostic output becomes ON.

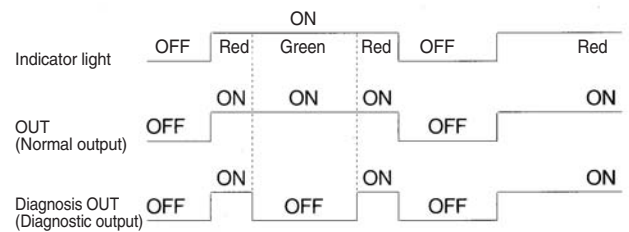

Dimensions

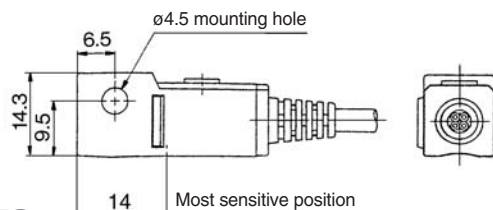
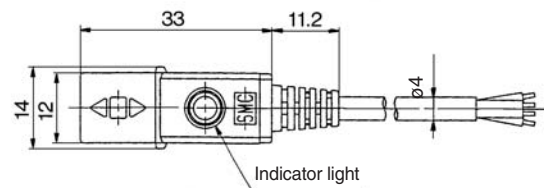

Water Resistant 2-Color Indication Solid State Switch: Direct Mounting Style D-M9NA(V)/D-M9PA(V)/D-M9BA(V)



Grommet

- Water (coolant) resistant type
- 2-wire load current is reduced (2.5 to 40 mA).
- RoHS compliant
- UL certified (style 2844) lead cable is used.

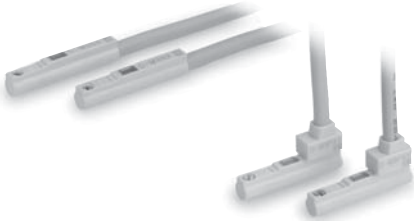

Auto Switch Internal Circuit

D-M9NA(V)

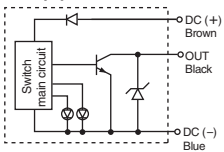

D-M9PA(V)

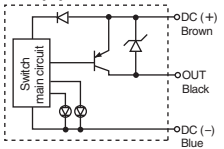

D-M9BA(V)

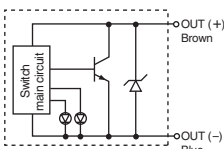

Indicator light / Display method

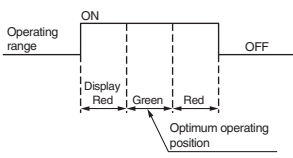

Auto Switch Specifications

PLC: Programmable Logic Controller

D-M9□A/D-M9□AV (With indicator light)						
Auto switch part no.	D-M9NA	D-M9NAV	D-M9PA	D-M9PAV	D-M9BA	D-M9BAV
Electrical entry direction	In-line	Perpendicular	In-line	Perpendicular	In-line	Perpendicular
Wiring type	3-wire			2-wire		
Output type	NPNPNP			—		
Applicable load	IC circuit, Relay, PLC			24 VDC relay, PLC		
Power supply voltage	5, 12, 24 VDC (4.5 to 28 V)			—		
Current consumption	10 mA or less			—		
Load voltage	28 VDC or less		—		24 VDC (10 to 28 VDC)	
Load current	40 mA or less			2.5 to 40 mA		
Internal voltage drop	0.8 V or less at 10 mA (2 V or less at 40 mA)			4 V or less		
Leakage current	100 μA or less at 24 VDC			0.8 mA or less		
Indicator light	Operating position Red LED illuminates. Optimum operating position Green LED illuminates.					

- Lead wires — Oilproof heavy-duty vinyl cable: $\phi 2.7 \times 3.2$ ellipse
- D-M9BA(V) 0.15 mm² x 2 cores
- D-M9NA(V), D-M9PA(V) 0.15 mm² x 3 cores

Solid State Switch Specifications

Leakage current	3-wire: 100μA or less 2-wire: 0.8 mA or less
Operating time	1 ms or less
Impact resistance	1000 m/s ²
Insulation resistance	50 MΩ or more at 500 VDC Mega (between lead wire and case)
Withstand voltage	1000 VAC for 1 minute (between lead wire and case)
Ambient temperature	-10 to 60°C
Enclosure	IEC60529 standard IP67, JIS C 0920 waterproof construction

Weight

Unit: g

Auto switch part no.	D-M9NA(V)	D-M9PA(V)	D-M9BA(V)
Lead wire length (m)			
0.5	8	8	7
1	14	14	13
3	41	41	38
5	68	68	63

Dimensions

Unit: mm

D-M9□A

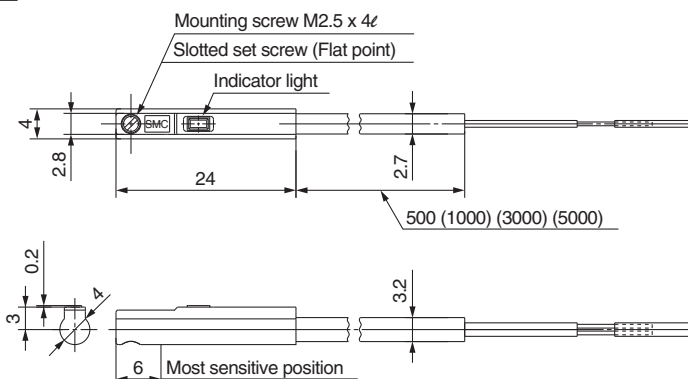

D-M9□AV

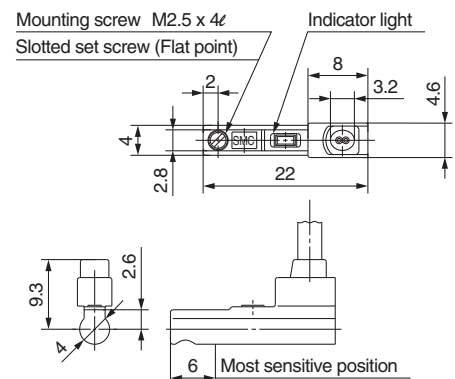

Water Resistant 2-color Indication Type Solid State Switch: Band Mounting Style **D-G5BAL**



For details about certified products conforming to international standards, visit us at www.smcworld.com.

Grommet

Water (coolant) resistant type



⚠ Caution

Precautions

Please consult with SMC if using coolant liquid other than water based solution.

Auto Switch Specifications

PLC: Abbreviation of Programmable Logic Controller

D-G5BAL (With indicator light)	
Auto switch model	D-G5BAL
Wiring type	2-wire
Output type	—
Applicable load	24 VDC Relay, PLC
Power supply voltage	—
Current consumption	—
Load voltage	24 VDC (10 to 28 VDC)
Load current	5 to 40 mA
Internal voltage drop	4 V or less
Leakage current	0.8 mA or less at 24 VDC
Indicator light	Operating position.....Red LED lights when ON. Optimum operating position.....Green LED lights when ON.

- Lead wire — Oil resistant vinyl heavy-duty cord, $\phi 3.4$, 0.2 mm², 2 cores (Brown, Blue), 3 m (Standard)
- Note 1) Regarding the common specifications of the solid state switches, refer to page 6-16-7.
- Note 2) Regarding the lead wire length, refer to page 6-16-7.

Weight

Auto switch model		D-G5BA
Lead wire length (m)	0.5	—
	3	68
	5	108

Auto Switch Internal Circuit

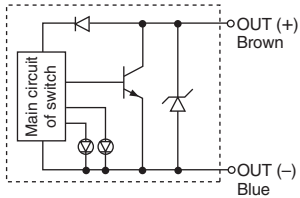

Indicator light/Display method

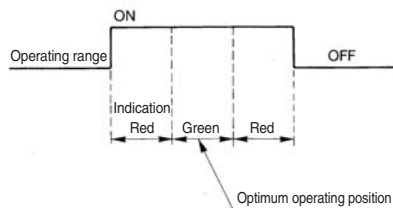

Dimensions

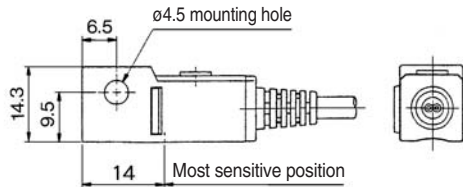
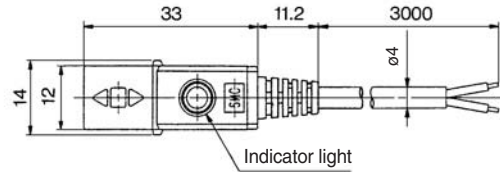

Technical Data 1: Plug-in Connector Assembly/ How to Use DIN Terminal

Plug-in Connector Assembly

D-A73C/A80C, D-J79C
D-C73C/C80C, D-H7C

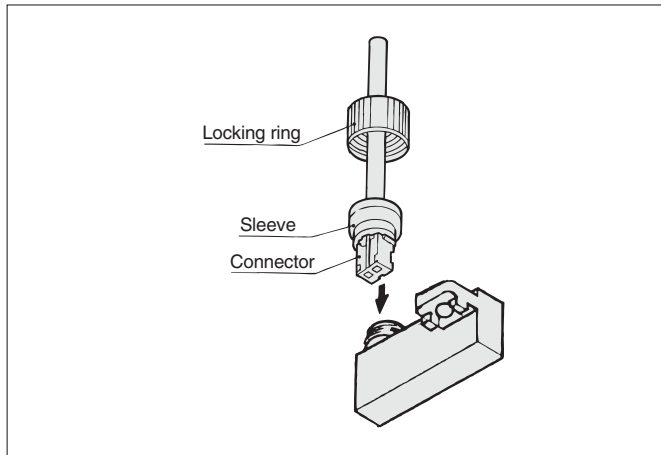

With the convex port of the connector, insert the connector into the auto switch into the sleeve. Screw the locking ring onto the switch. (Do not tighten with pliers.)

How to Use DIN Terminal: D-A44/A44A/A44C

Connection procedure

1. Loosen the set screw and pull out the connector from the pin plug.
2. Be sure to remove the set screw first and then insert a screwdriver into a recessed groove under the terminal block to separate the terminal cover from the terminal block.
3. Follow the procedures and connect wires securely to specified terminals.
4. In standard cases, crimp-style terminals are used to connect wires. Please select proper crimp-style terminals so that the wire can be properly connected to terminal fittings.

How to connect

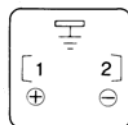

- AC:
Connect to terminal no. 1 and no. 2
DC:
Connect (+) to no. 1 terminal and (-) to no. 2 terminal.

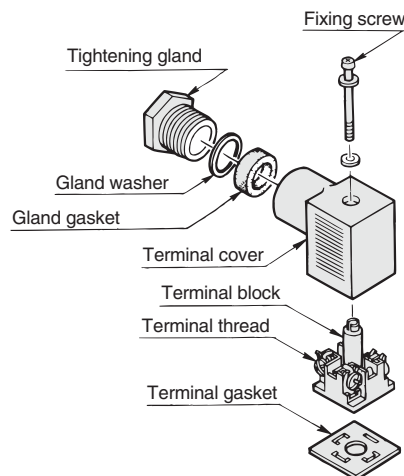

How to change position of electrical entry

After separating the terminal block from the terminal cover, change the position of the terminal cover to any desired direction (4 directions at every 90°) to change the position of electrical entry.

Caution

When plugging a connector in the pin plug or pulling it out, hold a connector perpendicularly as much as possible, not to slant it.

Applicable cable (Heavy-duty cord)

Applicable to cable O.D. of $\phi 6.8$ to $\phi 11.5$.

Applicable crimp-style terminal

1.25Y-3L, 1.25-3.5S, 1.25-4M

Technical Data 2: How to Mount and Move the Auto Switch

Mounting Bracket Band Mounting Style

⚠ Caution

1. Tighten the screw under the specified torque when mounting auto switch.
2. Set the mounting band perpendicularly to cylinder tube.

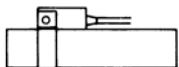

Mounting correctly

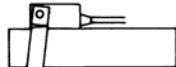

Mounting incorrectly

<Applicable auto switch>

Reed switch.....D-B53, D-B54, D-B64, D-B59W
Solid state switch.....D-G59, D-G5P, D-K59, D-G5BAL
D-G59W, D-G5PW, D-K59W, D-G59F, D-G5NTL

How to Mount and Move the Auto Switch

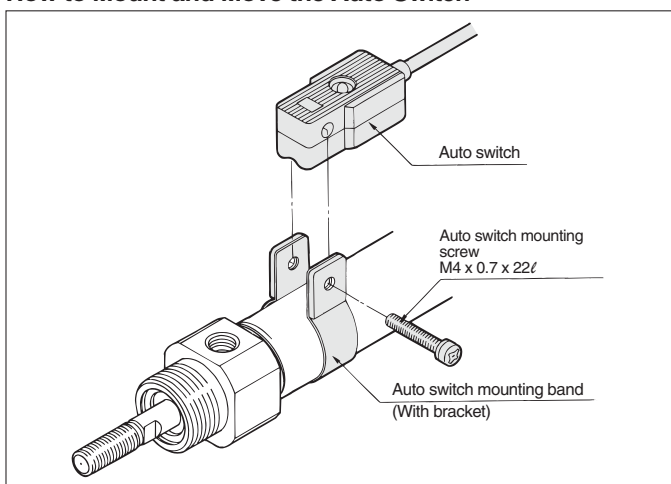

1. Put a mounting band on the cylinder tube and set it at the auto switch mounting the mounting hole to the hole of stationary fitting.
2. Put the mounting section of the auto switch between the band mounting holes, then adjust the position of mounting holes of switch to those of mounting band.
3. Lightly thread the auto switch mounting screw through the mounting hole into the thread part of band fitting.
4. After reconfirming the detecting position, tighten the mounting screw to secure the auto switch. (The tightening torque of M4 screw should be about 1 to 1.2 N·m.)
5. Modification of the detection position should be made in the condition of 3.

Auto Switch Mounting Bracket Part No. (Including band and screw)

Cylinder series	Applicable bore size (mm)							
	20	25	32	40	50	63	80	100
CDM2, CDBM2	BA2	BA2	BA2	BA2	—	—	—	—
CDVM3/5, CDLM2	-020	-025	-032	-040	—	—	—	—
CDG1, MGG	BA	BA	BA	BA	BA	BA-06	BA-08	BA-10
MGC	-01	-02	-32		-05	—	—	—
CDLG1	—	—	—		—	—	—	—
CDV3, CNA	—	—	—		-04	—	—	—
CDVS, CDL1, CE2	—	—	—	—	BA	BA	BA	BA
RHC, MLGC, REC	BA-01	BA-02	BA-32	—	-05	-06	-08	-10

[Mounting screws set made of stainless steel]

The following set of mounting screws made of stainless steel is also available. Use it in accordance with the operating environment. (Please order the mounting band separately, since it is not included.)

BBA3: For D-B5/B6/G5/K5

"D-G5BAL" switch is set on the cylinder with the stainless steel screws above when shipped.

When a switch is shipped independently, "BBA3" screws are attached.

<Applicable auto switch>

Reed switch.....D-C73, D-C76, D-C80, D-C73C, D-C80C
Solid state switch.....D-H7A1, D-H7A2, D-H7B, D-H7BAL
D-H7C, D-H7NF, D-H7NW, D-H7PW, D-H7BW

How to Mount and Move the Auto Switch

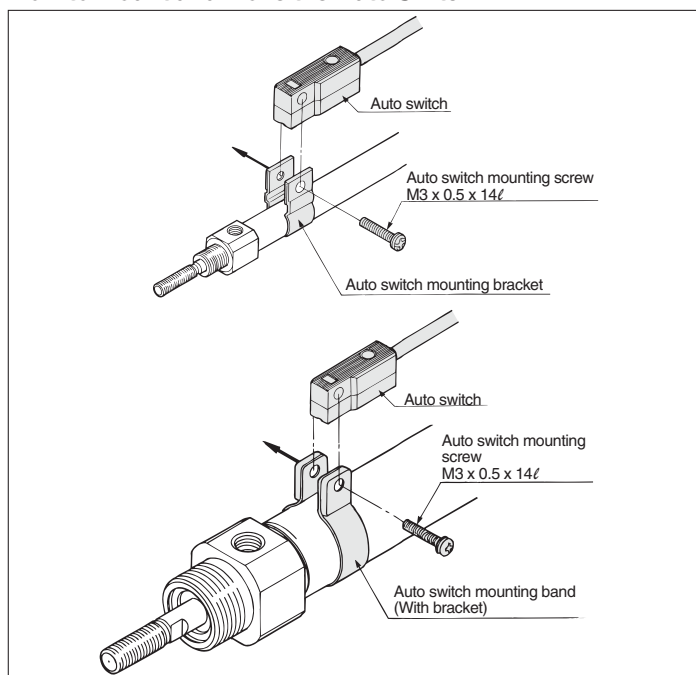

1. For Series CDJ2: Put a mounting bracket on the cylinder tube.
For Series CDM2: Put a mounting band on the cylinder tube and set it at the auto switch mounting position.
2. Put the mounting section of the auto switch between the band mounting holes, then adjust the position of mounting holes of switch to those of mounting band.
3. Lightly thread the auto switch mounting screw through the mounting hole into the thread part of band fitting.
4. Set the whole body to the detecting position by sliding, tighten the mounting screw to secure the auto switch. (Tightening torque of M3 screw should be 0.8 to 1.0 N·m.)
5. Modification of the detection position should be made in the condition of 3.
6. After auto switch is mounted and fixed, attach a protective tube on the tip of an auto switch mounting screw.

Auto Switch Mounting Bracket Part No. (Including band and screw)

Cylinder series	Applicable bore size (mm)									
	6	10	15	16	20	25	32	40	50	63
CDJ2	BJ2-006	BJ2	—	BJ2	—	—	—	—	—	—
CDVJ3/5	—	-010	—	-016	—	—	—	—	—	—
CDLJ2	—	—	—	—	—	—	—	—	—	—
CDM2, CDBM2	—	—	—	—	BM2	BM2	BM2	BM2	—	—
CDVM3/5, CDLM2	—	—	—	—	-020	-025	-032	-040	—	—
CDG1, MGG	—	—	—	—	—	—	—	—	BMA2-050	BMA2-063
CDLG1	—	—	—	—	—	—	—	—	—	—
MGC	—	—	—	—	BMA2	BMA2	BMA2	BMA2	BMA2-050	—
RHC, MLGC, REC	—	—	—	—	-020	-025	-032	-040	—	—
RSDG	—	—	—	—	—	—	—	—	BMA2-050	—

[Mounting screws set made of stainless steel]

The following set of mounting screws made of stainless steel is also available. Use it in accordance with the operating environment. (Please order the mounting band separately, since it is not included.)

BBA4: For D-C7/C8/H7

"D-H7BAL" switch is set on the cylinder with the stainless steel screws above when shipped.

When only a switch is shipped independently, "BBA4" screws are attached.



Safety Instructions

These safety instructions are intended to prevent a hazardous situation and/or equipment damage. These instructions indicate the level of potential hazard by labels of "**Caution**", "**Warning**" or "**Danger**". To ensure safety, be sure to observe ISO 4414 ^{Note 1)}, JIS B 8370 ^{Note 2)} and other safety practices.

 **Caution** : Operator error could result in injury or equipment damage.

 **Warning** : Operator error could result in serious injury or loss of life.

 **Danger** : In extreme conditions, there is a possible result of serious injury or loss of life.

Note 1) ISO 4414: Pneumatic fluid power--General rules relating to systems.

Note 2) JIS B 8370: General Rules for Pneumatic Equipment

Warning

1. The compatibility of pneumatic equipment is the responsibility of the person who designs the pneumatic system or decides its specifications.

Since the products specified here are used in various operating conditions, their compatibility for the specific pneumatic system must be based on specifications or after analysis and/or tests to meet your specific requirements. The expected performance and safety assurance will be the responsibility of the person who has determined the compatibility of the system. This person should continuously review the suitability of all items specified, referring to the latest catalog information with a view to giving due consideration to any possibility of equipment failure when configuring a system.

2. Only trained personnel should operate pneumatically operated machinery and equipment.

Compressed air can be dangerous if an operator is unfamiliar with it. Assembly, handling or repair of pneumatic systems should be performed by trained and experienced operators.

3. Do not service machinery/equipment or attempt to remove components until safety is confirmed.

1. Inspection and maintenance of machinery/equipment should only be performed once measures to prevent falling or runaway of the driver objects have been confirmed.
2. When equipment is to be removed, confirm the safety process as mentioned above. Cut the supply pressure for this equipment and exhaust all residual compressed air in the system.
3. Before machinery/equipment is restarted, take measures to prevent shooting-out of cylinder piston rod, etc.

4. Contact SMC if the product is to be used in any of the following conditions:

1. Conditions and environments beyond the given specifications, or if product is used outdoors.
2. Installation on equipment in conjunction with atomic energy, railway, air navigation, vehicles, medical equipment, food and beverages, recreation equipment, emergency stop circuits, clutch and brake circuits in press applications, or safety equipment.
3. An application which has the possibility of having negative effects on people, property, or animals, requiring special safety analysis.



Safety Instructions

Caution

The product is provided for use in manufacturing industries.

The product herein described is basically provided for peaceful use in manufacturing industries.

If considering using the product in other industries, consult SMC beforehand and exchange specifications or a contract if necessary. If anything is unclear, contact your nearest sales branch. (1-800-SMC-SMC1)

Limited Warranty and Disclaimer/Compliance Requirements

The product used is subject to the following “Limited Warranty and Disclaimer” and “Compliance Requirements”. Read and accept them before using the product.

Limited Warranty and Disclaimer

- 1. The warranty period of the product is 1 year in service or 1.5 years after the product is delivered. Also, the product may have specified durability, running distance or replacement parts. Please consult your nearest sales branch.**
- 2. For any failure or damage reported within the warranty period which is clearly our responsibility, a replacement product or necessary parts will be provided. This limited warranty applies only to our product independently, and not to any other damage incurred due to the failure of the product.**
- 3. Prior to using SMC products, please read and understand the warranty terms and disclaimers noted in the specified catalog for the particular products.**



Actuator Precautions 1

Be sure to read before handling.

For detailed precautions on every series, refer to main text.

Caution on Design

⚠ Warning

1. There is a possibility of dangerous sudden action by air cylinders if sliding parts of machinery are twisted due to external forces, etc.

In such cases, human injury may occur; e.g., by catching hands or feet in the machinery, or damage to the machinery itself may occur. Therefore, the machine should be adjusted to operate smoothly and designed to avoid such dangers.

2. A protective cover is recommended to minimize the risk of personal injury.

If a stationary object and moving parts of a cylinder are in close proximity, personal injury may occur. Design the structure to avoid contact with the human body.

3. Securely tighten all stationary parts and connected parts so that they will not become loose.

Especially when a cylinder operates with high frequency or is installed where there is a lot of vibration, ensure that all parts remain secure.

4. A deceleration circuit or shock absorber may be required.

When a driven object is operated at high speed or the load is heavy, a cylinder's cushion will not be sufficient to absorb the impact. Install a deceleration circuit to reduce the speed before cushioning, or install an external shock absorber to relieve the impact.

In this case, the rigidity of the machinery should also be examined.

5. Consider a possible drop in circuit pressure due to a power outage, etc.

When a cylinder is used in a clamping mechanism, there is a danger of workpieces dropping if there is a decrease in clamping force due to a drop in circuit pressure caused by a power outage, etc. Therefore, safety equipment should be installed to prevent damage to machinery and human injury. Suspension mechanisms and lifting devices also require consideration for drop prevention.

6. Consider a possible loss of power source.

Measures should be taken to protect against bodily injury and equipment damage in the event that there is a loss of power to equipment controlled by pneumatics, electricity, or hydraulics.

7. Design circuitry to prevent sudden lurching of driven objects.

When a cylinder is driven by an exhaust center type directional control valve or when starting up after residual pressure is exhausted from the circuit, etc., the piston and its driven object will lurch at high speed if pressure is applied to one side of the cylinder because of the absence of air pressure inside the cylinder. Therefore, equipment should be selected and circuits designed to prevent sudden lurching, because there is a danger of human injury and/or damage to equipment when this occurs.

8. Consider emergency stops.

Design so that human injury and/or damage to machinery and equipment will not be caused when machinery is stopped by a safety device under abnormal conditions, a power outage or a manual emergency stop.

Caution on Design

9. Consider the action when operation is restarted after an emergency stop or abnormal stop.

Design the machinery so that human injury or equipment damage will not occur upon restart of operation.

When the cylinder has to be reset at the starting position, install manual safety equipment.

Selection

⚠ Warning

1. Confirm the specifications.

The products featured in this catalog are designed for use in industrial compressed air systems. If the products are used in conditions where pressure and/or temperature are outside the range of specifications, damage and/or malfunctions may occur. Do not use in these conditions. (Refer to the specifications.)

Please consult with SMC if you use a fluid other than compressed air.

2. About intermediate stop

In the case of 3 position closed center of a valve, it is difficult to make a piston stop at the required position as accurately and precisely as with hydraulic pressure due to compressibility of air.

Furthermore, since valves and cylinders, etc. are not guaranteed for zero air leakage, it may not be possible to hold a stopped position for an extended period of time. Please contact SMC in the case it is necessary to hold a stopped position for an extended period.

⚠ Caution

1. Operate within the limits of the maximum usable stroke.

Refer to the selection procedures for the air cylinder to be used for the maximum usable stroke.

2. Operate the piston within a range such that collision damage will not occur at the stroke end.

The operation range should prevent damage from occurring when a piston, having inertial force, stops by striking the cover at the stroke end. Refer to the cylinder model selection procedure for the maximum usable stroke.

3. Use a speed controller to adjust the cylinder drive speed, gradually increasing from a low speed to the desired speed setting.

4. Provide intermediate supports for long stroke cylinders.

An intermediate support should be provided in order to prevent damage to a cylinder having a long stroke, due to problems such as sagging of the rod, deflection of the cylinder tube, vibration and external load.



Actuator Precautions 2

Be sure to read before handling.

For detailed precautions on every series, refer to main text.

Mounting

⚠ Caution

1. **Be certain to match the rod shaft center with the load and direction of movement when connecting.**

When not properly matched, problems may arise with the rod and tube, and damage may be caused due to friction on areas such as the inner tube surface, bushings, rod surface, and seals.

2. **When an external guide is used, connect the rod end and the load in such a way that there is no interference at any point within the stroke.**
3. **Do not scratch or gouge the sliding portion of the cylinder tube or the piston rod by striking it with an object, or squeezing it.**

The tube bore is manufactured under precise tolerances. Thus, even a slight deformation could lead to a malfunction.

Moreover, scratches or gouges, etc. in the piston rod may lead to damaged seals and cause air leakage.

4. **Prevent the seizure of rotating parts.**

Prevent the seizure of rotating parts (pins, etc.) by applying grease.

5. **Do not use until you verify that the equipment can operate properly.**

After mounting, repairs, or modification, etc., connect the air supply and electric power, and then confirm proper mounting by means of appropriate function and leak tests.

6. **Instruction manual**

Install the products and operate them only after reading the instruction manual carefully and understanding its contents. Also keep the manual where it can be referred to as necessary.

Piping

⚠ Caution

1. **Before piping**

Before piping, it should be thoroughly blown out with air (flushing) or washed to remove chips, cutting oil and other debris from inside the pipe.

2. **Wrapping of pipe tape**

When screwing piping or fittings into ports, ensure that chips from the pipe threads or sealing material do not get inside the piping.

Also, when the pipe tape is used, leave 1.5 to 2 thread ridges exposed at the end of the threads.

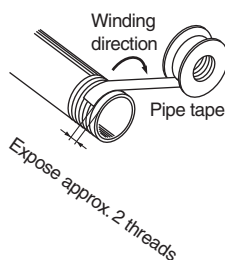

Cushion

⚠ Caution

1. **Readjust with the cushion needle.**

Cushions are adjusted at the time of shipment, however, the cushion needle on the cover should be readjusted when the product is put into service, based upon factors such as the size of the load and the operating speed. When the cushion needle is turned clockwise, the restriction becomes smaller and the cushion's effectiveness is increased. Tighten the lock nut securely after adjustment is performed.

2. **Do not operate the actuator with the cushion needle fully closed.**

This could damage the seals.

Lubrication

⚠ Caution

1. **Lubricating the lube style cylinder.**

Install a lubricator in the circuit, and use Class 1 turbine oil (with no additive) ISO VG32.

Do not use machine oil or spindle oil.

2. **Lubrication of cylinder**

The cylinder has been lubricated for life at the factory and can be used without any further lubrication.

However, in the event that it is lubricated additionally, be sure to use Class 1 turbine oil (with no additive) ISO VG32.

Stopping lubrication later may lead to malfunctions because the new lubricant will cancel out the original lubricant. Therefore, lubrication must be continued once it has been started.

Air Supply

⚠ Warning

1. **Use clean air.**

Do not use compressed air which contains chemicals, synthetic oils containing organic solvents, salts or corrosive gases, etc., as this can cause damage or malfunction.

⚠ Caution

1. **Install air filters.**

Install air filters close to valves at their upstream side. A filtration degree of 5 μm or less should be selected.

2. **Install an aftercooler, air dryer, or water separator (Drain Catch).**

Air that includes excessive drainage may cause malfunction of valves and other pneumatic equipment. To prevent this, install an air dryer, aftercooler or water separator, etc.

3. **Use the product within the specified range of fluid and ambient temperature.**

Take measures to prevent freezing when below 5°C, since moisture in circuits can freeze and cause damage to seals and lead to malfunctions.

For compressed air quality, refer to "Air Preparation Equipment" catalog.



Actuator Precautions 3

Be sure to read before handling.

For detailed precautions on every series, refer to main text.

Operating Environment

⚠ Warning

1. Do not use in atmospheres or locations where corrosion hazards exist.

Refer to the construction drawings regarding cylinder materials.

2. In dusty locations or where water or oil, etc., splash on the equipment, take suitable measures to protect the rod.

Use the heavy duty scraper type (-XC4) in situations where there is a lot of dust. Use a water resistant cylinder when there is splash or spray of liquids.

3. When using auto switches, do not operate in an environment with strong magnetic fields.

Maintenance

⚠ Warning

1. Perform maintenance procedures as shown in the instruction manual.

If it is handled improperly, malfunction or damage of machinery or equipment may occur.

2. Removal of equipment, and supply/exhaust of compressed air

Before any machinery or equipment is removed, first ensure that the appropriate measures are in place to prevent the fall or erratic movement of driven objects and equipment, then cut off the electric power and reduce the pressure in the system to zero. Only then should you proceed with the removal of any machinery and equipment.

When machinery is restarted, proceed with caution after confirming that appropriate measures are in place to prevent cylinders from sudden movement.

⚠ Caution

1. Drain flushing

Remove drainage from air filters regularly. (Refer to the specifications.)

Air-hydro

Caution on Design

⚠ Warning

1. Do not use air-hydro cylinder near flames, or in equipment or machinery that exceeds an ambient temperatures of 60C.

There is a danger of causing a fire because the air-hydro cylinder uses a flammable hydraulic fluid.

⚠ Caution

1. Do not use it in an environment, equipment, or machine that is not compatible with oil mist.

Air-hydro cylinders generate an oil mist during operation which may affect the environment.

2. Be sure to install an exhaust cleaner on the directional control valve for the air-hydro cylinder.

A very small amount of hydraulic fluid is discharged from the exhaust port of the air-hydro cylinder's directional control valve, and this may contaminate the surrounding area.

3. Install an air-hydro cylinder in locations where it can be serviced easily.

Since the air-hydro cylinder requires maintenance, such as refilling of hydraulic fluid and bleeding of air, ensure sufficient space for these activities.

Selection

⚠ Caution

1. Select an air-hydro cylinder in combination with an air-hydro unit.

Since good operation of an air-hydro cylinder depends on combination with an air-hydro unit, be sure to select an appropriate air-hydro unit.

2. Set the load of the air-hydro cylinder to be 50% or less of the theoretical force.

For an air-hydro cylinder to obtain constant speed and stopping accuracy close to that of a hydraulic cylinder, it is necessary to keep the load at 50% or less of the theoretical output.

Piping

⚠ Caution

1. For air-hydro cylinder piping, use self-aligning fittings.

Do not use One-touch fittings in the piping for an air-hydro cylinder, as oil leakage may occur.

2. For air-hydro cylinder piping, use hard nylon tubing or copper piping.

As in the case of hydraulic circuits, surge pressures greater than the operating pressure may occur in an air-hydro cylinder's piping, making it necessary to use safer piping materials.

Lubrication

⚠ Warning

1. Make sure to completely discharge the compressed air in the system before filling the air-hydro unit with hydraulic oil.

When supplying hydraulic fluid to the air-hydro unit, first confirm that safety measures are implemented to prevent dropping of driven objects and release of clamped objects, etc. Then, shut off the air supply and the equipment's electric power, and exhaust the compressed air in the system.

If the air-hydro unit is supply port is opened with compressed air still remaining in the system, there is a danger of hydraulic fluid being blown out.

Maintenance

⚠ Caution

1. Bleed air from the air-hydro cylinder on a regular basis.

Since air may accumulate inside an air-hydro cylinder, bleed air from it at times such as before starting work. Bleed air from a bleeder valve provided on the air-hydro cylinder or the piping.

2. Verify the oil level of the air hydro system on a regular basis.

Since a very small amount of hydraulic fluid is discharged from the air-hydro cylinder and air-hydro unit circuit, the fluid will gradually decrease. Therefore, check the fluid regularly and refill as necessary.

The oil level can be checked with a level gauge in the air-hydro converter.

Global Manufacturing, Distribution and Service Network

Worldwide Subsidiaries

EUROPE

AUSTRIA
SMC Pneumatik GmbH (Austria)

BELGIUM
SMC Pneumatics N.V./S.A.

BULGARIA
SMC Industrial Automation Bulgaria EOOD

CROATIA
SMC Industrijska Automatika d.o.o.

CZECH
SMC Industrial Automation CZ s.r.o.

DENMARK
SMC Pneumatik A/S

ESTONIA
SMC Pneumatics Estonia

FINLAND
SMC Pneumatics Finland OY

FRANCE
SMC Pneumatique S.A.

GERMANY
SMC Pneumatik GmbH

GREEK
SMC Hellas EPE

HUNGARY
SMC Hungary Ipari Automatizálási Kft.

IRELAND
SMC Pneumatics (Ireland) Ltd.

ITALY
SMC Italia S.p.A.

LATVIA
SMC Pneumatics Latvia SIA

LIETUVA
SMC Pneumatics Lietuva, UAB

NETHERLANDS
SMC Pneumatics BV

NORWAY
SMC Pneumatics Norway A/S

POLAND
SMC Industrial Automation Polska Sp.z.o.o.

ROMANIA
SMC Romania S.r.l.

RUSSIA
SMC Pneumatik LLC.

SLOVAKIA
SMC Priemyselna Automatizacia, s.r.o.

SLOVENIA
SMC Industrijska Avtomatika d.o.o.

SPAIN/PORTUGAL
SMC España, S.A.

SWEDEN
SMC Pneumatics Sweden AB

SWITZERLAND
SMC Pneumatik AG

UK
SMC Pneumatics (U.K.) Ltd.

ASIA

CHINA
SMC (China) Co., Ltd.

HONG KONG
SMC Pneumatics (Hong kong) Ltd.

INDIA
SMC Pneumatics (India) Pvt. Ltd.

JAPAN
SMC Corporation

MALAYSIA
SMC Pneumatics (S.E.A.) Sdn. Bhd.

PHILIPPINES
SMC Pneumatics (Philippines), Inc.

SINGAPORE
SMC Pneumatics (S.E.A.) Pte. Ltd.

SOUTH KOREA
SMC Pneumatics Korea Co., Ltd.

TAIWAN
SMC Pneumatics (Taiwan) Co., Ltd.

THAILAND
SMC Thailand Ltd.

NORTH AMERICA

CANADA
SMC Pneumatics (Canada) Ltd.

MEXICO
SMC Corporation (Mexico) S.A. DE C.V.

USA
SMC Corporation of America

SOUTH AMERICA

ARGENTINA
SMC Argentina S.A.

BOLIVIA
SMC Pneumatics Bolivia S.R.L.

BRAZIL
SMC Neumaticos do Brazil Ltda.

CHILE
SMC Pneumatics (Chile) S.A.

VENEZUELA
SMC Neumatica Venezuela S.A.

OCEANIA

AUSTRALIA
SMC Pneumatics (Australia) Pty. Ltd.

NEW ZEALAND
SMC Pneumatics (N.Z.) Ltd.

U.S. & Canadian Sales Offices

EAST

Atlanta
Boston
Charlotte
Nashville
New Jersey
Richmond
Rochester
Tampa

WEST

Austin
Dallas
Los Angeles
Phoenix
Portland
San Francisco

MIDWEST

Chicago
Cincinnati
Cleveland
Detroit
Indianapolis
Milwaukee
Minneapolis
St. Louis

CANADA

Montreal
Tel: (514) 733-9595
Fax: (514) 733-1771

Toronto
Tel: (905) 812-0400
Fax: (905) 812-8686

Vancouver
Tel: (604) 517-1646
Fax: (604) 517-1647

Windsor
Tel: (519) 944-0555
Fax: (519) 944-1870

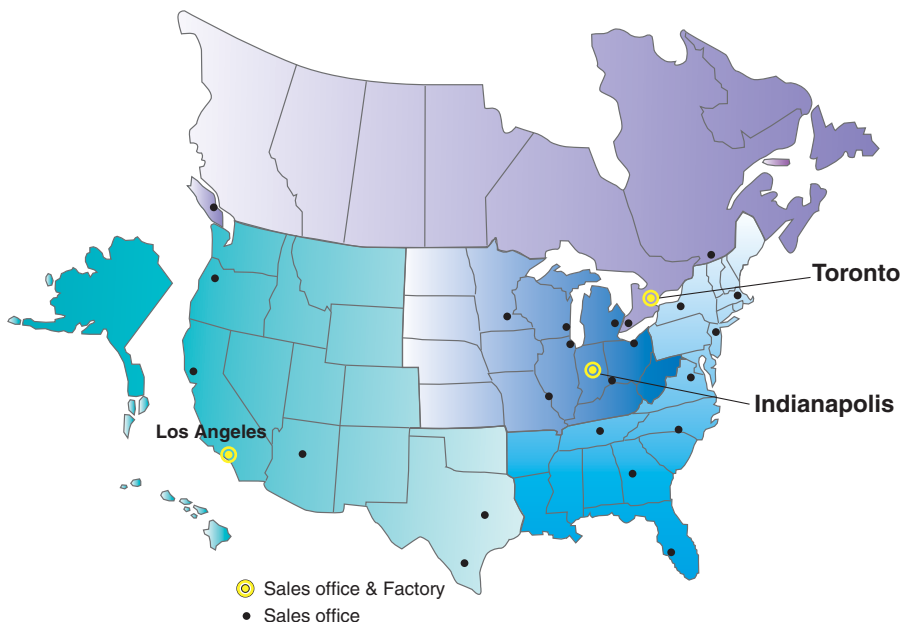

SMC Corporation of America
3011 N. Franklin Road
Indianapolis, IN 46226

(800) 762-7621 (SMC.SMC1)
www.smcusa.com
For International inquires: www.smcworld.com

SMC Pneumatics (Canada) Ltd.
6768 Financial Drive Mississauga
Ontario, L5N 7J6 Canada

(905) 812-0400
www.smc Pneumatics.ca

