

Speed Controller with Uni One-touch Fitting

Series AS

Elbow Type/Universal Type

New-stand male threads for piping that reduces the screw-in time by 1/3.

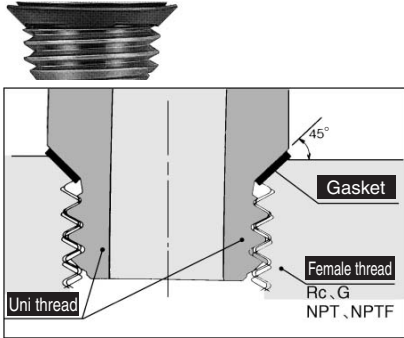

Shape of Uni thread ridge

Use of the chamfered surface of the female thread as the seat surface and adoption of gaskets made by laminating NBR on both surfaces of stainless steel plates achieve secure sealing regardless of the difference of diameters due to the female thread type, deviations due to the tolerance, or the size of the chamfered corner. (Any standard chamfered female thread can be used.)

A ridge shape has been created as a Uni thread for common applications for Rc, G, NPT and NPTF.

The male thread for piping drastically cuts piping man-hours.



JIS Symbol

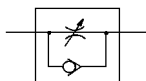

Flow Direction Symbols on Body

	Meter-out type	Meter-in type
Symbol		
JIS Symbol		

Model

Model		Connection thread Uni thread	Applicable tubing O.D.												
Elbow type	Universal type		Metric size					Inch size							
			3.2	4	6	8	10	12	1/8"	5/32"	3/16"	1/4"	5/16"	3/8"	1/2"
AS22□IF-U01	AS23□IF-U01	1/8	●	●	●	●	●*		●	●	●	●	●		
AS22□IF-U02	AS23□IF-U02	1/4		●	●	●				●	●	●	●	●	
AS32□IF-U02	AS33□IF-U02	1/4			●	●	●	●				●	●	●	
AS32□IF-U03	AS33□IF-U03	3/8			●	●	●	●				●	●	●	
AS42□IF-U04	AS43□IF-U04	1/2						●	●					●	●

Note 1) * Elbow type only

Note 2) □ indicates the control type ("0" for meter-out and "1" for meter-in).

Note 3) Models marked with "●" are nickel plated as standard.

Specifications

Fluid	Air
Max. operating pressure	1 MPa
Min. operating pressure	0.1 MPa
Proof pressure	1.5 MPa
Ambient and fluid temperature	-5 to 60°C (No freezing)
Number of needle rotations	10 turns
Applicable tubing material ⁽¹⁾	Nylon, Soft-nylon, Polyurethane
Mounting thread	Uni-thread
Thread seal	Gasket
Option	Hexagon lock nut, Nickel plated ⁽²⁾

Note 1) Use caution regarding the max. operating pressure when soft nylon or polyurethane tubing is used. (Refer to pages 15-6-3 to 15-6-5 for details.)

Note 2) Brass parts are all electroless nickel plated.

Flow Rate and Effective Area

Model		AS22□IF-U01 AS23□IF-U02		AS22□IF-U02 AS23□IF-U02		AS32□IF AS33□IF		AS42□IF-U04 AS43□IF-U04			
Tubing O.D.	Metric size	ø3.2 ø4	ø6, ø8 ø4	ø4	ø6	ø8, ø10	ø6	ø8	ø10 ø12	ø10	ø12
	Inch size	1/8" 5/32"	3/16", 1/4" 5/16"	5/32"	3/16"	1/4", 5/16" 3/8"	1/4"	5/16"	3/8"	3/8"	1/2"
Controlled flow (Free flow)	Flow rate (l/min (ANR))	180	230	260	390	460	660	790	920	1580	1710
	Effective area (mm ²)	2.7	3.7	4	6	7	10	12	14	24	26

Note 1) Flow rate values are measured at 0.5 MPa and 20°C.

Note 2) □ indicates the control type ("0" for meter-out and "1" for meter-in).

AS

ASP

ASN

AQ

ASV

AK

ASS

ASR

ASF

How to Order

AS 2 2 1 1F U02 06 K

Body size

2	1/8, 1/4 standard
3	3/8 standard
4	1/2 standard

Type

2	Elbow
3	Universal

Control type

0	Meter-out
1	Meter-in

With One-touch fitting

Option*

Nil	None
K	Hexagonal lock nut
N	Electroless nickel plated

* If more than one option is required, write option part numbers in the order of "K", "N".

Applicable tubing O.D.

Metric size	Inch size
23	ø3.2*
04	ø4
06	ø6
08	ø8
10	ø10
12	ø12

* Use ø1/8" tube.

Bore size

U01	1/8
U02	1/4
U03	3/8
U04	1/2

Needle Valve/Flow Characteristics

**AS2201F-01, AS2211F-01
AS2301F-01, AS2311F-01**

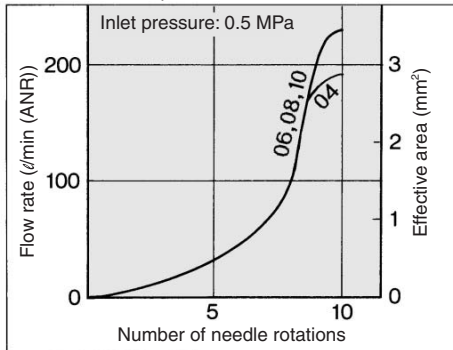

**AS2201F-02, AS2211F-02
AS2301F-02, AS2311F-02**

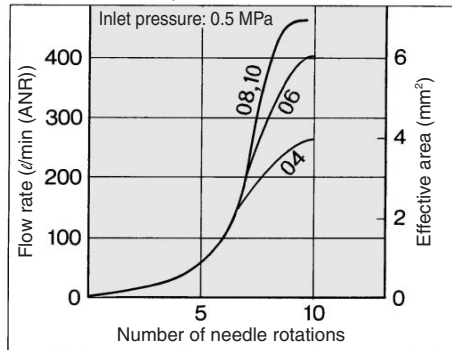

**AS3201F, AS3211F
AS3301F, AS3311F**

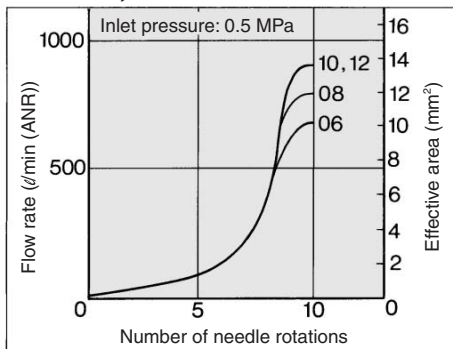

**AS4201F, AS4211F
AS4301F, AS4311F**

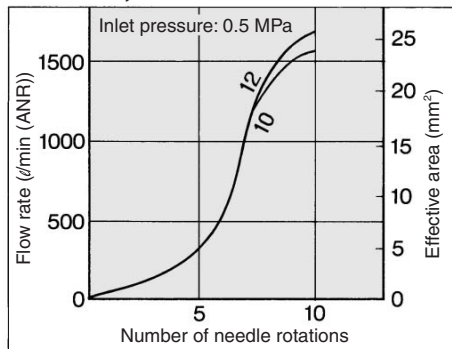

Construction/Component Parts

**Elbow type
Meter-out type**

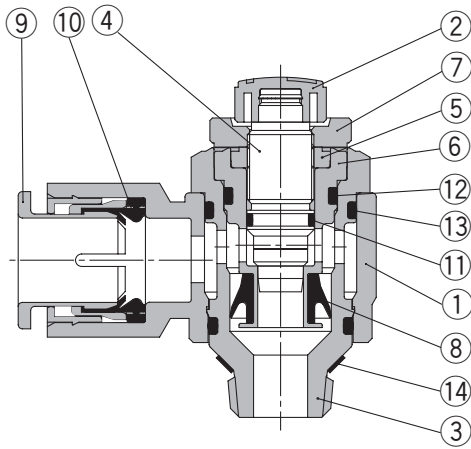

**Universal type
Meter-out type**

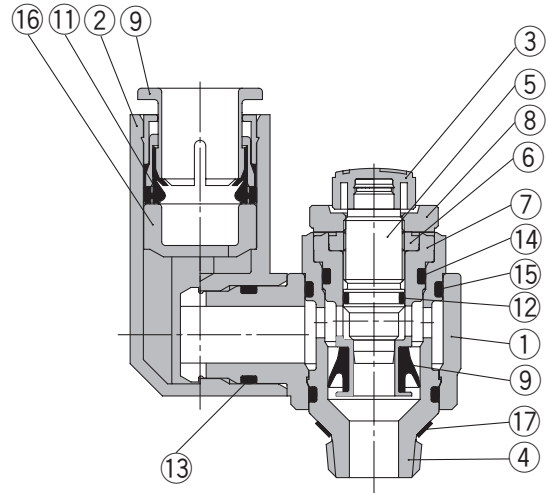

Meter-in type

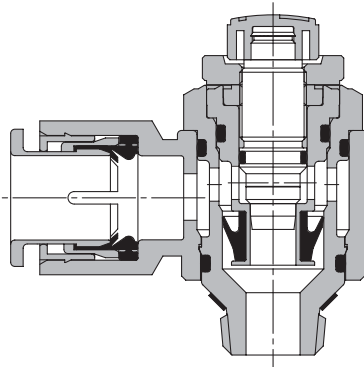

Meter-in type

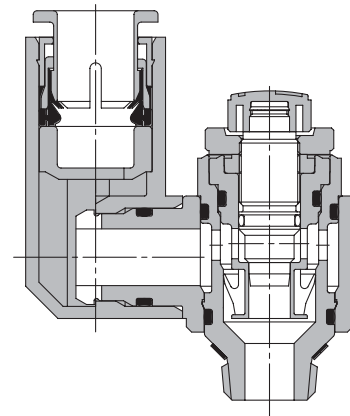

- AS
- ASP
- ASN
- AQ
- ASV
- AK
- ASS
- ASR
- ASF

Component Parts: Elbow Type

No.	Description	Material	Note
①	Body A	PBT	
②	Handle	PBT	
③	Body B	Brass	Electroless nickel plated
④	Needle	Brass	Electroless nickel plated
⑤	Gasket	Stainless steel, NBR	
⑥	Seat ring	Brass	(1)
⑦	Lock nut	Brass ⁽²⁾	Electroless nickel plated ⁽³⁾
⑧	U seal	HNBR	
⑨	Cassette	POM, Stainless steel	
⑩	Seal	NBR	
⑪	O-ring	NBR	
⑫	O-ring	NBR	
⑬	O-ring	NBR	

Note 1) Only AS22□1F-U01 and AS32□1F-U02 are electroless nickel plated.
Note 2) AS22□1F type is made of steel.
Note 3) Meter-in type is black zinc chromate plated.

Component Parts: Universal Type

No.	Description	Material	Note
①	Body A	PBT	
②	Elbow body	PBT	
③	Handle	PBT	
④	Body B	Brass	Electroless nickel plated
⑤	Needle	Brass	Electroless nickel plated
⑥	Gasket	Stainless steel, NBR	
⑦	Seat ring	Brass	(1)
⑧	Lock nut	Brass ⁽²⁾	Electroless nickel plated ⁽³⁾
⑨	U seal	HNBR	
⑩	Cassette	POM, Stainless steel	
⑪	Seal	NBR	
⑫	O-ring	NBR	
⑬	O-ring	NBR	
⑭	O-ring	NBR	
⑮	O-ring	NBR	
⑯	Spacer	PBT ⁽⁴⁾	

Note 1) Only AS22□1F-U01 and AS32□1F-U02 are electroless nickel plated.
Note 2) AS22□1F type is made of steel.
Note 3) Meter-in type is black zinc chromate plated.
Note 4) ø3/16", ø3/8", and ø1/2" are made of brass. AS23□1F-U01(ø3.2, ø4, ø6, ø1/8 and ø5/32) are made of POM.

Series AS



Elbow Type/Metric Size

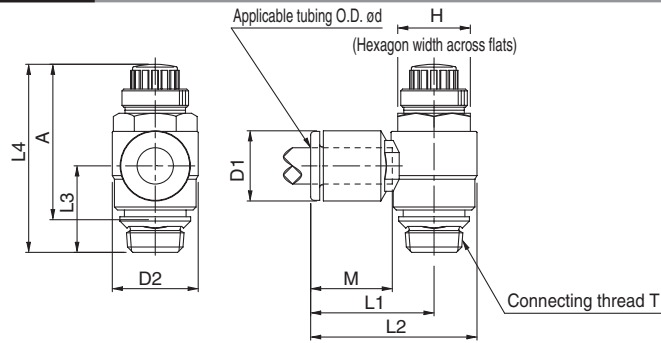

Model	Applicable tubing O.D. ød	T Uni thread	H	D1	D2	L1	L2	L3	L4		A*		M	Weight (g)
									Max.	Min.	Max.	Min.		
AS22□1F-U01-23	3.2	1/8	12	7.8	14.2	20.8	27.9	14.3	36.1	31.1	30.5	25.5	14.5	16.1
AS22□1F-U01-04	4			8.9		21.1	28.2							16.2
AS22□1F-U01-06	6			11.0		22.5	29.6							16.5
AS22□1F-U01-08	8			15.2		25.3	32.4							19.0
AS22□1F-U01-10	10			18.5		33.1	40.2							20.9
AS22□1F-U02-04	4	1/4	17	8.9	18.5	23.3	32.5	17.2	39.4	34.4	32.0	26.6	14.5	31.1
AS22□1F-U02-06	6			11.0		23.9	33.1							31.3
AS22□1F-U02-08	8			15.2		27.2	36.4							33.6
AS22□1F-U02-10	10			18.5		33.9	43.2							35.5
AS32□1F-U02-06	6	1/4	19	11.0	23.0	26.4	37.9	20.3	45.9	40.9	38.1	33.1	15.5	52.5
AS32□1F-U02-08	8			15.2		29.5	41.0							54.9
AS32□1F-U02-10	10			18.5		31.8	43.3							56.8
AS32□1F-U02-12	12			20.9		32.8	44.3							58.4
AS32□1F-U03-06	6	3/8	19	11.0	23.0	26.4	37.9	19.4	45.0	40.0	37.6	32.6	15.5	52.5
AS32□1F-U03-08	8			15.2		29.5	41.0							54.9
AS32□1F-U03-10	10			18.5		31.8	43.3							56.8
AS32□1F-U03-12	12			20.9		32.8	44.3							58.4
AS42□1F-U04-10	10	1/2	24	18.5	28.6	33.6	47.9	22.4	54.6	47.1	44.5	37.0	21.0	93.7
AS42□1F-U04-12	12			20.9		34.6	48.9							95.0

* Reference dimensions of Uni thread after installation.



Universal Type/Metric Size

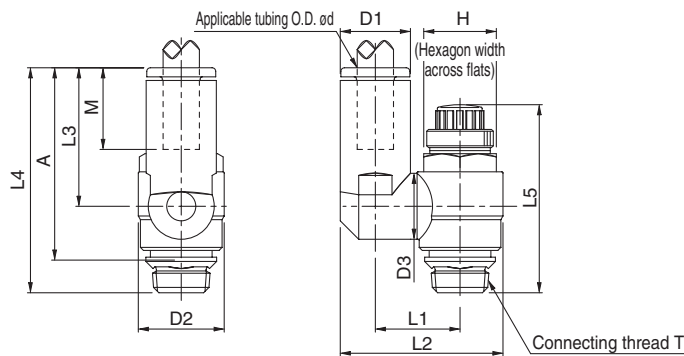

Model	Applicable tubing O.D. ød	T Uni thread	H	D1	D2	D3	L1	L2	L3	L4	L5		A*		M	Weight (g)
											Max.	Min.	Max.	Min.		
AS23□1F-U01-23	3.2	1/8	12	7.8	14.2	9.3	13.4	24.8	18.9	33.2	36.1	31.1	30.5	25.5	14.5	16.9
AS23□1F-U01-04	4			8.9		14.5	27.1	20.6	17.0							
AS23□1F-U01-06	6			11.0		10.9	14.5	27.1	20.6	34.9						17.7
AS23□1F-U01-08	8			15.2		12.9	16.2	30.9	24.7	38.2						20.9
AS23□1F-U02-04	4			1/4		17	8.9	18.5	9.3	15.6						29.2
AS23□1F-U02-06	6	11.0	10.9		16.7		31.4		20.6	37.8	32.4					
AS23□1F-U02-08	8	15.2	12.9		18.3		35.2		24.4	40.8	35.7					
AS23□1F-U02-10	10	18.5	19.6		38.1		26.8		43.2	39.2						
AS33□1F-U02-06	6	1/4	19	11.0	23.0	10.9	18.9	35.9	20.6	42.5	45.9	40.9	38.1	33.1	15.5	53.6
AS33□1F-U02-08	8			15.2		12.9	20.6	39.7	24.4	43.7						56.9
AS33□1F-U02-10	10			18.5		16.2	22.5	43.3	28.3	48.6						60.4
AS33□1F-U02-12	12			20.9		23.5	45.5	29.3	49.6	62.2						
AS33□1F-U03-06	6	3/8	19	11.0	23.0	10.9	18.9	35.9	20.6	41.6	45.0	40.0	37.6	32.6	15.5	53.6
AS33□1F-U03-08	8			15.2		12.9	20.6	39.7	24.4	42.8						56.9
AS33□1F-U03-10	10			18.5		16.2	22.5	43.3	28.3	47.7						60.4
AS33□1F-U03-12	12			20.9		23.5	45.5	29.3	48.7	62.2						
AS43□1F-U04-10	10	1/2	24	18.5	28.6	16.2	25.3	48.9	28.3	50.7	54.6	47.1	44.5	37.0	21.0	97.1
AS43□1F-U04-12	12			20.9		19.4	26.8	51.6	30.8	53.2						99.8

* Reference dimensions of Uni thread after installation.

Speed Controller with Uni One-touch Fitting Elbow Type/Universal Type **Series AS**



Elbow Type/Inch Size

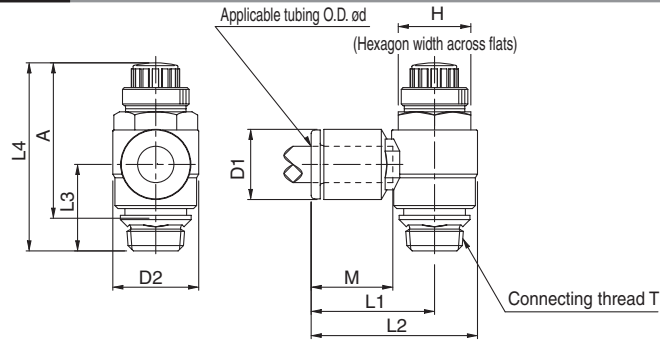

Model	Applicable tubing O.D.ød	T Uni thread	H	D1	D2	L1	L2	L3	L4		A*		M	Weight (g)
									Max.	Min.	Max.	Min.		
AS22□1F-U01-01	1/8"	1/8	12	7.8	14.2	20.8	27.9	14.3	36.1	31.1	30.5	25.5	14.5	16.1
AS22□1F-U01-03	5/32"			8.9		21.1	28.2							16.2
AS22□1F-U01-05	3/16"			11.4		23.1	30.2							17.5
AS22□1F-U01-07	1/4"			13.2		23.9	31.0							18.1
AS22□1F-U01-09	5/16"			15.2		25.3	32.4							19.0
AS22□1F-U02-03	5/32"	1/4	17	8.9	18.5	23.3	32.5	17.2	39.4	34.4	32.0	26.6	14.5	31.1
AS22□1F-U02-05	3/16"			11.4		24.9	34.2							32.4
AS22□1F-U02-07	1/4"			13.2		25.2	34.5							32.9
AS22□1F-U02-09	5/16"			15.2		27.2	36.4							33.6
AS22□1F-U02-11	3/8"			17.9		33.9	43.2							35.3
AS32□1F-U02-07	1/4"	1/4	19	13.2	23.0	27.8	39.3	20.3	45.9	40.9	38.1	33.1	17.0	53.9
AS32□1F-U02-09	5/16"			15.2		29.5	41.0							54.9
AS32□1F-U02-11	3/8"			17.9		31.8	43.3							56.6
AS32□1F-U03-07	1/4"	3/8	19	13.2	23.0	27.8	39.3	19.4	45.0	40.0	37.6	32.6	17.0	53.9
AS32□1F-U03-09	5/16"			15.2		29.5	41.0							54.9
AS32□1F-U03-11	3/8"			17.9		31.8	43.3							56.6
AS42□1F-U04-11	3/8"	1/2	24	17.9	18.6	33.6	47.9	22.4	54.6	47.1	44.5	37.0	21.0	93.6
AS42□1F-U04-13	1/2"			21.4		35.2	49.5							95.4



Universal Type/Inch Size

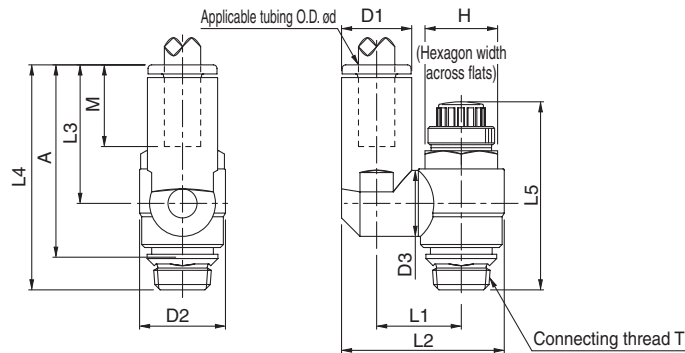

Model	Applicable tubing O.D.ød	T Uni thread	H	D1	D2	D3	L1	L2	L3	L4	L5		A*		M	Weight (g)
											Max.	Min.	Max.	Min.		
AS23□1F-U01-01	1/8"	1/8	12	7.8	14.2	9.3	13.4	24.8	18.9	33.2	36.1	31.1	30.5	25.5	14.5	16.9
AS23□1F-U01-03	5/32"			8.9		10.3	14.2	27.0	21.5	35.9						17.0
AS23□1F-U01-05	3/16"			11.4		11.4	15.2	28.9	22.3	36.3						19.4
AS23□1F-U01-07	1/4"			13.2		12.9	16.2	30.9	24.7	38.2						20.9
AS23□1F-U01-09	5/16"			15.2		12.9	16.2	30.9	24.7	38.2						20.9
AS23□1F-U02-03	5/32"	1/4	17	8.9	18.5	9.3	15.6	29.2	18.9	36.1	39.4	34.4	32.0	26.6	14.5	31.7
AS23□1F-U02-05	3/16"			11.4		10.3	16.4	31.1	21.5	38.8						33.2
AS23□1F-U02-07	1/4"			13.2		11.4	17.4	33.2	22.3	39.5						33.9
AS23□1F-U02-09	5/16"			15.2		12.9	18.3	35.2	24.4	40.8						35.7
AS23□1F-U02-11	3/8"			17.9		12.9	19.6	38.1	26.8	43.2						39.0
AS33□1F-U02-07	1/4"	1/4	19	13.2	23.0	11.4	19.6	37.7	22.3	44.2	45.9	40.9	38.1	33.1	17.0	55.4
AS33□1F-U02-09	5/16"			15.2		12.9	20.6	39.7	24.4	43.7						56.9
AS33□1F-U02-11	3/8"			17.9		16.2	22.5	42.9	28.3	48.6						60.2
AS33□1F-U03-07	1/4"	3/8	19	13.2	23.0	11.4	19.6	37.7	22.3	43.3	45.0	40.0	37.6	32.6	17.0	55.4
AS33□1F-U03-09	5/16"			15.2		12.9	20.6	39.7	24.4	42.8						56.9
AS33□1F-U03-11	3/8"			17.9		16.2	22.5	42.9	28.3	47.7						60.2
AS43□1F-U04-11	3/8"	1/2	24	17.9	28.6	16.2	25.3	48.6	28.3	50.7	54.6	47.1	44.5	37.0	21.1	96.4
AS43□1F-U04-13	1/2"			21.7		19.4	26.8	52.5	30.8	53.2						99.9

* Reference dimensions of Uni thread after installation.

AS

ASP

ASN

AQ

ASV

AK

ASS

ASR

ASF