

# Series ARX20

## Construction

JIS Symbol

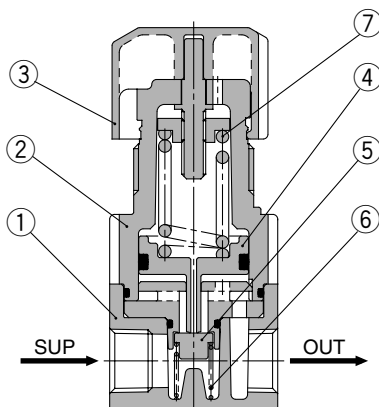
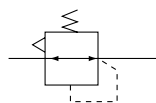

### Component Parts

No.	Description	Material	Note
①	Body	ADC	
②	Bonnet	POM	

### Replacement Parts

No.	Description	Material	Part no.
③	Handle	POM	1348102#1
④	Piston assembly	POM, NBR	1348104A
⑤	Valve	Brass, NBR	1348105
⑥	Valve spring	Stainless steel	1348109
⑦	Adjusting spring	Steel wire	1348108 (For 0.85 MPa) 1348108-1 (For 0.3 MPa)

## Dimensions

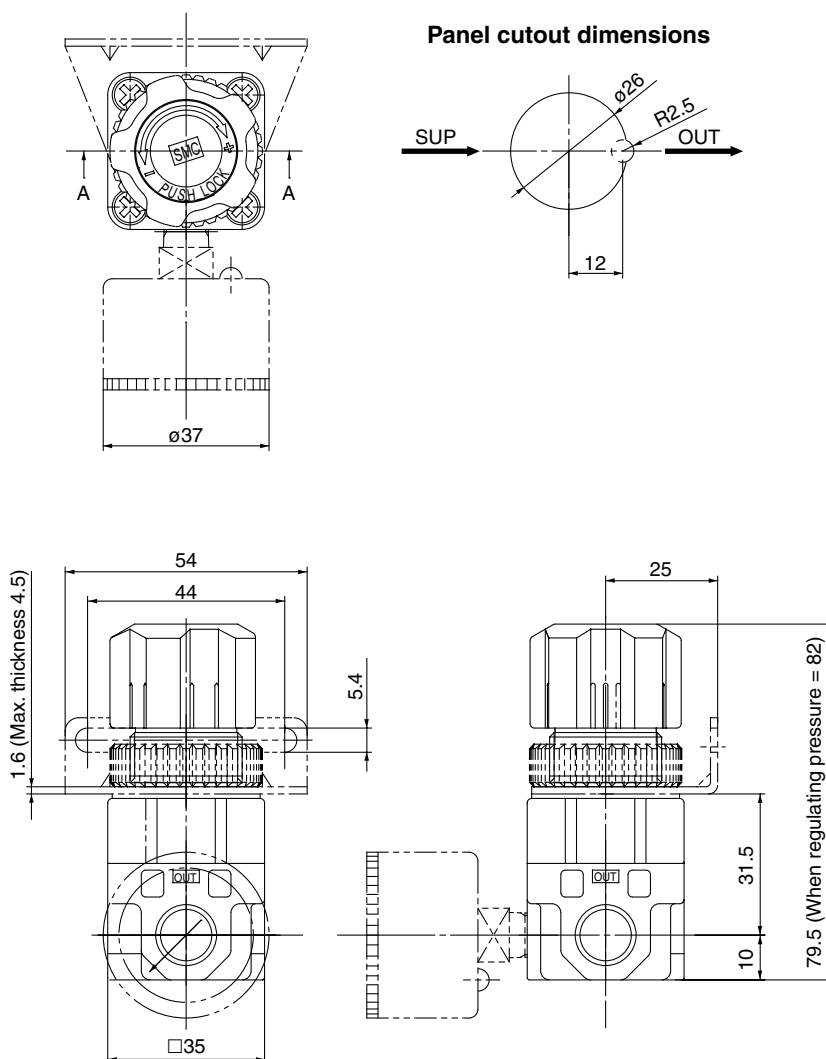

## Option

### Panel Nut

Part no.	1348110A
Material	POM, NBR (Gasket)

### Dimensions

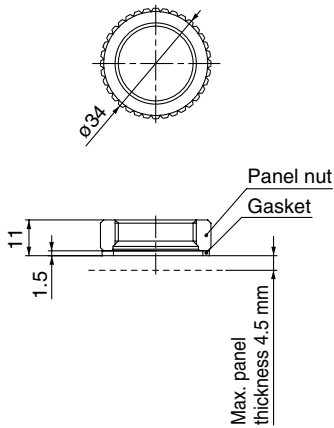

### Bracket

Part no.	1348112
Material	SPCC (Black zinc chromated)

### Dimensions

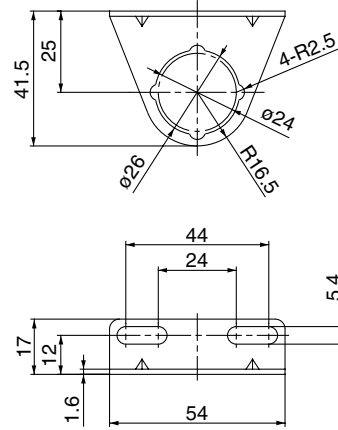

\* Install the gasket underneath the panel and bracket (bonnet side).  
Tighten the panel nut by hand without the use of tools.

## ⚠ Precautions

Be sure to read before handling. Refer to pages 14-21-3 to 14-21-4 for Safety Instructions and Common Precautions.

### Design and Selection

#### ⚠ Warning

##### 1. Confirm the regulating pressure range.

Be sure to install safety devices in locations where output pressure above the regulating pressure range can lead to damage or malfunction of equipment in the outlet pressure side.

##### 2. Residual pressure relief without supply pressure.

In cases where the supply pressure is removed with the downstream pressure in a low pressure setting state, it may not be possible to eliminate the downstream pressure (residual pressure relief). Provide a residual pressure relief circuit for cases in which reliable elimination of downstream pressure must be performed.

### Mounting

#### ⚠ Caution

##### 1. To set the correct pressure

- 1) Set the pressure by increasing from a lower pressure to the desired setting, and lock the handle after the pressure is set.
- 2) Make connections after confirming the "SUP" mark which indicates the air inlet. Reversed connections will cause malfunction.

F.R.L.

AV

AU

AF

AR

IR

VEX

AMR

ITV

IC

VBA

VE□

VY1

G

PPA

AL