

## INLINE® Enclosures

### INLINE®, Type 4



#### Industry Standards

Mounting brackets required to meet UL/CSA external mounting requirements.

UL 508A Listed; Type 3, 4, 12; File No. E61997 cUL Listed per CSA C22.2 No. 94; Type 3, 4, 12; File No. E61997
---

NEMA/EEMAC Type 4 and 12  
CSA, File No. 42186: Type 4 and 12  
IEC 60529, IP66

#### Application

Aesthetic styling, with an attractive, durable light-gray finish, makes INLINE® Enclosures an excellent choice when style and functionality are important. INLINE Enclosures have an outward formed flange to prevent contaminants from entering the enclosure and are available in three versions: window door, hinged solid door and solid screw cover.

#### Specifications

- Metric dimensions
- 1.4-mm (16 gauge) steel
- Seams continuously welded and ground smooth
- External formed body flange
- Large perimeter body opening
- Fastening holes in back of body for direct mounting or optional external mounting brackets
- Seamless foam-in-place gasket
- Grounding stud on the body
- Bonding provision on the cover or door
- Furnished hardware kit includes panel mounting screws, grounding hardware and sealing washers for wall-mounting holes
- Installation instructions

#### INLINE Screw-Cover Enclosures

- Captivated cover screws with sealing bushings

#### INLINE Hinged-Door Enclosures

- 180-degree door opening
- Removable hinge pins
- Self-grounding, slotted quarter-turn latch

#### INLINE Window-Door Enclosures

- Flush-mounted 4.8-mm (3/16-in.) clear polycarbonate window
- 180-degree door opening
- Removable hinge pins
- Self-grounding, slotted quarter-turn latch

#### Finish

RAL 7035 textured light-gray polyester powder paint inside and out

#### Accessories

See also Accessories.

DIN Rail or Panel-Mounting Brackets  
DIN3 Rails  
Lock Inserts  
Mounting-Bracket Kit  
Panels for Junction Boxes  
Wing Knob Latch

#### Modification and Customization

Hoffman excels at modifying and customizing products to your specifications. Contact your local Hoffman sales office or distributor for complete information.

Bulletin: A54

# INLINE® Enclosures

## Standard Product INLINE Screw-Cover Enclosures

Catalog Number	AxBxC in./mm	Panel	Conductive Panel	Panel Size D x E mm/in.	Mounting G x H mm/in.	F mm/in.
LSC151512	5.91 x 5.91 x 4.72	LP1515	LP1515G	131 x 131	132 x 85	105
	150 x 150 x 120			5.16 x 5.16	5.18 x 3.36	4.13
LSC201512	7.87 x 5.91 x 4.72	LP2015	LP2015G	181 x 131	182 x 85	105
	200 x 150 x 120			7.13 x 5.16	7.15 x 3.36	4.13
LSC252015	9.84 x 7.87 x 5.91	LP2520	LP2520G	231 x 181	232 x 135	135
	250 x 200 x 150			9.09 x 7.13	9.12 x 5.33	5.31
LSC302515	11.81 x 9.84 x 5.91	LP3025	LP3025G	281 x 231	281 x 185	135
	300 x 250 x 150			11.06 x 9.09	11.08 x 7.30	5.31
LSC353020	13.78 x 11.81 x 7.87	LP3530	LP3530G	331 x 281	331 x 235	185
	350 x 300 x 200			13.03 x 11.06	13.05 x 9.27	7.28

Purchase panels separately.

INLINE Screw Cover Enclosure

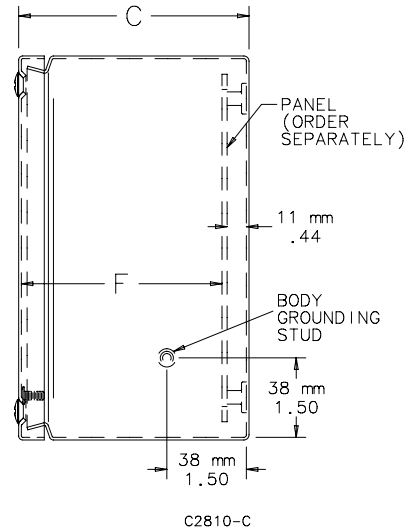
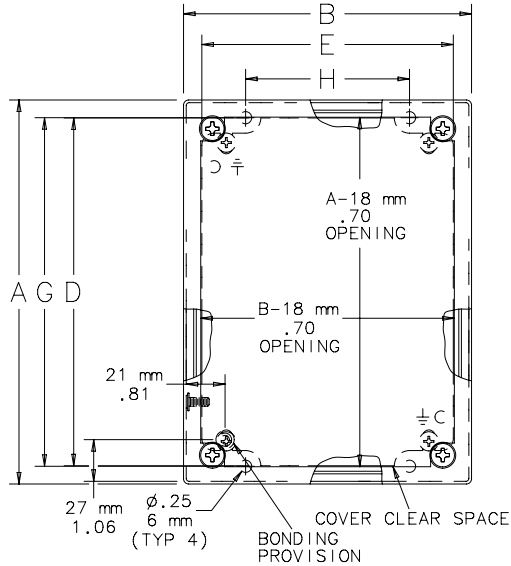

NOTE: Rear mounting holes will accommodate M6-1.0 or 1/4-20 UNC mounting screws (supplied by customer)

# INLINE® Enclosures

## Standard Product INLINE Hinged-Door Enclosures

Catalog Number	AxBxC in./mm	Panel	Conductive Panel	Panel Size D x E mm/in.	Mounting G x H mm/in.	F mm/in.
LHC151512	5.91 x 5.91 x 4.72	LP1515	LP1515G	131 x 131	132 x 85	105
	150 x 150 x 120			5.16 x 5.16	5.18 x 3.36	4.13
LHC201512	7.87 x 5.91 x 4.72	LP2015	LP2015G	181 x 131	182 x 85	105
	200 x 150 x 120			7.13 x 5.16	7.15 x 3.36	4.13
LHC252015	9.84 x 7.87 x 5.91	LP2520	LP2520G	231 x 181	232 x 135	135
	250 x 200 x 150			9.09 x 7.13	9.12 x 5.33	5.31
LHC302515	11.81 x 9.84 x 5.91	LP3025	LP3025G	281 x 231	281 x 185	135
	300 x 250 x 150			11.06 x 9.09	11.08 x 7.30	5.31
LHC353020	13.78 x 11.81 x 7.87	LP3530	LP3530G	331 x 281	331 x 235	185
	350 x 300 x 200			13.03 x 11.06	13.05 x 9.27	7.28

Purchase panels separately.

INLINE Hinged Door and Window Door Enclosures

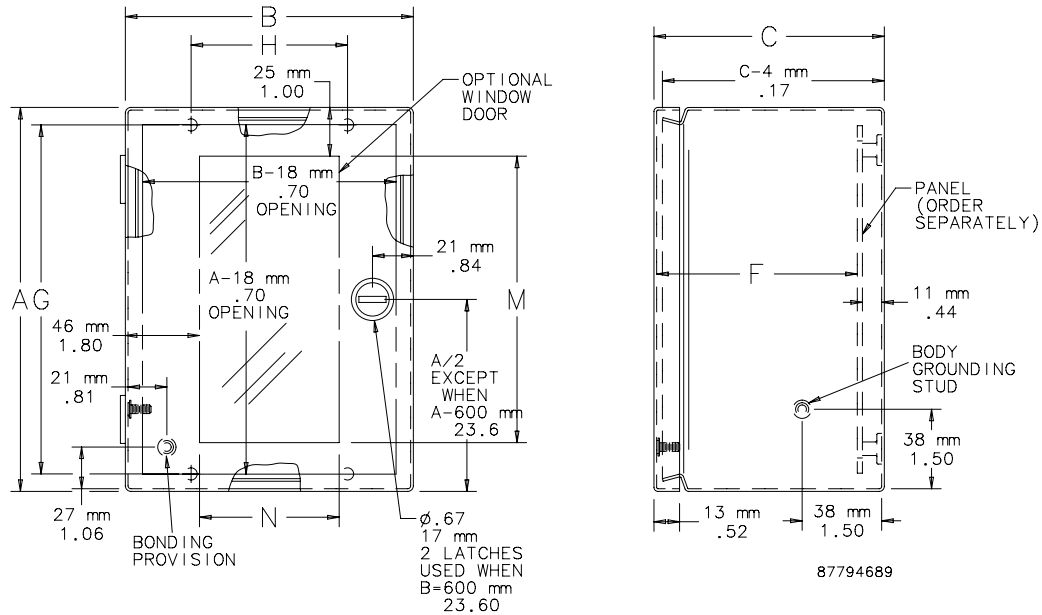

## INLINE® Enclosures

### Standard Product **INLINE Window-Door Enclosures**

Catalog Number	AxBxCin./mm	Panel	Conductive Panel	Panel Size D x E mm/in.	Mounting G x H mm/in.	Window Size M x N mm/in.	F mm/in.
<b>LWC201512</b>	7.87 x 5.91 x 4.72	LP2015	LP2015G	181 x 131	182 x 85	149 x 65	101
	200 x 150 x 120			7.13 x 5.16	7.15 x 3.36	5.87 x 2.31	3.98
<b>LWC252015</b>	9.84 x 7.87 x 5.91	LP2520	LP2520G	231 x 181	232 x 135	199 x 115	131
	250 x 200 x 150			9.09 x 7.13	9.12 x 5.33	7.83 x 4.24	5.16
<b>LWC302515</b>	11.81 x 9.84 x 5.91	LP3025	LP3025G	281 x 231	281 x 185	249 x 165	131
	300 x 250 x 150			11.06 x 9.09	11.08 x 7.30	9.80 x 6.25	5.16
<b>LWC204015</b>	7.87 x 15.75 x 5.91	LP2040	LP2040G	181 x 381	182 x 335	115 x 349	131
	200 x 400 x 150			7.13 x 15.00	7.15 x 13.20	4.53 x 13.49	5.16
<b>LWC206015</b>	7.87 x 23.62 x 5.91	LP2060	LP2060G	181 x 581	182 x 535	115 x 549	131
	200 x 600 x 150			7.13 x 21.06	7.15 x 21.08	4.53 x 21.36	5.16

Purchase panels separately.

LWC204015 and LWC206015 are hinged on "B" side of enclosure.

INLINE Hinged Door and Window Door Enclosures

