

A01 series

Pushbutton switches & indicators

Distinctive features and specifications

A01_AX1607US



- ❑ Panel Sealed to IP65
- ❑ Single pole to four pole changeover
- ❑ Custom engraving or film legends options
- ❑ Push on tab terminals
- ❑ 6A 250VAC

ELECTRICAL SPECIFICATIONS

- **Current/Voltage Rating** : 10mA 5VAC min, 6A 250VAC, 6Amp 12VDC
- **Initial Contact Resistance** : 10mΩ max at 1A 4VDC
- **Insulation Resistance** : 50MΩ min
- **Dielectric Strength** : 750V between open contacts, 5KV live to accessible
- **Electrical Life** : 50,000 cycles min
- **Contact Gap** : >1mm (0.039)
- **Insulation** : Class 2
- **Lamp Life** : LED, 60,000 hours to 75% relative luminosity filament, approx. 5000 hours neon, approx. 10,000 hours

MECHANICAL SPECIFICATIONS

- **Mechanical Life** : (operator) Momentary, 1 million cycles, maintained 100,000 cycles
- **Lamp** : Midget grove T1 ¾ filament, neon or LED
- **Terminals** : Solder/quick connect 2.8mm (0.110)

GENERAL SPECIFICATIONS

- **Operating Temperature** : -20°C to +55°C
- **Solder Heat Resistance** : 350°C for 5 seconds
- **Sealing** : Panel sealed to IP65, rear of panel IP40

AGENCY APPROVALS



PANEL CUT OUT

Round & Square bezel operators only

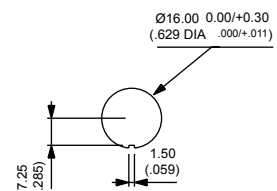

Rectangular bezel operators only

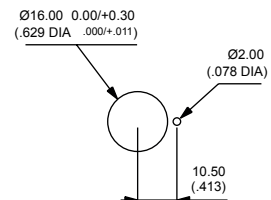

Max panel thickness 8mm (0.314)

MATERIALS

- **Screens** : PC
- **Reflector Assembly** : PC
- **Operator** : PBT
- **Nut** : ABS
- **Camtrack Momentary** : PPE
- **Camtrack Maintained** : PPSU
- **Switch Block 1 & 2 Pole** : PBT
- **Switch Block 3 & 4 Pole** : PEI
- **Contacts** : Gold plated silver



Dimensions : first dimensions are in mm while inches are shown in brackets. Refer to the following pages for further information.



Mounting accessories : standard hardware 1 nut and 1 sealing washer.

A01 series

Pushbutton switches & indicators

Panel cut-out $\varnothing 16$ (0.755)

Pushbutton

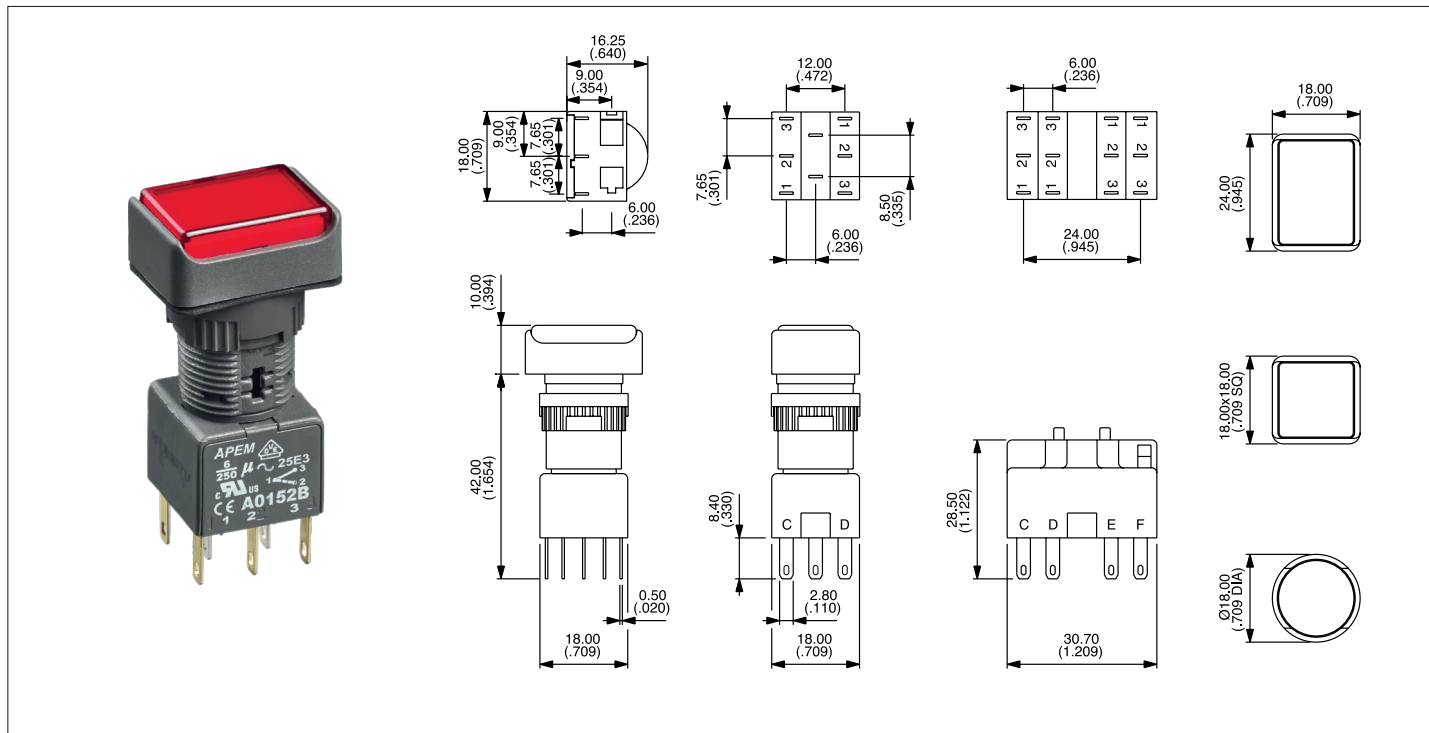

Indicator

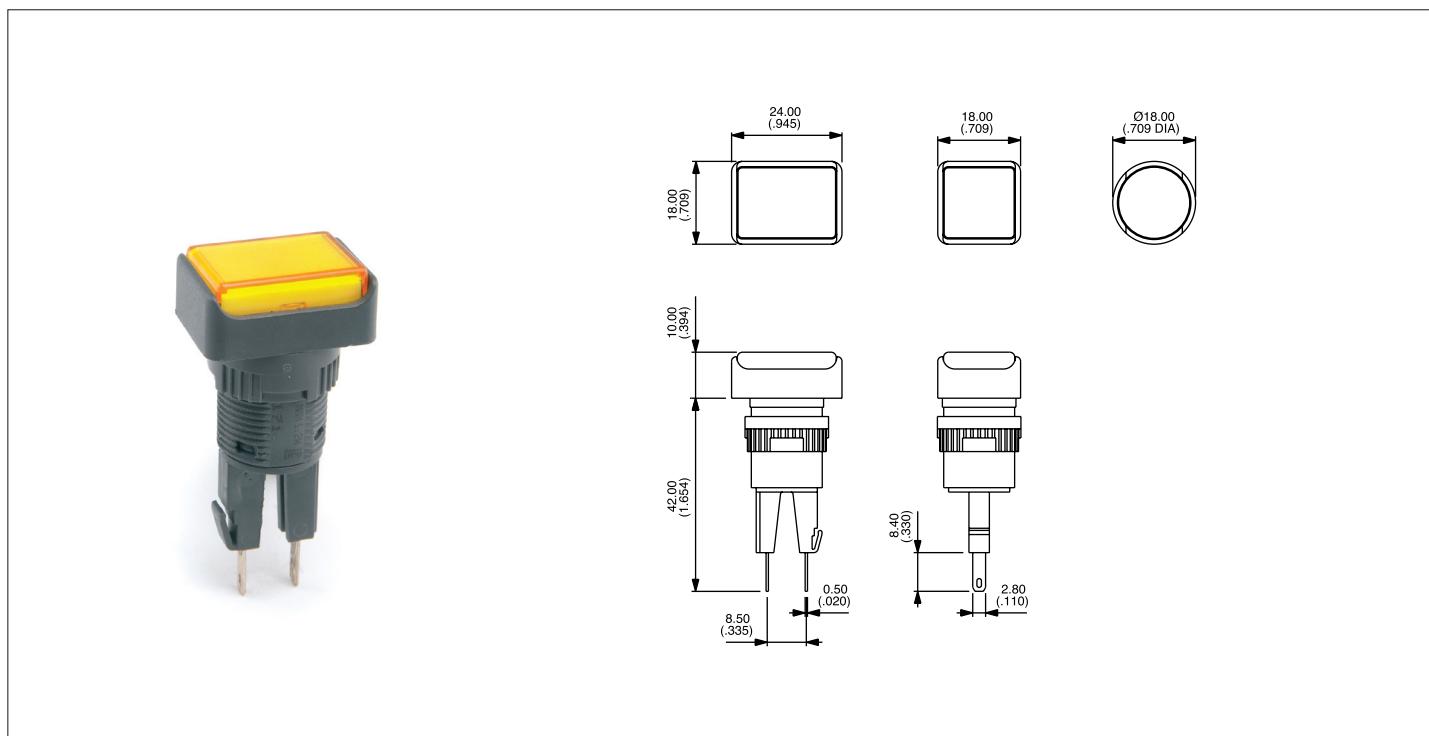

A01 series

Pushbutton switches & indicators

Overview

Pushbutton

Screen			+	Lamp <small>(if required)</small>		+	Operator		+	Switch block	
Bezel	Colour	Part No	Lamp	Voltage	Part No	Pole	Bezel	Description	Part No	No of poles	Part No
	black	A0161A	Filament	6.3V	A0141A	1 or 2		llum, momentary	A0101Y	Single pole	A0151B
	red	A0161B	Filament	14V	A0141B	1 or 2		llum, maintained	A0101X	Double pole	A0152B
	amber	A0161C	Filament	28V	A0141C	1 or 2		Non-illum, momentary	A0102Y	Three pole	A0155B
	yellow	A0161D	Filament	36V	A0141D	1 or 2		Non-illum, maintained	A0102X	Four pole	A0153B
	green	A0161E	Filament	48V	A0141E	3 or 4		llum, momentary	A0103Y		
	blue	A0161F	Filament	60V	A0141F	3 or 4		llum, maintained	A0103X		
	clear	A0161G	Neon	110V	A0143G	3 or 4		Non-illum, momentary	A0104Y		
	white	A0161J	Neon	220V	A0143H	3 or 4		Non-illum, maintained	A0104X		
	black	A0162A	LED	6V red	A0142L1	1 or 2		llum, momentary	A0105Y		
	red	A0162B	LED	6V green	A0142L2	1 or 2		llum, maintained	A0105X		
	amber	A0162C	LED	6V amber	A0142L3	1 or 2		Non-illum, momentary	A0106Y		
	yellow	A0162D	LED	12V red	A0142M1	1 or 2		Non-illum, maintained	A0106X		
	green	A0162E	LED	12V green	A0142M2	3 or 4		llum, momentary	A0107Y		
	blue	A0162F	LED	12V amber	A0142M3	3 or 4		llum, maintained	A0107X		
	clear	A0162G	LED	12V blue	A0142M4	3 or 4		Non-illum, momentary	A0108Y		
	white	A0162J	LED	12V white	A0142M5	3 or 4		Non-illum, maintained	A0108X		
	black	A0163A	LED	24V red	A0142N1	1 or 2		llum, momentary	A0109Y		
	red	A0163B	LED	24V green	A0142N2	1 or 2		llum, maintained	A0109X		
	amber	A0163C	LED	24V amber	A0142N3	1 or 2		Non-illum, momentary	A0110Y		
	yellow	A0163D	LED	24V blue	A0142N4	1 or 2		Non-illum, maintained	A0110X		
	green	A0163E	LED	24V white	A0142N5	3 or 4		llum, momentary	A0111Y		
	blue	A0163F	LED	48V red	A0142P1	3 or 4		llum, maintained	A0111X		
	clear	A0163G	LED	48V green	A0142P2	3 or 4		Non-illum, momentary	A0112Y		
	white	A0163J	LED	48V amber	A0142P3	3 or 4		Non-illum, maintained	A0112X		

Bezel: rectangular square round. 'llum' - illuminated, 'Non-illum' - non illuminated

Indicator

Screen			+	Lamp		+	Operator	
Bezel	Colour	Part No	Lamp	Voltage	Part No	Bezel	Description	Part No
	black	A0161A	Filament	6.3V	A0141A		Indicator	A0171
	red	A0161B	Filament	14V	A0141B		Indicator	A0172
	amber	A0161C	Filament	28V	A0141C		Indicator	A0173
	yellow	A0161D	Filament	36V	A0141D			
	green	A0161E	Filament	48V	A0141E			
	blue	A0161F	Filament	60V	A0141F			
	clear	A0161G	Neon	110V	A0143G			
	white	A0161J	Neon	220V	A0143H			
	black	A0162A	LED	6V red	A0142L1			
	red	A0162B	LED	6V green	A0142L2			
	amber	A0162C	LED	6V amber	A0142L3			
	yellow	A0162D	LED	12V red	A0142M1			
	green	A0162E	LED	12V green	A0142M2			
	blue	A0162F	LED	12V amber	A0142M3			
	clear	A0162G	LED	12V blue	A0142M4			
	white	A0162J	LED	12V white	A0142M5			
	black	A0163A	LED	24V red	A0142N1			
	red	A0163B	LED	24V green	A0142N2			
	amber	A0163C	LED	24V amber	A0142N3			
	yellow	A0163D	LED	24V blue	A0142N4			
	green	A0163E	LED	24V white	A0142N5			
	blue	A0163F	LED	48V red	A0142P1			
	clear	A0163G	LED	48V green	A0142P2			
	white	A0163J	LED	48V amber	A0142P3			

Bezel: rectangular square round.



Unsealed switches & indicators (IP40) suffix 01 to the end of the part number.
Screen engraving insertable legends, & bi-color LED's please contact APEM

A01 series Pushbutton switches & indicators

Accessories

Flush mount bezels

Dark grey plastic material – supplied with sealing washer

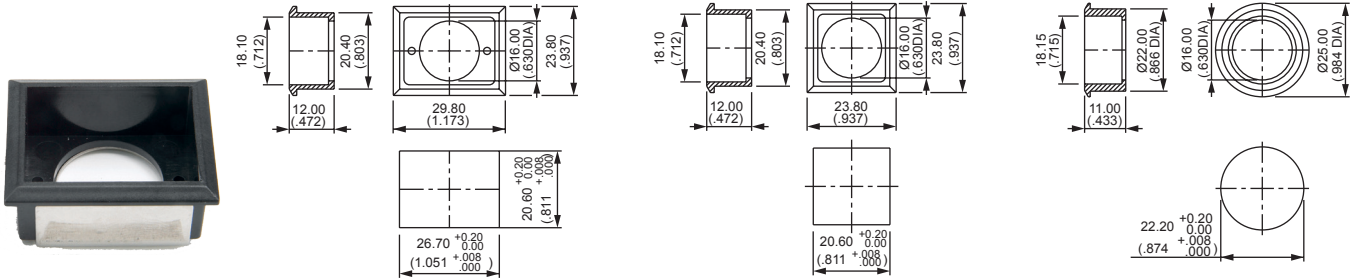

Rectangular : A01FM1

Square : A01FM

Round : A01FM2

Anodised aluminium/matt black

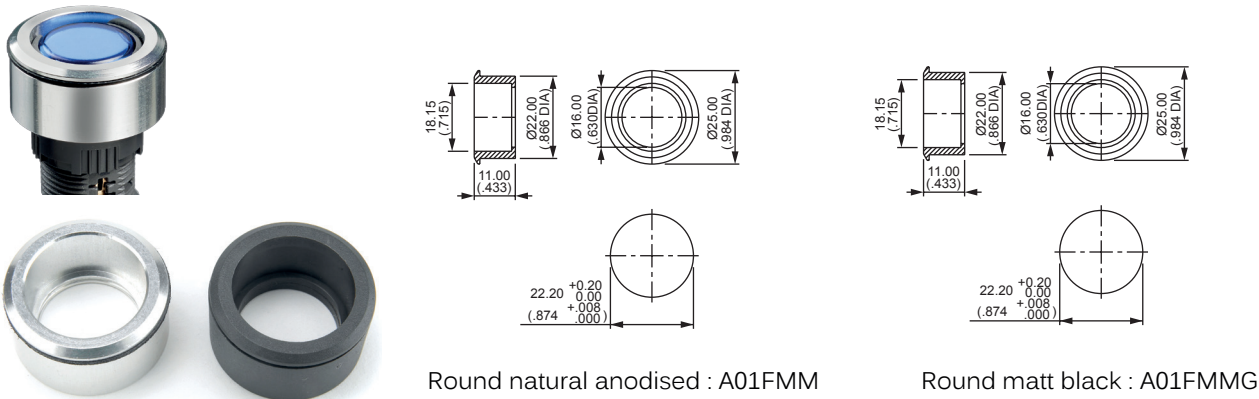

Round natural anodised : A01FMM

Round matt black : A01FMMG

PCB Sockets

Number of Poles

Part No.

Single pole, non illuminated :	A01PC1
Double pole, non illuminated :	A01PC2
Single pole, illuminated :	A01PC3
Double pole, illuminated :	A01PC4
Indicator :	A01PC5

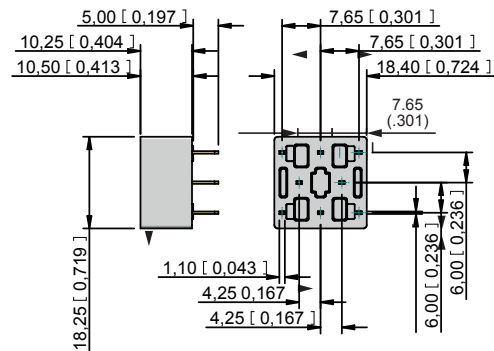

Dimensions : first dimensions are in mm while inches are shown in brackets.
Refer to the following pages for further information.

A01 series

Pushbutton switches & indicators

Accessories

Flap guards

Technical drawings for flap guards:

- To fit rectangular bezel : A01FG1**
 - Top view: 24.00 (.945) width, 13.50 (.531) height.
 - Side view: 12.00 (.472) height, 24.00 (.945) width.
 - Bottom view: 13.65 (.537) width.
- To fit round & Square bezel: A01FM2**
 - Top view: 24.00 (.945) width, 13.50 (.531) height.
 - Side view: 9.00 (.354) height, 24.00 (.945) width.
 - Bottom view: 13.65 (.537) width, 18.00 (.708) height.

Aluminium bezel protection guards

Technical drawings for aluminium bezel protection guards:

- Rectangular : A01MG1**
 - Top view: 18.00 (.708) width, 24.00 (.944) height, Ø2.00 (Ø.078DIA) hole.
 - Side view: 12.00 (.472) height, 10.15 (.398) depth.
 - Bottom view: Ø16.00 (Ø.630DIA) hole.
- Square : A01MG**
 - Top view: 18.00 (.708) width, 18.20 (.717) height.
 - Side view: 12.00 (.472) height.
 - Bottom view: Ø16.00 (Ø.630DIA) hole.
- Round natural anodised: A01MG2**
Matt black : A01MG2G
 - Top view: Ø19.60 outer diameter, Ø18.10 inner diameter, Ø16.05 hole diameter.
 - Side view: 9.00 height, 10.00 depth.

Anti rotation ring

Technical drawing for anti rotation ring (A01LW):

- Top view: 18.00 (.708) width, 14.75 (.580) height, Ø16.00 (Ø.629DIA) hole.
- Side view: 2.00 (.078) height.

A01LW

Blanking plugs

Technical drawings for blanking plugs:

- Rectangular : A0131**
 - Top view: 24.0 (.946) width, 18.0 (.709) height.
- Square : A0132**
 - Top view: 18.0 (.709) width, 18.0 (.709) height.
- Round : A0133**
 - Top view: Ø18.0 (.709 DIA) diameter.

A01 series

Pushbutton switches & indicators

Installation & tools

Installation guide

SWITCH BLOCK ASSEMBLY

To assemble switch block to the operator, firstly, take care to line up the switch block with the back of the operator. Once in position slide on to the back of the operator. N.B. Ensure latch is fully engaged correctly onto the switch block. To remove switch block, depress the latch and slide the switch block off the operator.

PANEL MOUNTING ASSEMBLY

- Drill/punch hole shaped as shown on page one.
- Assemble front operator through hole, fit fixing nut and tighten to a maximum torque of 0.8Nm using tool No. 30-0001.
- Wire chosen switch block as required and slide onto operator until latch engages.
- Fit bulb if required using tool No. 30-0002.
- Snap screen onto reflector assembly with legend in between if required and snap onto front operator, take care to line up the locating slot with the polarising dot and not to damage the internal seal
- To place/remove the bulb use the bulb extractor 30-0002.

Tools

