

E5-648-C242x

electronic preset counter with two presets



EAT•N

Powering Business Worldwide

Contents

Description	Page	Description	Page
1. Preface	3	8. Error message	13
2. Safety instructions and warnings	3	9. Connections	13
2.1 Use according to the intended purpose	3	9.1 Signal and control inputs	14
2.2 Mounting in a control panel	3	9.2 Supply voltage and outputs	14
2.3 Electrical installation	3	10. Technical data	14
3. Description	3	10.1 General data	14
4. Display/Operating elements	4	10.2 Pulse counter	14
5. Inputs	4	10.3 Tacho/frequency meter	14
5.1 INP A, INP B	4	10.4 Timer	14
5.2 Reset	4	10.5 Signal and control inputs	14
5.3 Gate	4	10.6 Outputs	15
5.4 Lock input	4	10.7 Supply voltage	15
5.5 MPI	4	10.8 Sensor supply voltage	15
6. Outputs	4	10.9 Climatic conditions	15
6.1 Output 1	4	10.10 EMC	15
6.2 Output 2	4	10.11 Device safety	15
6.3 Active outputs	4	10.12 Mechanical data	15
7. Programming	4	10.13 Connections	15
7.1 Entering the programming	4	11. Scope of delivery	15
7.2 Choice of main menus	4	12. Ordering codes	16
7.3 Entering a sub-menu	4	13. Frequencies (typical)	16
7.4 Selecting the menu items	5	13.1 Pulse counter	16
7.5 Setting the menu items	5	13.2 Frequency meter	16
7.6 Accepting the setting	5	14. Input modes: Pulse counting	17
7.7 Ending the programming	5	15. Input modes: Timing	18
7.8 Programming menu	5	16. Input modes: Frequency meter	20
7.8.1 Default parameters	5	17. Output operations	21
7.8.2 Parameter sets	5	18. Dimensional drawings	22
7.8.3 Setting the Basic function	6		
7.8.4 Pulse counter	6		
7.8.5 Tacho/frequency meter	8		
7.8.6 Timer	9		
7.9 Setting the presets	12		
7.9.1 Setting via decade keys	13		
7.9.2 Setting with Teach-In function	13		
7.9.3 Setting the tracking presets	13		
7.10 Set function	13		

1. Preface

Please read this instruction manual carefully before installation and start-up. Please observe all warnings and advice, both for your own safety and for general plant safety. If the device is not used in accordance with this instruction manual, then the intended protection can be impaired.

2. Safety instructions and warnings

Please use the device only if its technical condition is perfect. It should be used only for its intended purpose. Please bear in mind safety aspects and potential dangers and adhere to the operating instructions at all times.

2.1 Use according to the intended purpose

The preset counter detects and measures pulses, times and frequencies up to max. 60 kHz and offers a wide variety of different operating modes. At the same time, the preset counter processes programmed presets. Use for any purpose over and beyond this will be deemed as not in accordance with its intended purpose and thus not complying with the requirements.

The application area for this device lies in industrial processes and controls, in the fields of manufacturing lines for the metal, wood, plastics, paper, glass, textile and other like industries. Over-voltages at the terminals of the device must be kept within the limits of overvoltage Category II.

The device must only be operated when mounted in a panel in the correct way and in accordance with the section *Technical Data*.

Correct operation of the device requires the mandatory use of the appropriate external safety fuse. Advice concerning the recommended fuse-protection can be found under *Technical Data*.

The device is not suitable for use in hazardous areas and for areas excluded in EN 61010 Part 1.

If the device is used to monitor machines or processes in which, in the event of a failure of the device or an error made by the operator, there might be the risk of damaging the machine or causing an accident to the operators, then it is your responsibility to take the appropriate safety measures.

2.2 Mounting in a control panel

CAUTION!

MOUNT THE DEVICE AWAY FROM HEAT SOURCES AND AVOID DIRECT CONTACT WITH CORROSIVE LIQUIDS, HOT STEAM OR SIMILAR.

Mounting instructions

1. Remove mounting clip from the device.
2. Insert the device from the front into the panel cut-out, ensuring the front-panel gasket is correctly seated.
3. Slide the fixing clip from the rear onto the housing, until the spring clamps are under tension and the upper and lower latching lugs have snapped into place.

2.3 Electrical installation

DANGER!

THE DEVICE MUST BE DISCONNECTED FROM THE POWER SUPPLY, BEFORE ANY INSTALLATION OR MAINTENANCE WORK IS CARRIED OUT. AC-POWERED DEVICES MUST ONLY BE CONNECTED TO THE LOW-VOLTAGE NETWORK VIA A SWITCH OR CIRCUIT BREAKER. INSTALLATION OR MAINTENANCE WORK MUST ONLY BE CARRIED OUT BY QUALIFIED PERSONNEL.

Advice on noise immunity

All connections are protected against external sources of interference. The installation location should be chosen so that inductive or capacitive interference does not affect the device or its connecting lines! Interference (e.g. from switch-mode power supplies, motors, clocked controllers or contactors) can be reduced by means of appropriate cable routing and wiring.

Measures to be taken:

- Use only shielded cable for signal and control lines. Connect cable shield at both ends
- The conductor cross-section of the cables should be a minimum of 0.4 mm²
- The shield connection to the equipotential bonding should be as short as possible and with a contact area as large as possible (low-impedance)
- Only connect the shields to the control panel, if the latter is also earthed
- Install the device as far away as possible from noise-containing cables
- Avoid routing signal or control cables parallel to power lines.
- Cables and their insulation should be in accordance with the intended temperature and voltage ranges

3. Description

- Six-digit multifunction LCD display
- Easy-to-read two-line LCD-display with annunciators for both the displayed preset and the status of the two outputs
- Simultaneous display of the actual value and of the presets or auxiliary counters
- Add./Sub. preset counter with two presets
- Relay outputs
- Easy-to-program
- Simple preset entry via the front keys or via the Teach-In function
- Step or tracking preset
- Pulse, frequency, time or batch counter
- Preset counter, Batch counter or Total counter (cumulative count)
- Set function for pulse and time counter
- Multiplication and division factor (00.0001–99.9999) for pulse counter and frequency meter
- Averaging and start delay for frequency meter
- Input modes:
 - Pulse counter: cnt.dir, up.dn, up.up, quad, quad2, quad4, A/B, (A-B)/Ax100%
 - Frequency meter: A, A – B, A + B, quad, A/B, (A-B)/Ax100%
 - Timer: FrErun, Auto, InpA.InpB, InpB.InpB
 - Output operations: Add, Sub, AddAr, SubAr, AddBat, SubBat, AddTot, SubTot, Trail, TrailAr
- Four-stage RESET-Mode
- Three-stage keypad locking (Lock)
- MPI input for Display Latch, Teach-In function or Set function
- Supply voltage 90–260 Vac or 10–30 Vdc

4. Display/Operating elements

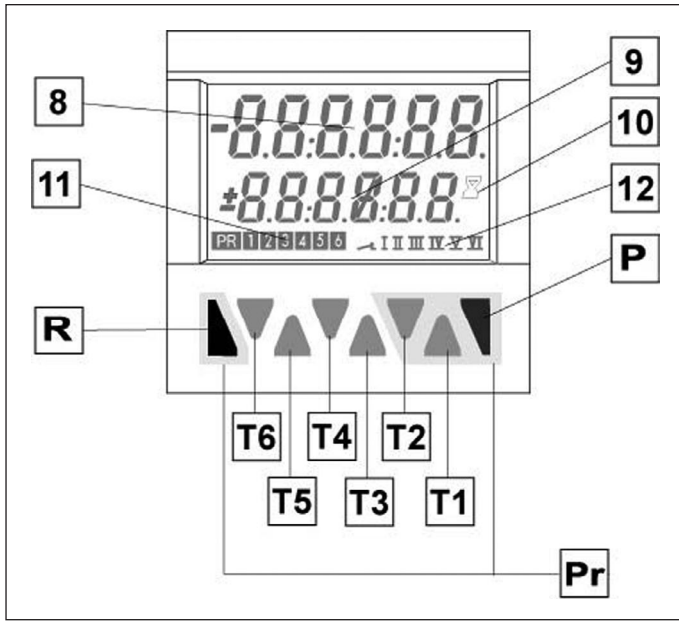

Key	Function
T1-6	Decade key T1–T6
P	Prog/Mode key
R	Reset key
8	Current count value/main counter
9	Preset value/Total count/Batch counter
10	Run display for timer
11	Shows which preset value is being displayed
12	Shows which preset output is active
Pr	Keys necessary for programming the parameters (highlighted in grey)

5. Inputs

5.1 INP A, INP B

- Signal inputs: function acc. to operating mode
- Max. frequency 60 kHz, can be damped in the programming menu to 30 Hz
- Pulse counter: count inputs
- Frequency meter: frequency inputs
- Timer: start input or start/stop inputs

5.2 Reset

- Dynamic reset input: resets the pulse counter or timer to zero (adding mode) or to preset value 2 (subtracting mode). The reset input can be inhibited in the programming menu
- Pulse counter: RESET input
- Frequency meter: no function
- Timer: RESET input

5.3 Gate

- Static gate input: function depending on operating mode
- Pulse counter: no counting while active
- Frequency meter: no counting while active
- Timer: no time measurement while active (Gate.hi); no time measurement while not active (Gate.Lo)

5.4 Lock Input

- Static keypad lock input for presets or programming. Lock-out level can be set in the programming menu

5.5 MPI

- Input. Programmable as Display Latch, Set or Teach-In input

6. Outputs

6.1 Output 1

Relay with potential-free make (NO) contact

6.2 Output 2

Relay with potential-free make (NO) contact

6.3 Active Outputs

An active output will be shown on the display as \curvearrowright I or \curvearrowright II.

For safety switching the relay outputs can be inverted, i.e. the relay will be deenergized when the presets are reached. To do this, the parameters Pr.OUT1 and Pr.OUT2 must be set to $\overline{\text{I}}$ (for permanent signal) or $\overline{\text{I}}$ or $\overline{\text{II}}$ (for timed signal).

7. Programming

7.1 Entering the program

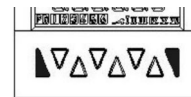

Press the Reset key and Prog/Mode key simultaneously for 3s

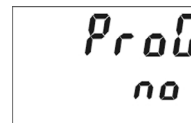

The security prompt appears in the display

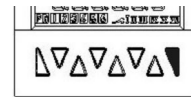

Programming can be exited again using the Prog/Mode key



Press key T2 to continue with the programming

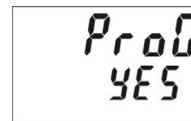

The security prompt appears in the display



Enter the main menu by pressing the Prog/Mode key

7.2 Choice of main menus



The menus are selected using the keys T2 (next) and T1 (back)

7.3 Entering a sub-menu



The sub-menu is opened with the Prog/Mode key and the first menu item is displayed

7.4 Selecting the menu items



The Prog/Mode key is used to select a menu item within the sub-menu

7.5 Setting the menu items

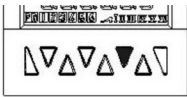

The T2 key is used to select the individual settings for the menu items



When setting count values, each decade has a key assigned to it. Each time the key is pressed, the value increments by one

7.6 Accepting the setting

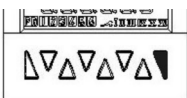

Pressing the Prog/Mode key causes the current setting to be accepted. Programming then switches to the next menu item

7.7 Ending the programming

During programming, it is possible to exit the programming at each menu item by pressing the reset key.



Press the Reset key

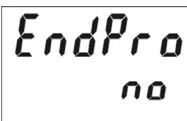

The security prompt appears in the display



Pressing the Prog/Mode key acknowledges this prompt and causes the programming menu to start again from the beginning. The previously programmed values are preserved. These can now be changed or checked again



Pressing the decade key T2 selects the termination of the programming

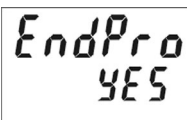

The security prompt appears in the display

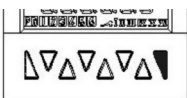

Pressing the Prog/Mode key acknowledges this prompt and terminates the programming; the modified settings are saved in the EEPROM.



The text SAVE is displayed for 2s

7.8 Programming menu

7.8.1 Default parameters

Three default parameter sets have been permanently stored; these can be adapted as required. With each acknowledgment of the parameter sets, all parameters will be reset to the values listed in the table.

The dEFAuL PUSEr can be freely programmed.

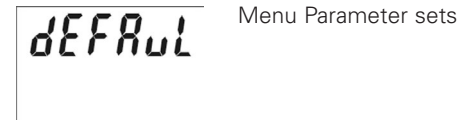

Menu Parameter sets



Default setting
Parameter set 1



Default setting
Parameter set 2



Default setting
Parameter set 3



Freely programmable
user settings

7.8.2 Parameter sets

Factory setting are highlighted in grey.

Display	PSEt 1	PSEt 2	PSEt 3
Func	Count	Count	Count
InP.PoL	PnP	PnP	PnP
FILtEr	on	oFF	oFF
Count	Cnt.dir	uP.dn	Quad
MPi	LAth	LAth	Set
Loc.InP	ProG	ProG	ProG
ModE	Add	Sub	TrAiL
FActor	01.0000	01.0000	01.0000
diViSo	01.0000	01.0000	01.0000
dP	0	0	0.00
SEtPt	000000	000000	0000.00
rESmd	Man.EL	Man.EL	Man.EL
PrES 1	on	on	on
Pr.Out 1			
t.Out	—	00.10	—
Pr.Out 2			
t.Out 2	—	00.10	00.10

7.8.3 Setting the Basic Function

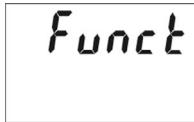

Basic function menu



Programming menu
Pulse counter (7.8.4)

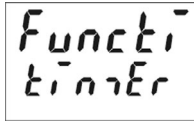

Programming menu
Timer/Hour meter (7.8.6)



Programming menu
Tacho/Frequency meter (7.8.5)

7.8.4 Pulse Counter

7.8.4.1 Main menu for Signal and Control inputs

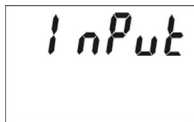

Main menu for programming the
signal and control inputs

Input polarity

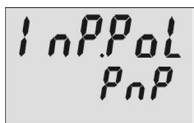

PNP: switching to Plus
for all inputs in common

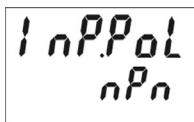

NPN: switching to 0V
for all inputs in common

Filter for signal inputs InpA and InpB



Maximum count frequency



Damped to approx. 30 Hz
(for control with mechanical contacts)

Count Input mode

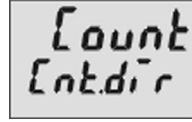

Count/Direction

INP A: count input
INP B: count direction input



Differential counting [A – B]

INP A: count input add
INP B: count input sub



Totalizing [A + B]

INP A: count input add
INP B: count input add



Quadrature input

INP A: count input 0°
INP B: count input 90°



Quadrature with pulse doubling

INP A: count input 0°
INP B: count input 90°
Each pulse edge of INP A will be counted



Quadrature x4

INP A: count input 0°
INP B: count input 90°
Each pulse edge of INP A
and INP B will be counted.



Ratio measurement [A/B]

Inp A: count input A
Inp B: count input B



Percentage differential counting
[(A – B)/A in %]

Inp A: count input A
Inp B: count input B

User input



When the MPI input is activated, the display
is “frozen” and remains “frozen” until the
MPI input is deactivated. Internally the
preset counter continues counting

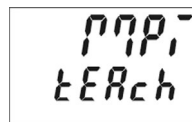

When the MPI input is activated, the
current count value for the preset
that has just been selected will be adopted
as the new preset value. See also 7.9

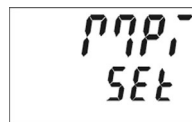

When the MPI input is activated, the
preset counter will be set to the value
specified in the parameter SEtPt.
See also 7.10

Lock input

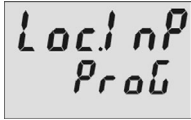

When the Lock input is activated, the programming is inhibited



When the Lock input is activated, the setting of the preset values is inhibited



When the Lock input is activated, the setting of the preset values and the programming are both inhibited

7.8.4.2 Main menu for Output operations

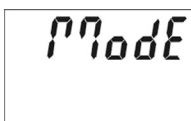

Main menu for determining the operation of the outputs



Count mode ADD

Outputs active when count status \geq preset value
 Reset to zero

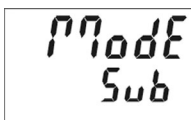

Count mode SUBTRACT

Output 1 active when count status \leq preset value 1
 Output 2 active when count status ≤ 0
 Reset to preset 2



Count mode ADDING with automatic reset

Output 1 active when count status \geq preset value 1
 Output 2 (timed signal) active when count status = preset value 2
 Automatic reset to zero when count status = preset value 2
 Reset to zero

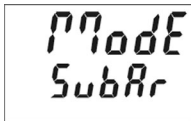

Count mode SUBTRACTING with automatic reset

Output 1 active when count status \leq preset value 1
 Output 2 (timed signal) active when count status = 0
 Automatic reset to preset 2 when count status = 0
 Reset to preset 2



Count mode ADDING with automatic reset and Batch counter

Output 2 (timed signal) active when main counter = preset value 2
 Automatic reset to zero when main counter = preset 2
 Batch counter counts the number of automatic repetitions of preset 2
 Output 1 active when Batch counter \geq preset 1
 Manual reset sets both counters to zero.
 Electrical reset only sets the main counter to zero



Count mode SUBTRACTING with automatic reset and Batch counter

Output 2 (timed signal) active when main counter = zero
 Automatic reset to preset 2 when main counter = zero
 Batch counter counts the number of automatic repetitions of preset 2
 Output 1 active when Batch counter \geq preset 1
 Manual reset sets main counter to preset value 2, batch counter to zero
 Electrical reset only sets the main counter to preset value 2



Count mode ADDING with automatic reset and Total counter

Output 2 (timed signal) active when main counter = preset value 2
 Automatic reset to zero when main counter = preset value 2
 Total counter counts all the count pulses from the main counter
 Output 1 active when total counter \geq preset value 1
 Manual Reset sets both counters to zero
 Electrical reset only sets the main counter to zero



Count mode SUBTRACTING with automatic reset and Total counter

Output 2 (timed signal) active when main counter = zero
 Automatic reset to preset value 2 when main counter = zero
 Total counter counts (sub from preset value 1) all count pulses from main counter
 Output 1 active when Total counter \leq zero
 Manual reset sets both counters to the preset values
 Electrical reset sets only main counter to preset value 2



Tracking Preset mode

When preset 2 is changed then preset 1 automatically tracks it.
 Reset to zero
 Preset 1 relative to preset 2 (see also section 17, Output operations)

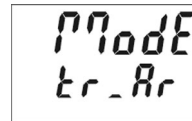

Tracking Preset mode with automatic reset

When preset 2 is changed then preset 1 automatically tracks it. Reset to zero.
 Automatic reset to zero when main counter = preset value 2.
 Preset 1 relative to Preset 2 (see also section 17, Output operations)

For the subtracting modes (SUB, SUBAR, SUBBAT and SUBTOT), a "Reset" (via the key or input) resets the counter/the time counter to a new preset value 2.

7.8.4.3 Main menu for configuration

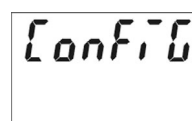

Main menu for matching the input pulses and display

Multiplication factor



Multiplication factor can be programmed from 00.0001 to 99.9999.
 The setting 00.0000 will not be accepted

Division factor



Division factor can be programmed from 01.0000 to 99.9999. The setting <01.0000 will not be accepted

Decimal point setting

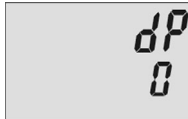

Decimal point (only optical function)
0 no decimal place
0.0 1 decimal place
0.00 2 decimal places
0.000 3 decimal places
0.0000 4 decimal places
0.00000 5 decimal places

Set value



Set value can be programmed from -999999 to 999999. A previously programmed decimal point will be displayed

7.8.4.4 Main menu for reset mode

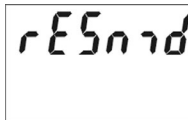

Setting the reset mode

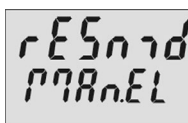

Manual reset (with red key) and electrical reset (reset input)

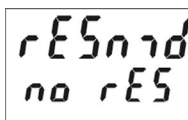

No reset possible (red key and reset input inhibited)

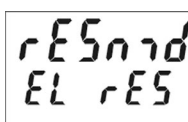

Only electrical reset possible (reset input)

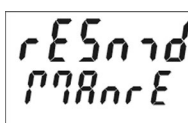

Only manual reset possible (red key)

7.8.4.5 Preset 1

See below 7.8.6.5

7.8.4.6 Preset 2

See below 7.8.6.8

7.8.5 Tacho/frequency meter

7.8.5.1 Main menu for Signal and Control inputs

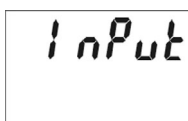

Main menu for programming the signal and control inputs

Input polarity

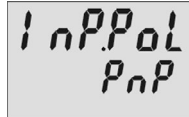

PNP: switching to Plus for all inputs in common

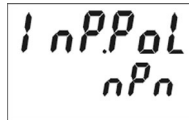

NPN: switching to 0V for all inputs in common

Filter for signal inputs Inp A and Inp B



Maximum count frequency



Damped to approx. 30 Hz (for control with mechanical contacts)

Input mode frequency measurement

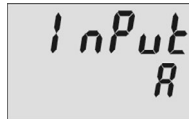

Simple frequency measurement

Inp A: Frequency input
Inp B: No function

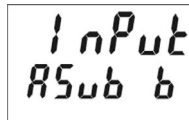

Differential measurement [A - B]

Inp A: Frequency input A
Inp B: Frequency input B

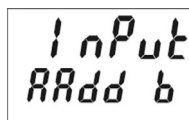

Total measurement [A + B]

Inp A: Frequency input A
Inp B: Frequency input B

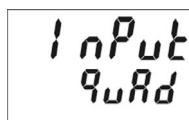

Frequency measurement with direction recognition [Quad]

Inp A: Frequency input 0°
Inp B: Frequency input 90°

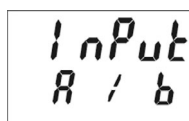

Ratio measurement [A/B]

Inp A: Frequency input A
Inp B: Frequency input B

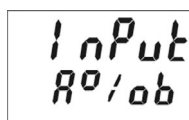

Percentage differential measurement [(A-B)/A in %]

Inp A: Frequency input A
Inp B: Frequency input B

User input



When the MPI input is activated, the display is "frozen" and remains "frozen" until the MPI input is deactivated. Internally the frequency meter continues running

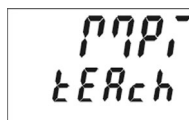

When the MPI input is activated, the current frequency for the preset that has just been selected will be adopted as the new preset value. See also 7.9

Lock input

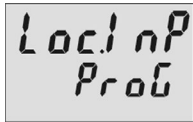

When the Lock input is activated, the programming is inhibited



When the Lock input is activated the setting of the preset values is inhibited

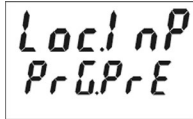

When the Lock input is activated the setting of the preset values and the programming are both inhibited

7.8.5.2 Main menu for configuration

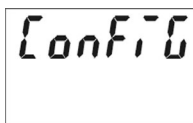

Main menu for matching the input pulses and display

Multiplication factor

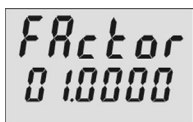

Multiplication factor can be programmed from 00.0001 to 99.9999.
 The setting 00.0000 will not be accepted

Division factor

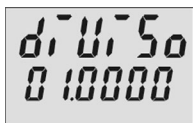

Division factor can be programmed from 01.0000 to 99.9999.
 The setting <01.0000 will not be accepted

Display mode



Calculation and display of the frequency/speed in 1/s



Calculation and display of the frequency/speed in 1/min

Decimal point setting

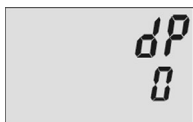

Decimal point (determines the resolution)
 0 no decimal place
 0.0 1 decimal place
 0.00 2 decimal places
 0.000 3 decimal places

Moving average

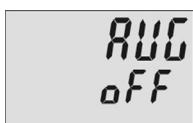

Moving average calculated
 AVG 2: over 2 measurements
 AVG 5: over 5 measurements
 AVG 10: over 10 measurements
 AVG 20: over 20 measurements

Start delay

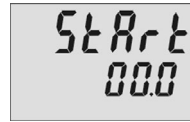

Programmable from 00.0 to 99.9s
 At the start of a measurement the measurement results within this time-period are ignored

Waiting time

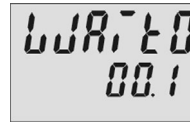

Programmable from 00.1 to 99.9s.
 This value specifies how much time should elapse, after the last valid edge, before zero is to be displayed

7.8.5.3 Preset 1

See below 7.8.6.5

7.8.5.4 Preset 2

See below 7.8.6.6

7.8.6 Timer

7.8.6.1 Main menu for Signal and Control inputs

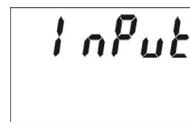

Main menu for programming the signal and control inputs

Input polarity

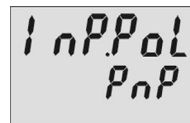

PNP: switching to Plus for all inputs in common

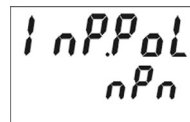

nPn: switching to 0V for all inputs in common

Filter for the signal inputs Inp A and Inp B

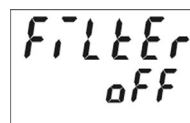

For electronic control of the signal inputs



For mechanical control of the signal inputs (for control with mechanical contacts)

Input mode time measurement

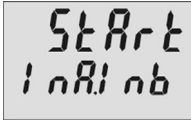

Start: Edge to Inp A
Stop: Edge to Inp B



Start: 1. Edge to Inp B
Stop: 2. Edge to Inp B

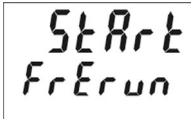

Timing can only be controlled via the Gate input
Inp A and Inp B: no function



The timer is reset by means of a RESET (to zero when adding, to preset 2 when subtracting) and then starts timing again.

Timing is stopped with adding operations when preset 2 is reached.

Timing is stopped with subtracting operations when zero is reached.

A RESET during the timing process also causes this to stop.

Inp A and Inp B: no function

Gate control for timing



Timing takes place when the Gate input is not active



Timing takes place when the Gate input is active

User input



When the MPI input is activated, the display is "frozen" and remains "frozen" until the MPI input is deactivated. Internally the preset timer continues counting



When the MPI input is activated, the current count value for the preset that has just been selected will be adopted as the new preset value. See also 7.9



When the MPI input is activated, the preset timer will be set to the value specified in the parameter SEtPt. See also 7.10

Lock input

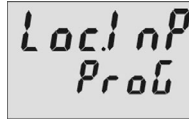

When the Lock input is activated, the programming is inhibited

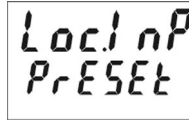

When the Lock input is activated, the setting of the preset values is inhibited



When the Lock input is activated, the setting of the preset values and the programming are both inhibited

7.8.6.2 Main menu for output operations

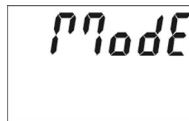

Main menu for determining the operation of the outputs



Count mode ADD

Outputs active when count status \geq preset value
Reset to zero

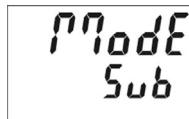

Count mode SUBTRACT

Output 1 active when count status \leq preset value 1
Output 2 active when count status ≤ 0
Reset to preset 2

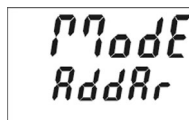

Count mode ADDING with automatic reset

Output 1 active when count status \geq preset value 1
Output 2 (timed signal) active when count status = preset value 2
Automatic reset to zero when count status = preset value 2
Reset to zero

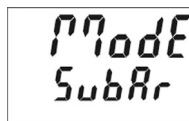

Count mode SUBTRACTING with automatic reset

Output 1 active when count status \leq preset value 1
Output 2 (timed signal) active when count status = 0
Automatic reset to preset 2 when count status = 0
Reset to preset 2

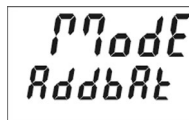

Count mode ADDING with automatic reset and Batch counter

Output 2 (timed output) active when main counter = preset value 2
Automatic reset to zero when main counter = preset value 2
Batch counter counts the number of automatic repetitions of preset 2
Output 1 active when batch counter \geq preset 1
Manual reset sets both counters to zero
electrical reset sets only main counter to zero



Count mode SUBTRACTING with automatic reset and Batch counter

Output 2 (timed signal) active when main counter = zero
 Automatic reset to preset 2 when main counter = zero
 Batch counter counts the number of automatic repetitions of preset 2
 Output 1 active when batch counter \geq preset 1
 Manual reset sets main counters to preset value 2 and batch counter to zero
 Electronic reset only sets the main counter to preset value 2



Count mode ADDING with automatic reset and Total counter

Output 2 (timed signal) active when main counter = preset value 2
 Automatic reset to zero when main counter = preset value 2
 Total counter counts all the count pulses from the main counter
 Output 1 active when total counter \geq preset value 1
 Manual Reset sets both counters to zero
 Electronic reset only sets the main counter to zero

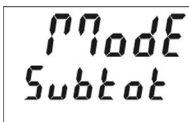

Count mode SUBTRACTING with automatic reset and Total counter

Output 2 (timed signal) active when main counter = zero
 Automatic reset to preset value 2 when main counter = zero
 Total counter counts (sub from preset value 1) all count pulses from main counter
 Output 1 active when Total counter $<$ zero
 Manual reset sets both counters to the preset values
 Electronic reset sets only main counter to preset value 2

Tracking preset mode

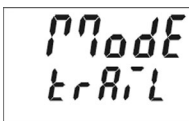

When preset 2 is changed then preset 1 automatically tracks it.
 Reset to zero
 Preset 1 relative to preset 2 (see also section 17, Output operations)

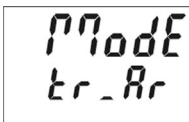

Tracking Preset mode with automatic reset

When preset 2 is changed then preset 1 automatically tracks it.
 Reset to zero.
 Automatic reset to zero when main counter = preset value 2.
 Preset 1 relative to Preset 2 (see also section 17, Output operations)

For the subtracting modes (SUB, SUBAR, SUBBAT and SUBTOT), a "Reset" (via the key or input) resets the counter/the time counter to a new preset value 2.

7.8.6.3 Main menu for configuration



Main menu for matching the time ranges and display

Unit of time

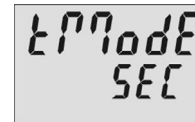

Unit of time: seconds
 Decimal point setting determines the resolution

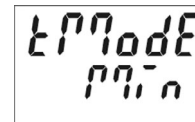

Unit of time: minutes
 Decimal point setting determines the resolution

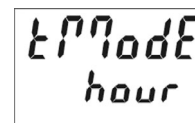

Unit of time: hours
 Decimal point setting determines the resolution

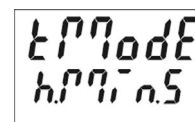

Unit of time: hrs. min. sec.

Decimal point setting (Resolution)



Decimal place (determines the resolution)
 0 no decimal place
 0.0 1 decimal place
 0.00 2 decimal places
 0.000 3 decimal places

Set value



Set value can be programmed from 000000 to 999999
 A previously programmed decimal point will be displayed

7.8.6.4 Main menu for reset mode

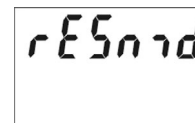

Setting the reset mode

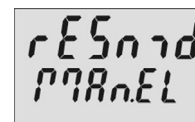

Manual reset (with red key) and electrical reset (reset input)

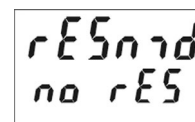

No reset possible (red key and reset input inhibited)

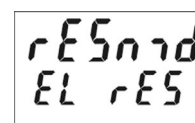



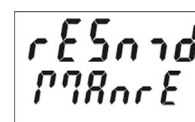

Only electrical reset possible (reset input)



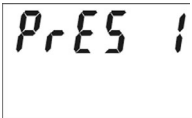
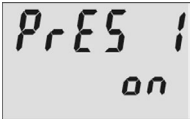
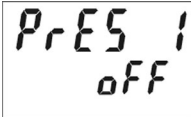
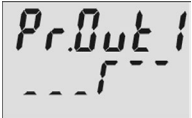
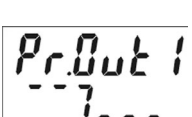
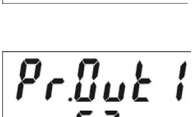

Only manual reset possible (red key)

7.8.6.5 Main menu for preset 1

	Main menu for turning preset 1 ON/OFF
	Preset 1 ON
	Preset 1 OFF and no function
	ADD mode output operations: permanent signal at output 1, becomes active when count ≥ preset 1 SUB mode output operations: permanent signal at output 1, becomes active when count ≤ preset 1
	ADD mode output operations: permanent signal at output 1, becomes passive when count ≥ preset 1 SUB mode output operations: permanent signal at output 1, becomes passive when count ≤ preset 1
	ADD mode output operations: timed signal at output 1, becomes active when count ≥ preset 1. (Activation only in positive direction) SUB mode output operations: timed output at output 1, becomes active when count ≤ preset 1 (Activation only in negative direction)
	ADD mode output operations: timed signal at output 1, becomes passive when count ≥ preset 1. (Deactivation only in positive direction) SUB mode output operations: timed output at output 1, becomes passive when count ≤ preset 1. (Deactivation only in negative direction)
	ADD mode output operations: timed signal at output 1, becomes active with positive direction and when count ≥ preset 1 and subsequently active with negative direction and when count ≤ preset 1 SUB mode output operations: timed signal at output 1, becomes active with negative direction and when count ≤ preset 1 and subsequently active with positive direction and when count ≥ preset 1
	ADD mode output operations: timed signal at output 1, becomes passive with positive direction and when count ≥ preset 1 and subsequently passive with negative direction and when count ≤ preset 1 SUB mode output operations: timed output at output 1, becomes passive with negative direction and when count ≤ preset 1 and subsequently passive with positive direction and when count ≥ preset 1
	Duration of timed signal of output 1, programmable from 00.01 to 99.99s. Timed signal is post-triggered

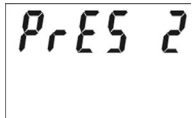
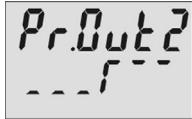
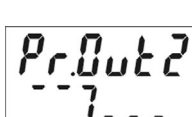
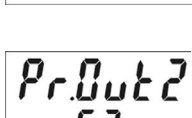
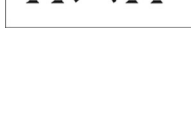
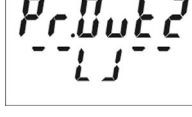
7.8.6.6 Main menu for preset 2

	Main menu for preset 2
	ADD mode output operations: permanent signal at output 2, becomes active when count ≥ preset 2 SUB mode output operations: permanent signal at output 2, becomes active when count ≤ zero
	ADD mode output operations: permanent signal at output 2, becomes passive when count ≥ preset 2 SUB mode output operations: permanent signal at output 2, becomes passive when count ≤ zero
	ADD mode output operations: timed signal at output 2, becomes active when count ≥ preset 2 (Activation only in positive direction). SUB mode output operations: permanent signal at output 2, becomes active when count ≤ zero (Activation only in negative direction)
	ADD mode output operations: timed signal at output 2, becomes passive when count ≥ preset 2 (Deactivation only in positive direction) SUB mode output operations: permanent signal at output 2, becomes passive when count ≤ zero (Deactivation only in negative direction)
	ADD mode output operations: timed signal at output 2, becomes active with positive direction and when count ≥ preset 2 and subsequently with negative direction and when count ≤ preset 2 SUB mode output operations: timed signal at output 2, becomes active with negative direction and when count ≤ zero and subsequently with positive direction and when count ≥ zero
	ADD mode output operations: timed signal at output 2, becomes passive with positive direction and when count ≥ preset 2 and subsequently with negative direction and when count ≤ preset 2 SUB mode output operations: timed signal at output 2, becomes passive with negative direction and when count ≤ zero and subsequently with positive direction and when count ≥ zero
	Duration of timed signal of output 2, programmable from 00.01 to 99.99s. Timed output is post-triggered

Active:
Relay is activated when the preset value is reached.

Passive:
Relay becomes de-energized when the preset value is reached.

7.9 Setting the presets

7.9.1 Setting via decade keys

In programming mode preset 2 will always be displayed in the lower line. This is except for the output operations AddBat, SubBat, AddTot and SubTot.

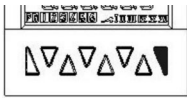

Press the Prog/Mode key until the preset to be changed is displayed—**PR1** or **PR2**

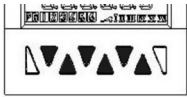

Press any decade key

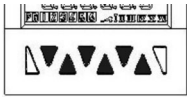

Display switches to the editor mode



Press the Prog/Mode key to confirm the value and save it

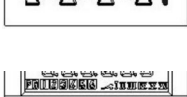

Display switches to the editor mode of the next preset **PR2** or **PR1**

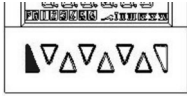

Approx. 3s after the last press of the decade keys, or by pressing the Reset key, the new preset value will be accepted and the counter will switch back to operating mode

7.9.2 Setting with Teach-In function



Program the MPI input to *tEAch*

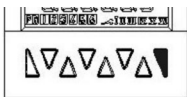

In programming mode, select the preset to be changed using the Prog/Mode key

Briefly activate the MPI (NPN or PNP input logic)

- The current count value will be adopted as the new preset value
- The preset value can subsequently be further modified via the decade keypad

7.9.3 Setting the tracking presets (trail)

If a tracking preset has been programmed, the value for preset 2 can be set either via the decade keypad or via the Teach-In function.

However the value for preset 1 must be entered via the decade keypad. In this instance, it is not possible to use the Teach-In function.

7.10 Set function

Both the pulse counter and the timer can be set to a default value by means of the Set function.

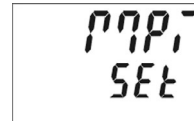

Program the MPI input to SEt

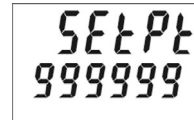

Set menu item SEtPt to the desired value

Briefly activate the MPI (NPN or PNP input logic)

- In Adding modes: the pulse counter or timer will be set to the SEtPt value
- In Subtracting modes: the pulse counter or timer will be set to a value that is the sum of Preset 2 value and the value of SEtPt

8. Error message

Message	Description
Err 1	Set value is outside the permitted range

9. Connections

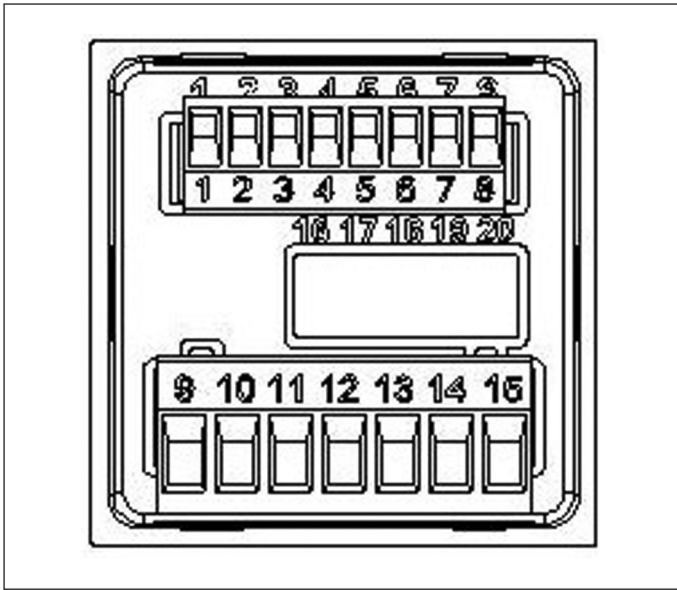

Figure 1. Connections

9.1 Signal and control inputs

Number	Designation	Function
1	AC: 24 Vdc/80 mA DC: UB connected through	Sensor supply voltage
2	GND (0 Vdc)	Common connection signal and control inputs
3	INP A	Signal input A
4	INP B	Signal input B
5	RESET	Reset input
6	LOCK	Keypad lock
7	GATE	Gate input
8	MPI	User input

9.2 Supply voltage and outputs

Number	Designation	Function
9	Relay contact C.1	Output 1
10	Relay contact N.O.1	
11	Relay contact C.2	Output 2
12	Relay contact N.O.2	
13	Relay contact N.C.2	
14	AC: 90–260 Vac N~ DC: 10–30 Vdc	Supply voltage
15	AC: 90–260 Vac L~ DC: GND (0 Vdc)	Supply voltage

10. Technical data

10.1 General data

- Display: LCD positive or negative, backlit 2 x 6-digit
- Digit height
 - Upper line: 9 mm
 - Lower line: 7 mm
 - Special characters: 2 mm
- Overload: Blinking, 1s
- Underload: Counter loses up to 1 decade, no pulses
- Data retention: >10 years, EEPROM
- Operation: 8 keys

10.2 Pulse counter

- Count frequency: max. 55 kHz (see section 13, Frequencies)
- Response time of the outputs—Relays
 - Add/Sub/Trial: <13 ms
 - With automatic repeat: <13 ms
 - A/B; (A-B)/A: <34 ms

10.3 Tacho/frequency meter

- Frequency range: 0.01 Hz to 65 kHz (see section 13, Frequencies)
- Measuring principle
 - ≤76.3 Hz Time interval (period measurement)
 - >76.3 Hz Gate time
 - Gate time approx. 13.1 ms
- Measuring error: <0.1% per channel
- Response time of the outputs
 - 1-channel operation: <100 ms at 40 kHz, <350 ms at 65 kHz
 - 2-channel operation: <150 ms at 40 kHz, <600 ms at 65 kHz

10.4 Timer

- Seconds: 0.001s–999 999s
- Minutes: 0.001min–999 999min
- Hours: 0.001h–999 999h
- h.min.s: 00h.00min.01s–99h.59min.59s
- Min. time measurable: 500 μs
- Measuring error: <50 ppm
- Response time of the outputs
 - Relays: <13 ms

10.5 Signal and control inputs

- Polarity: programmable NPN/PNP for all inputs in common
- Input resistance: 5 kohms
- Pulse shape: any
- Switching level with AC supply:
 - HTL level: Low: 0–4 Vdc, High: 12–30 Vdc
 - 5V level: Low: 0–2 Vdc, High: 3.5–30 Vdc
- Switching level with DC supply:
 - HTL level: Low: 0–0.2 x UB, High: 0.6 x UB–30 Vdc
 - 5V level: Low: 0–2 Vdc, High: 3.5–30 Vdc
- Minimum pulse length of the Reset input: 1 ms
- Minimum pulse length of the Control inputs: 10 ms

10.6 Outputs

Output 1

- Relay with make contact programmable as NC or NO
- Switching voltage: max. 250 Vac/110 Vdc
- Switching current: max. 3A AC/Vdc, min. 30 mA DC
- Switching capacity: max. 750 VA/90W
- Mechanical service life (switching cycles): 2 x 10⁷
- Number of switching cycles at 3A/250 Vac: 1 x 10⁵
- Number of switching cycles at 3A/30 Vdc: 1 x 10⁵

Output 2

- Relay with changeover contact
- Switching voltage: max. 250 Vac/150 Vdc
- Switching current: max. 3A AC/A DC, min. 30 mA DC
- Switching capacity: max. 750 VA/90W
- Mechanical service life (switching cycles): 20 x 10⁵
- Number of switching cycles at 3A/250 Vac: 5 x 10⁴
- Number of switching cycles at 3A/30 Vdc: 5 x 10⁴

10.7 Supply voltage

- AC supply:
 - 90–260 Vac/max. 8 VA 50/60 Hz
 - Ext. fuse protection: T 0.1A
- DC supply:
 - 10–30 Vdc/ max. 1.5W reverse polarity protection
 - Ext. fuse protection T 0.2A

10.8 Sensor supply voltage

- AC supply: 24 Vdc ±15%, 80 mA
- DC supply: max. 80 mA, external voltage supply is connected through

10.9 Climatic conditions

- Operating temperature: –20°C to 65°C
- Storage temperature: –25°C to 75°C
- Relative humidity: RH. 93% at 40°C, non-condensing
- Altitude: to 2000m

10.10 EMC

- Noise immunity: EN61000-6-2 with shielded signal and control cables
- Noise emission: EN55011 Class B

10.11 Device safety

- Design to: EN61010 Part 1
- Protection class: Class 2
- Application area: Soiling Level 2

10.12 Mechanical data

- Housing: Panel-mount housing to DIN 43 700, RAL 7021
- Dimensions: 48 x 48 x 91 mm
- Panel cut-out: 45+0.6 x 45+0.6 mm
- Installation depth: ca. 107 mm incl. terminals
- Weight: ca. 125g
- Protection: IP 65 (front)
- Housing material: Polycarbonate UL94 V-2
- Vibration resistance: 10–55 Hz/1 mm/XYZ (EN60068-2-6): 30 min in each direction
- Shock resistance: 100G/XYZ (EN60068-2-27): 3 times in each direction (EN60068-2-29): 10G/6 ms/XYZ 2000 times in each direction
- Cleaning: The front of the unit should only be cleaned using a soft damp (water) cloth

10.13 Connections

- Supply voltage and outputs:
 - Plug-in screw terminal: 7-pin, RM 5.08
 - Core cross section: max. 2.5 mm²
- Signal and control inputs:
 - Plug-in screw terminal: 8-pin, RM 3.81
 - Core cross-section: max. 1.5 mm²

11. Scope of delivery

- Preset counter
- Mounting clip
- Instruction manual

12. Ordering codes

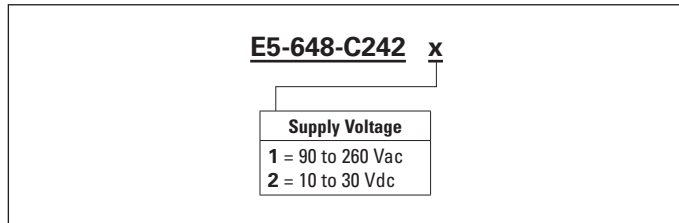

13. Frequencies (typical)

13.1 Pulse counter

HTL level

- AC supply
 - Typ. Low: 2.5V
 - Typ. High: 22V
- DC supply—12V
 - Typ. Low: 2V
 - Typ. High: 10V
- DC supply—24V
 - Typ. Low: 2.5V
 - Typ. High: 22V

Display	Add Sub Trail	AddAr SubAr AddBat SubBat TrailAr	AddTot SubTot
Cnt.Dir	55 kHz	2.8 kHz	2.7 kHz
Up.Dn Up.Up	29 kHz	2.8 kHz	2.7 kHz
Quad Quad 2	28 kHz	1.4 kHz	1.3 kHz
Quad 4	18 kHz	1.2 kHz	0.9 kHz
A/B (A-B)/A	29 kHz	29 kHz	29 kHz

5V level

- Typ. Low: 1.0V
- Typ. High: 4.0V

Display	Add Sub Trail	AddAr SubAr AddBat SubBat TrailAr	AddTot SubTot
Cnt.Dir	9 kHz	2.7 kHz	2.4 kHz
Up.Dn Up.Up	9 kHz	2.7 kHz	2.4 kHz
Quad Quad 2	9 kHz	1.2 kHz	1.2 kHz
Quad 4	9 kHz	1.2 kHz	0.9 kHz
A/B (A-B)/A	9 kHz	9 kHz	9 kHz

13.2 Frequency meter

HTL level

- AC supply
 - Typ. Low: 2.5V
 - Typ. High: 22V
- DC supply—12V
 - Typ. Low: 2V
 - Typ. High: 10V
- DC supply—24V
 - Typ. Low: 2.5V
 - Typ. High: 22V

5V level

- Typ. Low: 1.0V
- Typ. High: 4.0V

Description	HTL	5V
A	65 kHz	9 kHz
A – B A + B A/B (A-B)/A	65 kHz	9 kHz
Quad	30 kHz	9 kHz

Switching levels of the input

Switching levels with AC supply:

- HTL level
 - Low: 0–4 Vdc
 - High: 12–30 Vdc
- 5V level
 - Low: 0–2 Vdc
 - High: 3.5–30 Vdc

Switching levels with DC supply:

- HTL level
 - Low: 0–0.2 x UB
 - High: 0.6 x UB–30 Vdc
- 5V level
 - Low: 0–2 Vdc
 - High: 3.5–30 Vdc

14. Input modes: Pulse counting

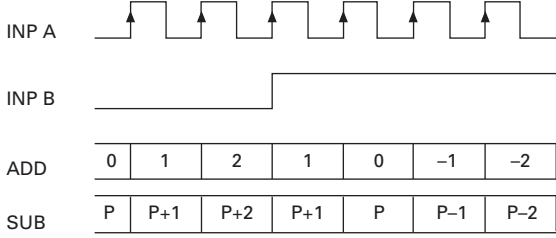
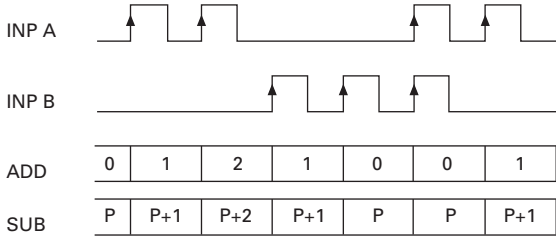
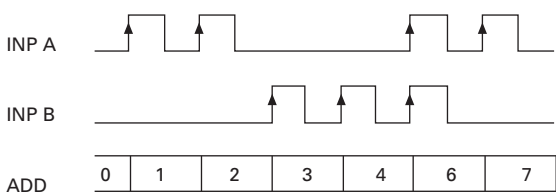
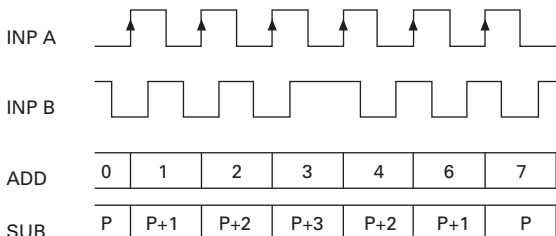
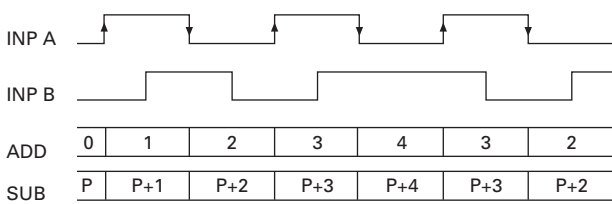
Function	Diagram ① P = Preset	PNP: Count on rising edge NPN: Count on falling edge																
Cnt.Dir	 <p>INP A</p> <p>INP B</p> <table border="1"> <tr> <td>ADD</td> <td>0</td> <td>1</td> <td>2</td> <td>1</td> <td>0</td> <td>-1</td> <td>-2</td> </tr> <tr> <td>SUB</td> <td>P</td> <td>P+1</td> <td>P+2</td> <td>P+1</td> <td>P</td> <td>P-1</td> <td>P-2</td> </tr> </table>	ADD	0	1	2	1	0	-1	-2	SUB	P	P+1	P+2	P+1	P	P-1	P-2	<p>Inp A: Count input Inp B: Count direction Add: Display 0 --> Preset Sub: Display Preset -> 0</p>
ADD	0	1	2	1	0	-1	-2											
SUB	P	P+1	P+2	P+1	P	P-1	P-2											
Up.Dn	 <p>INP A</p> <p>INP B</p> <table border="1"> <tr> <td>ADD</td> <td>0</td> <td>1</td> <td>2</td> <td>1</td> <td>0</td> <td>0</td> <td>1</td> </tr> <tr> <td>SUB</td> <td>P</td> <td>P+1</td> <td>P+2</td> <td>P+1</td> <td>P</td> <td>P</td> <td>P+1</td> </tr> </table>	ADD	0	1	2	1	0	0	1	SUB	P	P+1	P+2	P+1	P	P	P+1	<p>Inp A: Count input add Inp B: Count input sub Add: Display 0 --> Preset Sub: Display Preset -> 0</p>
ADD	0	1	2	1	0	0	1											
SUB	P	P+1	P+2	P+1	P	P	P+1											
Up.Up	 <p>INP A</p> <p>INP B</p> <table border="1"> <tr> <td>ADD</td> <td>0</td> <td>1</td> <td>2</td> <td>3</td> <td>4</td> <td>6</td> <td>7</td> </tr> <tr> <td>SUB</td> <td>P</td> <td>P+1</td> <td>P+2</td> <td>P+3</td> <td>P+2</td> <td>P+1</td> <td>P</td> </tr> </table>	ADD	0	1	2	3	4	6	7	SUB	P	P+1	P+2	P+3	P+2	P+1	P	<p>Inp A: Count input 1 add Inp B: Count input 2 add Add: Display 0 --> Preset</p>
ADD	0	1	2	3	4	6	7											
SUB	P	P+1	P+2	P+3	P+2	P+1	P											
Quad	 <p>INP A</p> <p>INP B</p> <table border="1"> <tr> <td>ADD</td> <td>0</td> <td>1</td> <td>2</td> <td>3</td> <td>4</td> <td>6</td> <td>7</td> </tr> <tr> <td>SUB</td> <td>P</td> <td>P+1</td> <td>P+2</td> <td>P+3</td> <td>P+2</td> <td>P+1</td> <td>P</td> </tr> </table>	ADD	0	1	2	3	4	6	7	SUB	P	P+1	P+2	P+3	P+2	P+1	P	<p>A 90° B Inp A: Count input Count on one edge Inp B: Reverse direction Add: Display 0 --> Preset Sub: Display Preset -> 0</p>
ADD	0	1	2	3	4	6	7											
SUB	P	P+1	P+2	P+3	P+2	P+1	P											
Quad 2	 <p>INP A</p> <p>INP B</p> <table border="1"> <tr> <td>ADD</td> <td>0</td> <td>1</td> <td>2</td> <td>3</td> <td>4</td> <td>3</td> <td>2</td> </tr> <tr> <td>SUB</td> <td>P</td> <td>P+1</td> <td>P+2</td> <td>P+3</td> <td>P+4</td> <td>P+3</td> <td>P+2</td> </tr> </table>	ADD	0	1	2	3	4	3	2	SUB	P	P+1	P+2	P+3	P+4	P+3	P+2	<p>A 90° B Inp A: Count input Count on rising and on falling edges Inp B: Reverse direction Add: Display 0 --> Preset Sub: Display Preset -> 0</p>
ADD	0	1	2	3	4	3	2											
SUB	P	P+1	P+2	P+3	P+4	P+3	P+2											

① No counting when GATE input is active

14. Input modes: Pulse counting, continued

Function	Diagram ① P = Preset	PNP: Count on rising edge NPN: Count on falling edge																								
Quad 4	<p>INP A</p> <p>INP B</p> <p>ADD</p> <table border="1"> <tr> <td>0</td><td>1</td><td>2</td><td>3</td><td>4</td><td>5</td><td>6</td><td>7</td><td>6</td><td>5</td><td>4</td><td>3</td> </tr> </table> <p>SUB</p> <table border="1"> <tr> <td>P</td><td>P+1</td><td>P+2</td><td>P+3</td><td>P+4</td><td>P+5</td><td>P+6</td><td>P+7</td><td>P+6</td><td>P+5</td><td>P+4</td><td>P+3</td> </tr> </table>	0	1	2	3	4	5	6	7	6	5	4	3	P	P+1	P+2	P+3	P+4	P+5	P+6	P+7	P+6	P+5	P+4	P+3	A 90° B Inp A: Count input Count on rising and on falling edges Inp B: Count input Count on rising and on falling edges, Reverse direction Add: Display 0 --> Preset Sub: Display Preset -> 0
0	1	2	3	4	5	6	7	6	5	4	3															
P	P+1	P+2	P+3	P+4	P+5	P+6	P+7	P+6	P+5	P+4	P+3															

A/B	<p>INP A</p> <p>Counts A</p> <table border="1"> <tr> <td>0</td><td>1</td><td>1</td><td>1</td><td>2</td><td>3</td><td>4</td> </tr> </table> <p>INP B</p> <p>Counts B</p> <table border="1"> <tr> <td>0</td><td>1</td><td>2</td><td>3</td><td>3</td><td>4</td><td>4</td> </tr> </table> <p>Display</p> <table border="1"> <tr> <td>0</td><td>1</td><td>0.5</td><td>0.33</td><td>0.66</td><td>0.75</td><td>1</td> </tr> </table>	0	1	1	1	2	3	4	0	1	2	3	3	4	4	0	1	0.5	0.33	0.66	0.75	1	Inp A: Count input 1 Inp B: Count input 2 Formula A/B
0	1	1	1	2	3	4																	
0	1	2	3	3	4	4																	
0	1	0.5	0.33	0.66	0.75	1																	

(A-B)/A	<p>INP A</p> <p>Counts A</p> <table border="1"> <tr> <td>0</td><td>1</td><td>1</td><td>1</td><td>2</td><td>3</td><td>4</td> </tr> </table> <p>INP B</p> <p>Counts B</p> <table border="1"> <tr> <td>0</td><td>1</td><td>2</td><td>3</td><td>3</td><td>4</td><td>4</td> </tr> </table> <p>Display</p> <table border="1"> <tr> <td>0%</td><td>1%</td><td>-100%</td><td>-200%</td><td>-50%</td><td>-33%</td><td>0%</td> </tr> </table>	0	1	1	1	2	3	4	0	1	2	3	3	4	4	0%	1%	-100%	-200%	-50%	-33%	0%	Inp A: Count input 1 Inp B: Count input 2 Formula: $(A - B)/A \times 100$
0	1	1	1	2	3	4																	
0	1	2	3	3	4	4																	
0%	1%	-100%	-200%	-50%	-33%	0%																	

① No counting when GATE input is active

15. Input modes: Timing

Function	Diagram	PNP: Count on rising edge NPN: Count on falling edge
InA.InB	<p>INP A: [Pulse] [Pulse]</p> <p>INP B: [Pulse] [Pulse]</p> <p>GATE: [on] [off]</p> <p>ADD: 0 T2</p> <p>SUB: P P-T2</p>	<p>Inp A: Start Inp B: Stop Add: Display 0 --> Preset Sub: Display Preset -> 0</p>
InB.InB	<p>INP B: [Pulse] [Pulse]</p> <p>GATE: [off] [on] [off]</p> <p>ADD: 0 T1 T1+T2</p> <p>SUB: P P-T2 P-T1-T2</p>	<p>Inp A: no function Inp B: Start/Stop Add: Display 0 --> Preset Sub: Display Preset -> 0</p>
FrRun	<p>GATE: [off] [on] [off]</p> <p>ADD: 0 T1 T1+T2</p> <p>SUB: P P-T2 P-T1-T2</p>	<p>Inp A: no function Inp B: no function Control of the timing only via the GATE input Add: Display 0 --> Preset Sub: Display Preset -> 0</p>
Auto	<p>GATE: [off] [on] [off]</p> <p>RESET: [Pulse] [Pulse] [Pulse] [Pulse]</p> <p>PRESET: [Sawtooth]</p> <p>ADD: 0 0 T1 0 T2 T2+T3 0 </p> <p>SUB: P P P-T1 P P-T2 P-T2-T3 P </p>	<p>Inp A: no function Inp B: no function Control of the timing via RESET (manual or electrical) Add: Display 0 --> Preset Sub: Display Preset -> 0</p>

16. Input modes: Frequency meter

Function	Diagram	PNP: Count on rising edge NPN: Count on falling edge																													
A	<table border="1"> <tr> <td>INP A</td> <td>0</td> <td>F_{A0}</td> <td>F_{A1}</td> <td>F_{A2}</td> <td>0</td> <td>X</td> </tr> <tr> <td>Display</td> <td>0</td> <td>0</td> <td>F_{A0}</td> <td>F_{A1}</td> <td>F_{A2}</td> <td>0</td> </tr> </table>	INP A	0	F_{A0}	F_{A1}	F_{A2}	0	X	Display	0	0	F_{A0}	F_{A1}	F_{A2}	0	Inp A: Frequency input Inp B: no function															
INP A	0	F_{A0}	F_{A1}	F_{A2}	0	X																									
Display	0	0	F_{A0}	F_{A1}	F_{A2}	0																									
AsubB	<table border="1"> <tr> <td>INP A</td> <td>0</td> <td>F_{A0}</td> <td>F_{A1}</td> <td>F_{A2}</td> <td>0</td> <td>X</td> </tr> <tr> <td>INP B</td> <td>0</td> <td>0</td> <td>F_{B0}</td> <td>F_{B1}</td> <td>F_{B2}</td> <td>X</td> </tr> <tr> <td>Display</td> <td>0</td> <td>0</td> <td>F_{A0}</td> <td>$F_{A0} - F_{B0}$</td> <td>$F_{A1} - F_{B1}$</td> <td>$-F_{B2}$</td> </tr> </table>	INP A	0	F_{A0}	F_{A1}	F_{A2}	0	X	INP B	0	0	F_{B0}	F_{B1}	F_{B2}	X	Display	0	0	F_{A0}	$F_{A0} - F_{B0}$	$F_{A1} - F_{B1}$	$-F_{B2}$	Inp A: Frequency input 1 Inp B: Frequency input 2 Formula: A-B								
INP A	0	F_{A0}	F_{A1}	F_{A2}	0	X																									
INP B	0	0	F_{B0}	F_{B1}	F_{B2}	X																									
Display	0	0	F_{A0}	$F_{A0} - F_{B0}$	$F_{A1} - F_{B1}$	$-F_{B2}$																									
AaddB	<table border="1"> <tr> <td>INP A</td> <td>0</td> <td>F_{A0}</td> <td>F_{A1}</td> <td>F_{A2}</td> <td>0</td> <td>X</td> </tr> <tr> <td>INP B</td> <td>0</td> <td>0</td> <td>F_{B0}</td> <td>F_{B1}</td> <td>F_{B2}</td> <td>X</td> </tr> <tr> <td>Display</td> <td>0</td> <td>0</td> <td>F_{A0}</td> <td>$F_{A0} + F_{B0}$</td> <td>$F_{A1} + F_{B1}$</td> <td>F_{B2}</td> </tr> </table>	INP A	0	F_{A0}	F_{A1}	F_{A2}	0	X	INP B	0	0	F_{B0}	F_{B1}	F_{B2}	X	Display	0	0	F_{A0}	$F_{A0} + F_{B0}$	$F_{A1} + F_{B1}$	F_{B2}	Inp A: Frequency input 1 Inp B: Frequency input 2 Formula: A + B								
INP A	0	F_{A0}	F_{A1}	F_{A2}	0	X																									
INP B	0	0	F_{B0}	F_{B1}	F_{B2}	X																									
Display	0	0	F_{A0}	$F_{A0} + F_{B0}$	$F_{A1} + F_{B1}$	F_{B2}																									
Quad	<table border="1"> <tr> <td>INP A</td> <td colspan="6"></td> </tr> <tr> <td>INP B</td> <td colspan="6"></td> </tr> <tr> <td></td> <td colspan="6"></td> </tr> <tr> <td>Display</td> <td>0</td> <td>0</td> <td>F_{A0}</td> <td>F_{A1}</td> <td>F_{A2}</td> <td>$-F_{A3}$</td> <td>$-F_{A4}$</td> </tr> </table>	INP A							INP B														Display	0	0	F_{A0}	F_{A1}	F_{A2}	$-F_{A3}$	$-F_{A4}$	A 90° B Inp A: Frequency input 1 Inp B: Reverse direction
INP A																															
INP B																															
Display	0	0	F_{A0}	F_{A1}	F_{A2}	$-F_{A3}$	$-F_{A4}$																								
A/B	<table border="1"> <tr> <td>INP A</td> <td>0</td> <td>F_{A0}</td> <td>F_{A1}</td> <td>0</td> <td>0</td> <td>X</td> </tr> <tr> <td>INP B</td> <td>0</td> <td>0</td> <td>F_{B0}</td> <td>F_{B1}</td> <td>F_{B2}</td> <td>X</td> </tr> <tr> <td>Display</td> <td>0</td> <td>0</td> <td>0</td> <td>F_{A0} / F_{B0}</td> <td>F_{A1} / F_{B1}</td> <td>0</td> </tr> </table>	INP A	0	F_{A0}	F_{A1}	0	0	X	INP B	0	0	F_{B0}	F_{B1}	F_{B2}	X	Display	0	0	0	F_{A0} / F_{B0}	F_{A1} / F_{B1}	0	Inp A: Frequency input 1 Inp B: Frequency input 2 Formula: A/B								
INP A	0	F_{A0}	F_{A1}	0	0	X																									
INP B	0	0	F_{B0}	F_{B1}	F_{B2}	X																									
Display	0	0	0	F_{A0} / F_{B0}	F_{A1} / F_{B1}	0																									
(A-B)/A	<table border="1"> <tr> <td>INP A</td> <td>0</td> <td>F_{A0}</td> <td>F_{A1}</td> <td>0</td> <td>0</td> <td>X</td> </tr> <tr> <td>INP B</td> <td>0</td> <td>0</td> <td>F_{B0}</td> <td>F_{B1}</td> <td>F_{B2}</td> <td>X</td> </tr> <tr> <td>Display</td> <td>0</td> <td>0</td> <td>100%</td> <td>$F_{A0} \% F_{B0}$</td> <td>$F_{A1} \% F_{B1}$</td> <td>0</td> </tr> </table>	INP A	0	F_{A0}	F_{A1}	0	0	X	INP B	0	0	F_{B0}	F_{B1}	F_{B2}	X	Display	0	0	100%	$F_{A0} \% F_{B0}$	$F_{A1} \% F_{B1}$	0	Inp A: Frequency input 1 Inp B: Frequency input 2 Formula: (A - B)/A x100								
INP A	0	F_{A0}	F_{A1}	0	0	X																									
INP B	0	0	F_{B0}	F_{B1}	F_{B2}	X																									
Display	0	0	100%	$F_{A0} \% F_{B0}$	$F_{A1} \% F_{B1}$	0																									

17. Output operations

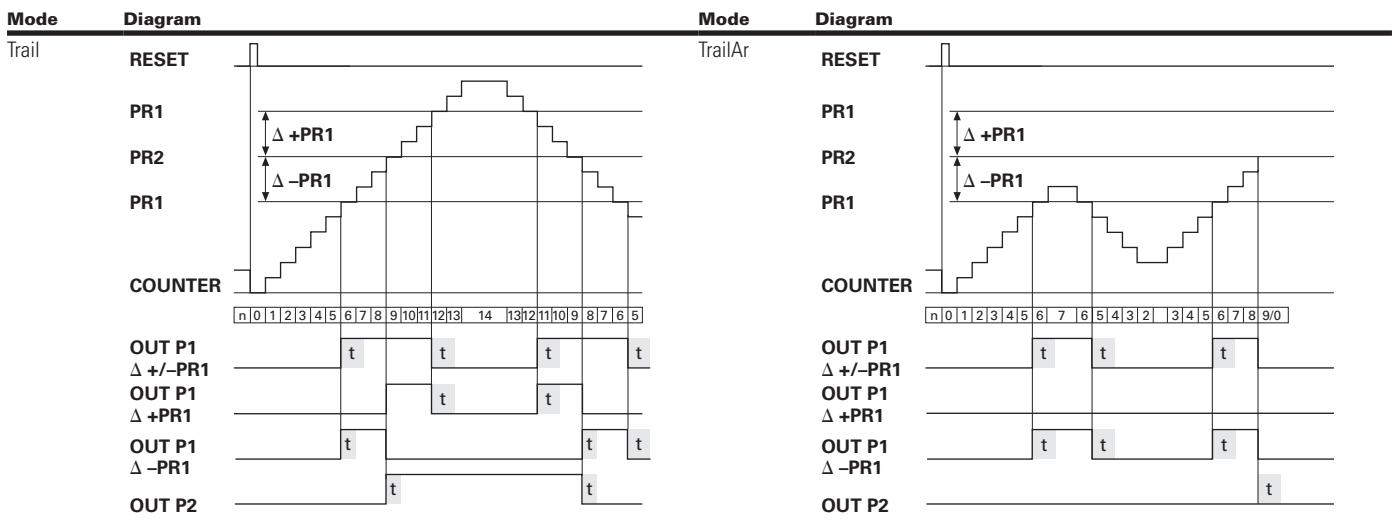
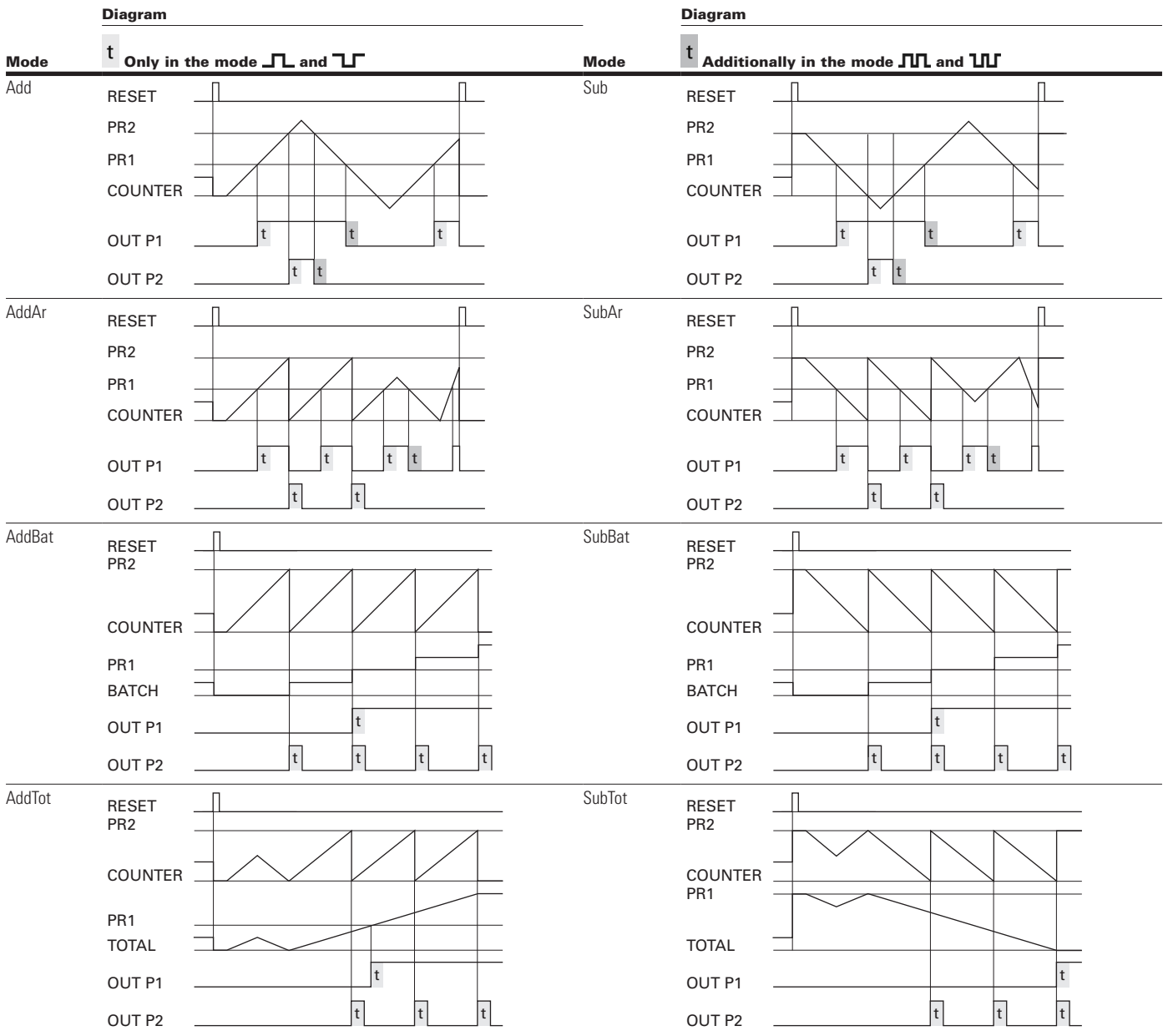

18. Dimensional drawings (mm)

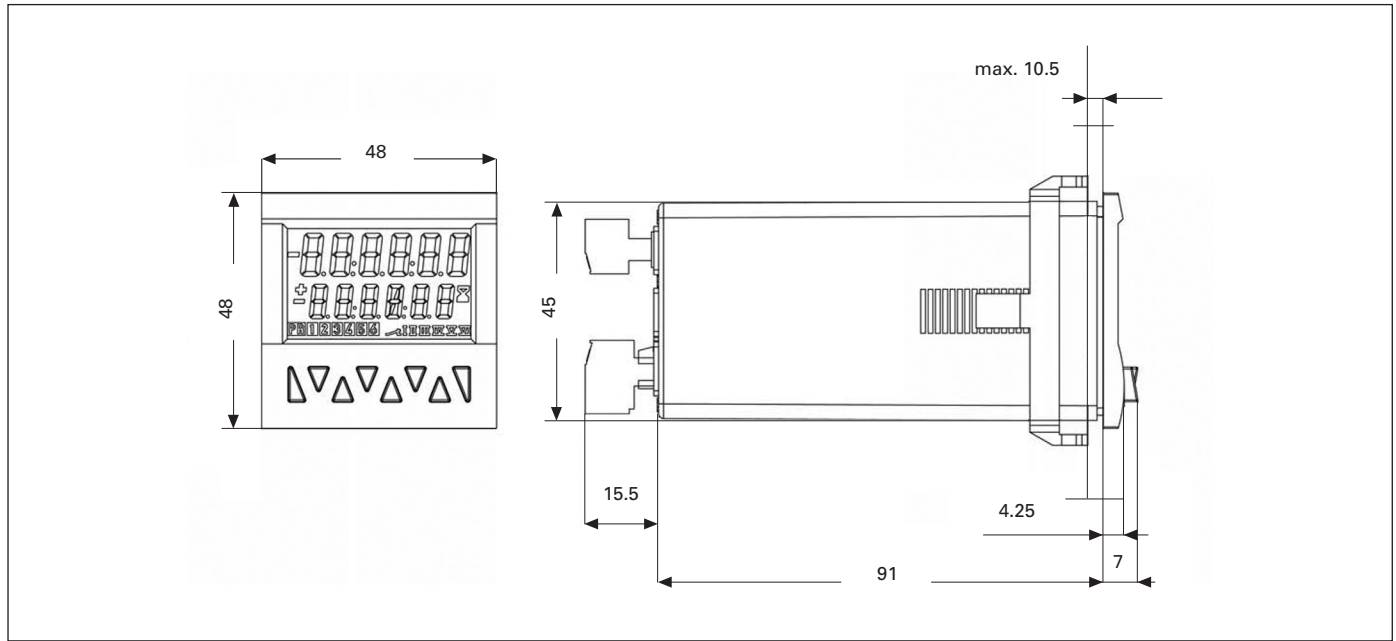

Figure 2. Dimensions

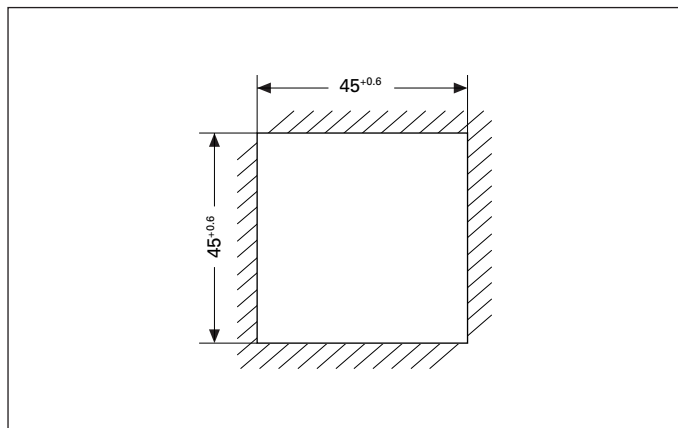

Figure 3. Panel cut-out

E5-648-C242x
electronic preset counter
with two presets

Instruction leaflet IL05407002E
Effective October 2010

Notes:

Eaton Corporation
Electrical Sector
1111 Superior Ave.
Cleveland, OH 44114
United States
877-ETN-CARE (877-386-2273)
Eaton.com

© 2010 Eaton Corporation
All Rights Reserved
Printed in USA
Publication No. IL05407002E / Z9871
October 2010



**PowerChain
Management®**

PowerChain Management is a registered trademark of Eaton Corporation.

All other trademarks are property of their respective owners.