



Designers' Manual

Contents

1	Overview of Xgen series
2	Part numbering system
3	Installation considerations
4	Xgen DOs and DON'Ts
5	Theory of operation
6	Xgen configuration
7	<i>powerMod</i> operation
8	<i>powerMod</i> signals
9	<i>powerPac</i> operation
10	<i>powerPac</i> (global) signals
11	<i>powerPac</i> options
12	Power ratings
13	Reliability
14	Safety
15	EMC
16	Connectors
17	Mechanical specifications
18	Configuring Xgen

This Xgen Designers' Manual has been prepared by Excelsys experts to assist suitably qualified engineers and technicians in understanding the correct system design practices necessary to achieve maximum versatility and performance from any of the Xgen series family of products.

Section 1 Overview of Xgen series

The Xgen series allows users to instantly configure high efficiency, off-line power supplies. Although very small in size, (40.4mm high, 260mm long and either 89mm or 127mm wide) the Xgen series provides up to 1,200W of output power. The chassis has 4 or 6 slots and can provide up to 12 isolated outputs.

A complete power supply is configured by selecting and inserting up to six same length slide-in output assemblies called *powerMods* incorporating high efficiency switching techniques and leading edge technologies from Excelsys and available in a wide array of output voltages and power levels. The net result is a power supply that offers the advantages of a custom supply, but is assembled from standard and modular building blocks continuing the Excelsys tradition of industry leading configurable power supplies.

Manufactured in world class power supply facilities under Excelsys control, the Xgen series is completely user configurable. If output requirements change, i.e., more power or a different output voltage is needed, upgrading is easy: simply unlock a single screw and replace the slide-in *powerMod* assembly with the preferred alternative. Allowing additional flexibility, *powerMods* can be connected in parallel to increase output power, or in series for higher voltages (subject to staying within isolation ratings and giving due consideration to any SELV requirements).

A user-friendly interface on connector J3 of each *powerMod* provides control and output sequencing capability, in addition to useful status indicators. Please consult our Excelsys applications team if you have other special requirements.

The Xgen series power supplies combine feature-laden front-ends (*powerPacs*) with slide-in output converters (*powerMods*). The plug-together architecture facilitates 'instant' custom power solutions with industry leading 15W/in³ power density and up to 90% conversion efficiency. Available in two package sizes, with a variety of application specific *powerPacs*, the Xgen series provides a standard off-the-shelf solution for specific application requirements.

The tables overleaf summarise various model families in the Xgen series together with a summary of the outline specifications for each model.



powerPacs

General Applications (4slot package, 89mm wide)

Family	MODEL	Watts
Xlite	XLA	200W
	XLB	400W
	XLC	600W
	XLD	750W

General Applications (6slot package, 127mm wide)

Family	MODEL	Watts
Xcite	XCA	400W
	XCB	700W
	XCC	1000W
	XCD	1200W
	XCE	1340W

Medical Applications (4slot package, 89mm wide)

Family	MODEL	Watts
Xmite	XMA	200W
	XMB	400W
	XMC	600W
	XMD	750W

Medical Applications (6slot package, 127mm wide)

Family	MODEL	Watts
Xvite	XVA	400W
	XVB	700W
	XVC	1000W
	XVD	1200W
	XVE	1340W

High Temperature (6slot package, 127mm wide)

Family	MODEL	Watts
Xhite	XHA	400W
	XHB	600W

Low Acoustic Noise (4slot package, 89mm wide)

Family	MODEL	Watts
Xkite	XKA	200W
	XKB	400W
	XKC	600W

Low Acoustic Noise (6slot package, 127mm wide)

Family	MODEL	Watts
Xqite	XQA	400W
	XQB	900W
	XQC	1200W

Medical Low Acoustic Noise (4slot package, 89mm wide)

Family	MODEL	Watts
Xrite	XRA	200W
	XRB	400W
	XRC	600W

Medical Low Acoustic Noise (6slot package, 127mm wide)

Family	MODEL	Watts
Xzite	XZA	400W
	XZB	900W
	XZC	1200W

See Section 12:Power Ratings for detailed *powerPac* ratings

powerMods

MODEL	Vmin	Vnom	Vmax	I _{max}	I _{min}	Type	Watts	
Xg1	1.0	2.5	3.6	50A	0A	A	125W	
Xg2	1.5	5.0	6.0	40A	0A	A	200W	
Xg3	4.0	12.0	15.0	20A	0A	A	240W	
Xg4	8.0	24.0	30.0	10A	0A	A	240W	
Xg5	8.0	48.0	58.0	6A	0A	A	288W	
Xg7	5.0	24.0	30.0	5A	0A	A	120W	
Xg8	V1	5.0	24.0	28.0	3A	0A	B	72W
	V2	5.0	24.0	28.0	3A	0A	B	72W

See Section 12:Power Ratings for detailed *powerMod* ratings

Standard Features

- Input Voltage: 85V to 264Vac 47 to 63 Hz
- Outputs: 6 slots (up to 12 outputs)
- Full power output to 40°C; Derating to 70°C
- Low inrush current
- Conducted EMI meets EN 55022 Level B
- AC Fail status signal
- Output Sequencing capability
- Global shutdown capability
- Overcurrent protection standard on all outputs.
- Overvoltage protection on all *powerMod* outputs
- Overtemperature limiting on all *powerMods*
- Safety Agency Approvals: CE Mark, UL, CSA
- DC OK (Power Good) status signal
- Wide output voltage adjustment range
- RoHS compliant

Optional Features

- Thermal Signals suite (Over Temp and FanFail signals)
- Reversed fan airflow direction

Section 2 Part numbering system

The part numbering system (explained below) clearly identifies which *powerMods* are factory installed into particular *powerPacs*. This is also clearly indicated on the output label situated on top of the power supply.

Full specifications for each model are given in the relevant family datasheets,

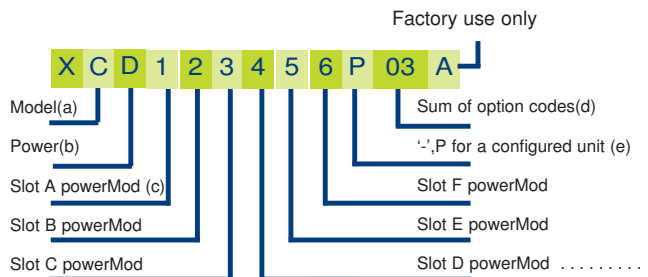

- (a) Letter refers to relevant Xgen family 'C' for cite, 'V' for vite etc
- (b) Letter refers to power level within family, D for 1200W in Xcite
- (c) Number refers to powerMod type. '1' for Xg1, '2' for Xg2 etc, '0' if unused
- (d) Number refers to Option codes, -01 for temps alarms, -02 for reverse fan
- (e) 'P' for configured (voltage settings etc), '-' for non configured

Section 3 Installation considerations

Xgen series models may be mounted on any of three surfaces using standard M4 screws. The chassis comes with four mounting points on the base; maximum allowable torque is 2Nm. The maximum penetration depth is 6mm. Additionally, the fleximount™ system on both side walls of the powerPac chassis facilitates flexible mounting. See Section 17 for further information.

When selecting a mounting location and orientation, the unit should be positioned so air flow is not restricted. Maintain a 50mm minimum clearance at both ends of the Xgen power supply and route all cables so airflow is not obstructed. The standard unit draws air in on the input side and exhausts air out the load side. If airflow ducting is used, avoid sharp turns that could create back pressure. The fan moves 8.78 CFM of air.

Avoid excessive bending of output power cables after they are connected to the Xgen *powerMods*. For high-current outputs, use cable-ties to support heavy cables and minimize mechanical stress on output studs. Be careful not to short-out to neighboring output studs. Xgen *powerMods* are supplied with spring washers on all output screws. These (or equivalents) should be used and thread locking compounds are not required. The maximum torque recommended on output connectors is 4Nm. Avoid applications in which the unit is exposed to excessive shock or vibration levels that exceed the specified levels. In such applications, a shock absorption mounting design is required.

Section 4 Xgen DOs and DON'Ts

- Always fill all output slots of the Xgen. If a slot is not filled with a *powerMod*, it should be filled with an Empty Slot Cover (part numbers XB1, XB2 or XB3). Empty Slot covers are plastic assemblies whose main function is to fill up an empty slot. Excessive airflow escape from an empty slot may degrade thermal performance, and result in overheating and damage to the Xgen unit. Refer to Section 12 for optimum positioning of *powerMods*.
- Do not unplug *powerMods* while input power is applied to the powerPac. The Xgen series is not designed for hot-plug applications.

- Do not restrict airflow to the unit. The cooling fan draws air into the unit and forces it out at the output terminals.
- Always ensure that output screws are properly torqued before applying power to the *powerPac*.
- Positive and Negative power cables should be run next to each other to minimize inductance.
- Wait 4 minutes after shutting off power before inserting or removing *powerMods*.
- Xgen assemblies do not have user serviceable components. They must be returned to the factory for repairs. Contact Customer Service for a RMA number before returning the unit. Do not attempt to repair or modify the power supply in any manner other than the exchange of *powerMods* as described in this Designers' Manual.
- Use proper size wires to avoid overheating and excessive voltage drop.

Section 5 Theory of operation

The Xgen is comprised of an appropriate *powerPac* and a selection of *powerMod* DC output modules selected to deliver the exact volts and amps requirements of the the system designer. See Operational Block Diagram below.

The Xgen *powerPac* modules consist of a fan-cooled semi-enclosed chassis containing circuitry for an off-line single phase AC front end, EMI filter, cooling fan, customer interface and associated housekeeping circuits. Input AC mains voltage (L1/N, L2 and GND) is applied to an IEC320 type input connector and then through an EMI filter designed to meet EN 55022 Level B. For medical applications, the EMI filter also ensures the the power supply meets the low earth leakage current requirements of EN60601-1

At start-up, inrush current is limited by an active soft-start circuit integrated with the power rectifier circuitry. This stage is then followed by a high frequency switching input current shaping boost converter feeding the ZVS (Zero Voltage Switching) resonant switching stage. The ZVS stage supplies power to a variety of *powerMod* assemblies that provide the desired low voltage, regulated outputs. Conversion in the output assemblies is achieved by the most advanced high efficiency converters resulting in reduced size for magnetics and capacitors; excellent line and load regulation; wide adjustment range for output and low EMI/RFI emission.

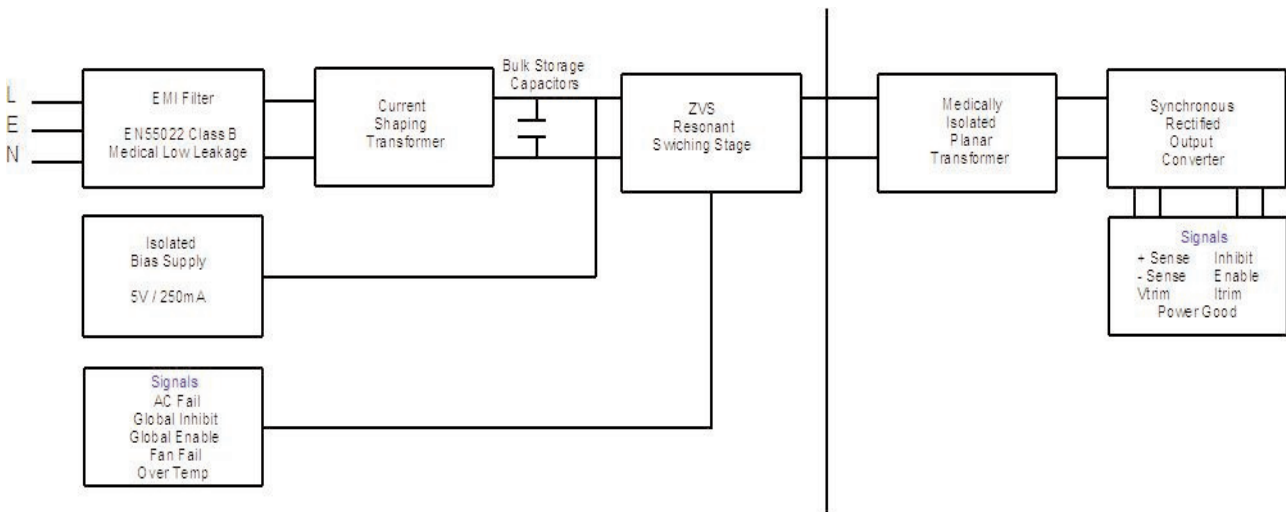

Operational Block Diagram of Xgen Series

At initial power-up, the Xgen outputs are disabled to eliminate inrush current and a low-power flyback converter operating with PWM currentmode control converts the high voltage DC bus into regulated low voltage to power the internal house-keeping circuits and cooling fans. Once the bus potential is within operating parameters, the AC Fail signal is activated indicating that the input power is OK, and allows the installed *powerMod* outputs to come up. An auxiliary bias supply of 5 Vdc rated at 250mA is provided for peripheral use on interface connector J2. In the case of medically approved supplies, this bias supply has medical isolation (4000VAC).

Outputs may be either globally enabled or inhibited via contact closure signals applied to J2.

Section 6 Configuration (and Reconfiguration)

powerMods may be easily added, replaced, or moved by sliding the assemblies in or out of a powerPac chassis.

Prior to removing or installing a *powerMod* module, remove power from the *powerPac* and wait 4 minutes. Failure to do so can result in personal injury and/or damage to the supply. Take standard ESD precautions when handling *powerMods*.

Configuring the Xgen is as easy as 1,2,3!

1. Select the appropriate *powerMods* for your application.
2. Calculate your power requirements
3. Select your appropriate powerPac for power and application from the wide range of powerPacs listed on page 2. See Section 18 for Configuration examples

Removing *powerMods*

powerMods may be removed by removing the screw on the top surface. Once this screw has been removed the *powerMod* will slide out of the chassis. Once a *powerMod* has been removed, the empty slot MUST be filled with either another *powerMod* or an empty slot cover. If the slot is left empty, it will provide an airflow escape and may cause inadvertent shutdown of the unit.

Installing *powerMods*

powerMods may be installed in empty slots by simply sliding in the new *powerMod*, pushing the module 'home' until the mounting bracket lines up with the hole in the Top Panel, then securing the module with the M3 x 6 countersunk screw provided. Power and interface connections can be made after the *powerMod* has been installed.

powerMods may be paralleled for more power using bus bars (paralleling Links) across the positive and negative output terminals. See Section 7

Section 7 *powerMod* operation

The Xgen series of products have been designed to allow maximum flexibility in meeting the unique requirements of individual users. The inherent flexibility resulting from modularity concepts is further enhanced by this flexibility. Although the products are very versatile, care should always be taken to ensure that the proper procedures are followed.

Voltage Adjustment

The Xgen series has been designed with maximum user flexibility as a key objective. With regards to voltage adjustment this has been achieved by the wide range of adjustment on each of the *powerMod* models. Voltage adjustment may be achieved by:

1. Front-panel potentiometer adjustment
2. Remote resistive programming
3. Remote voltage programming

See diagrams for details on external connections to the V trim pin (J3 pin3) required for remote voltage programming.

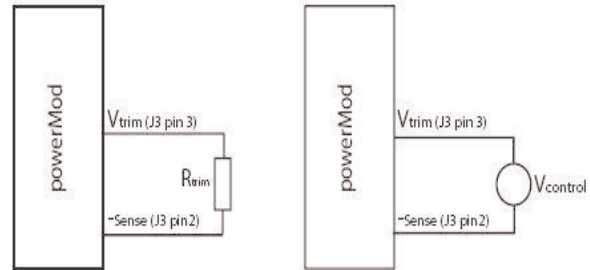

Remote Voltage Programming using a Voltage Source

Using an external Voltage source ($V_{control}$), the *powerMod* output voltage may be adjusted over a wide range. The *powerMod* output voltage may be programmed by referring to the Voltage Programming graph and applying formula below to set the *powerMod* output voltage to the required level.

$$V_{output} = K \times V_{control} \quad (1)$$

The appropriate K factor for different *powerMods* are in Voltage Programming table.

Important: $V_{control}$ must not exceed 2.5V.

e.g. V_{nom} of Xg3 is 12V, trim range is 3.6V to 15.0V

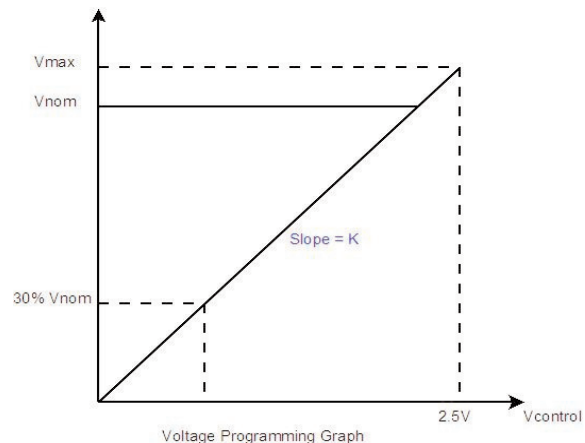

Voltage Programming Table	
powerMod	K
Xg1	1.5
Xg2	2.5
Xg3	6.25
Xg4	12.5
Xg5	24.25

Example

Using a *powerMod* Xg4, what external voltage must be applied to Vtrim pin in order to set *powerMod* output voltage to 20V.

PowerMod	Vmin	Vnom	Vmax	I _{max}	I _{limit adjust} Min Max	Current Limit Onset SC*	I foldback	V _{trim} range Min Max	I _{trim} range Min Max	OVP 1 Tracking % of Vset	OVP 2 Latching % of Vmax	Remote Sense	J3 Signals	
Xg1	1.5V	2.5V	3.6V	50A	0A 55.0A	55.0A 58.0A	Yes	1.0V 3.9V	0A 55.0A	110-115%	110-125%	0.5V	+Sense V _{trim} Inhibit +PG	-Sense I _{trim} Enable -PG
Xg2	3.2V	5.0V	6.0V	40A	0A 44.0A	44.0A 46.0A	Yes	1.5V 6.6V	0A 44.0A	110-115%	110-125%	0.5V	+Sense V _{trim} Inhibit +PG	-Sense I _{trim} Enable -PG
Xg3	6.0V	12.0V	15.0V	20A	0A 22.0A	22.0A 23.0A	Yes	3.6V 16.5V	0A 22.0A	110-115%	110-125%	0.5V	+Sense V _{trim} Inhibit +PG	-Sense I _{trim} Enable -PG
Xg4	12.0V	24.0V	30.0V	10A	0A 11.0	11.0A 12.0A	Yes	7.2V 30.0V	0A 11.0	110-115%	110-125%	0.5V	+Sense V _{trim} Inhibit +PG	-Sense I _{trim} Enable -PG
Xg5	28.0V	48.0V	58.0V	6A	0A 6.6A	6.6A 7.0A	Yes	7.2V 58.0V	0A 6.6A	110-115%	110-125%	0.5V	+Sense V _{trim} Inhibit +PG	-Sense I _{trim} Enable -PG
Xg7	5.0V	24.0V	30.0V	5A	No	5.5A 6.0A	No	No	No	No	110-125%	No	+PG -PG Inhibit Common	
Xg8 V1	5.0V	24.0V	28.0V	3A	No	3.3A 4.0A	No	No	No	No	110-125%	No	V1	V2
Xg8 V2	5.0V	24.0V	28.0V	3A	No	3.3A 4.0A	No	No	No	No	110-125%	No	+PG -PG Inhibit Common	+PG -PG Inhibit Common

V_{output} = 20V, K=12.5
Using equation (1); $V_{output}/K = V_{control}$
20V/12.5 = 1.6V.

$$V_{control} = 1.6V$$

Remote Voltage Programming using a Resistor.

The *powerMod* output voltage can be adjusted downward using a remote potentiometer, or reduced, using an external resistance.

Calculation of the the external resistance depends on the actual initial voltage setting of the *powerMod* (via the onboard potentiometer). The preferred method is to set the *powerMod* voltage to its maximum rating. e.g. Xg4 set to 30V. This will allow the widest possible adjustment range of the output voltage.

powerMod set to V_{max}
For modules Xg1 and Xg2

$$R_{trim} = \frac{[3700V_{out} - 250K]}{[2.5K - V_{out}]} \quad (2)$$

Example.

Using a *powerMod* Xg4, determine the resistance value to be applied to V_{trim} pin in order to set *powerMod* output voltage to 20V.

K for Xg4 = 12.5
V_{out} = 20V
Using equation (2)

$$R_{trim} = 6300 \text{ ohm}$$

Alternatively if the *powerMod* voltage is set to new level via the on-board potentiometer to another level e.g. 21V then the following formula must be used to calculate the value of R_{trim}

For powerMod Xg1 and Xg2

$$R_{trim} = \frac{V_{out} [(3700 + 10KVp(1-Vp)) - K(100Vp+67.5)]}{K(Vp + 0.675) - V_{out}} \quad (3)$$

For powerMod Xg3, Xg4 and Xg5

$$R_{trim} = \frac{V_{out} [(3700 + 10KVp(1-Vp)) - K(100Vp+127.50)]}{[K(Vp + 1.275) - V_{out}]} \quad (4)$$

where Vp is the *powerMod* setpoint voltage expressed as a

proportion of the total trim range.

$$Vp = \frac{(V_{set} - V_{min})}{(V_{max} - V_{min})} \quad (5)$$

Example.

To set *powerMod* Xg4 to 15V when *powerMod* Vset is 21V

Using equation (5) $Vp = \frac{(21-12)}{(30-12)}$

$$Vp = 0.5$$

K= 12.5
V_{out} =15V

Using equation (4)

$$R_{trim} = \frac{V_{out} [(3700 + 10KVp(1-Vp)) - K(100Vp+127.5)]}{[K(Vp + 1.275) - V_{out}]}$$

$$R_{trim} = 7478 \text{ ohm}$$

The power rating of the trim resistor can be as low at 100mW

Over Current Protection (OCP)

A variety of over current protection methods are possible with the Xgen series. See the *powerMod* table which indicates the available current limit modes on each *powerMod*.

powerMods Xg1 to Xg5 can have Straight-line current limit or Foldback current limit. See powerMod table for nominal current limit values.

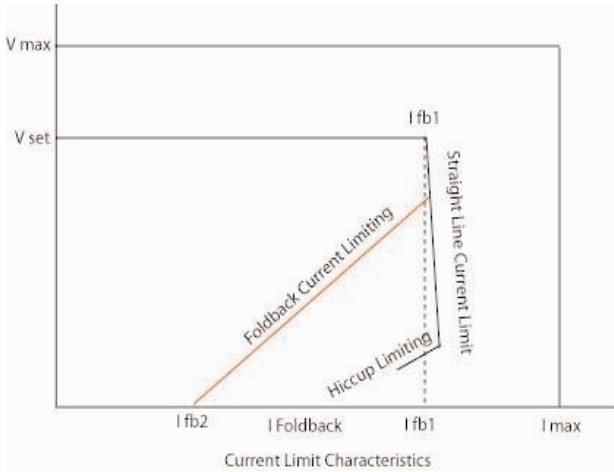

Simple external application circuits may be used to achieve programmable foldback current and user programmable current limit levels (reduced). See Current Limit Programming diagrams and Foldback Programmable Current Limit diagram. The default current limit characteristic is Straight Line Current Limit.

Programming Current Limit

The current limit can be programmed to your requirements (in both Straight line and Foldback modes).

Straight line Current Limit can be programmed using an external voltage source or resistor/potentiometer. Connection between the Itrim pin (J3 pin4 and the -Vout terminal will set the current limit to the desired level.

Straight Line Current Limit Using a Voltage Source.

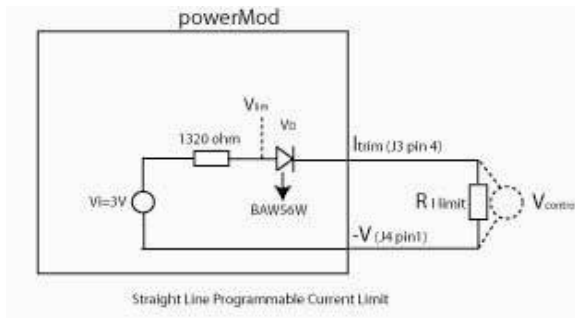

The formula below will calculate the required external control voltage required to set the current limit of a powerMod:

$$V_{control} = F I_{lim} - VD + 1 \tag{6}$$

Where F is a conversion factor for each powerMod.

VD is the voltage drop across BAW56W. This can be assumed to be 0.5V for calculations, however it will vary slightly due to temperature. Refer to BAW56W datasheet for further details.

Example:

To set the current limit of Xg1 to 20A, determine the external voltage to be applied to the Itrim pin.

Current Limit Table	
powerMod	F
Xg1	0.026
Xg2	0.0308
Xg3	0.09108
Xg4	0.14935
Xg5	0.2987

I_{lim} = 20A
 F = 0.0308 for Xg1
 VD = 0.5V
 Using equation (6)

$$V_{control} = 1.116V$$

Note that application of any voltage >2.5V to Itrim will not increase current limit beyond the powerMods normal current limit.

Straight Line Current Limit Using an External Resistor.

The formula below will calculate the required external resistor value required to set the current limit of a powerMod:

$$R_{I\ limit} = 1320 \left[\frac{(3-VD)}{2 \cdot F I_{lim}} - 1 \right] \tag{7}$$

Example:

To set the current limit of Xg2 to 30A, what resistance must be placed between the Itrim pin and -V.

I_{lim} = 30A
 F = 0.0308 for Xg1
 VD = 0.5V
 Using equation (7)

$$R_{I\ limit} = 1747\ \text{ohm}$$

Foldback Current limit Programming

Foldback Current Limit can be achieved using the circuit below. The onset of Foldback current limit (I_{fb1}) can be programmed using the formula below as can the actual end point (I_{fb2}).

To set the final Foldback current limit point (I_{fb2}), the value R₁ in parallel with R₂ is equivalent to R_{I limit} in the previous Straight Line current limit example.

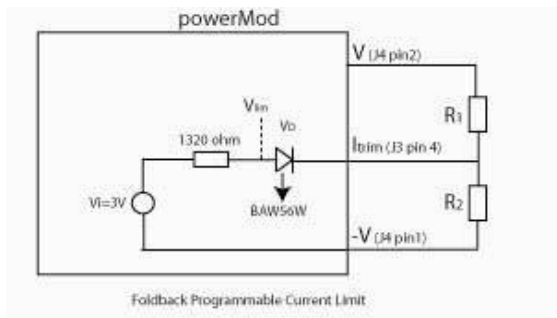

To set I_{fb1} point, we must calculate the ratio of R₁ to R₂. To get the value of R₁:

$$R_1 = \frac{(R_{I\ limit})V_{out}}{[F I_{fb1} (1 + \frac{R_{I\ limit}}{1320}) - 2 \frac{R_{I\ limit}}{1320} + 1 - VD]} \tag{8}$$

$$R2 = \frac{(R1)(R_{I\ limit})}{R1 - R_{I\ limit}} \quad (9)$$

Example

To set the foldback current limit of an Xg2 set at 5V to the following levels, $I_{fb1}=30A$ and $I_{fb2}=20A$, determine the values of $R1$ to $R2$. required.

V_{out} 5V
 $F = 0.0308$
 $I_{fb1}=30A$
 $I_{fb2}=20A$
 $VD=0.5V$

To set I_{fb2} to 20A, we need the to set $R_{I\ limit}$ equivalent parallel resistance of $R1$ in parallel with $R2$.

Using equation (7)

$$R_{I\ limit} = 1320 \left[\frac{[(3-VD) - 1]}{(2-F)lim} \right]$$

$$R_{I\ limit} = 1064 \text{ ohm.}$$

To calculate the ratio of $R1$ to $R2$ use the formula above

Use equation (8)n to get the value of $R1$

$$R1 = 9556 \text{ ohm}$$

Use equation (9) to get the value of $R2$

$$R2 = 1197 \text{ ohm}$$

Over Voltage Protection (OVP)

Over-voltage protection is implemented on each Xgen *powerMod* output as a two-level scheme, where the 1st level of protection tracks the set voltage V_{set} and the 2nd level of protection is set at a fixed level.

1st Level: 110-115% of V_{set} (where V_{set} is less than V_{max} of *powermod*. This is only available on *powerMods* Xg1-Xg5.

2nd level: OVP level is fixed relative to V_{max} 110-125% (Latching).

2nd Level Overvoltage protection is Latching and it may be reset by removing and reinstating AC power from the Xgen *powerPac* input.

Power Limit.

Each *powerMod* has a number of levels of protection in order to ensure that Xgen is not damaged if used in overload conditions. See graph

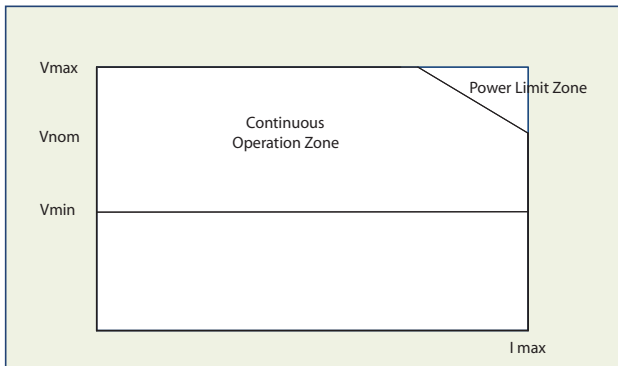

When V_{set} is less than or equal to V_{nom} , current limit is employed at the current limit set point. However if V_{set} is

greater than V_{nom} , power limit is employed to ensure that the *powerMods* does not exceed its power rating. e.g. Xg4 is adjustable between 12V and 30V. I_{max} is 10A. Power rating is 240W. At 24V the *powerMod* can deliver 10A continuously, i.e 240W. At 30V, the *powerMod* can still deliver 240W, however this equates to 8A continuous.

Remote Sense

To compensate for voltage drops in the output leads, use remote sensing. Remote sensing is available on all single output, and on the first output (V1) of dual output module.

Remote sensing may be implemented by connecting the Positive Sense pin (J3 pin1) to the positive side of the remote load and the Negative Sense pin (J3 pin2) to the negative side of the remote load. The maximum line drop, which can be compensated for by remote sensing, is 0.5V, subject to not exceeding the maximum module voltage at the output terminals.

- Observe the following precautions when remote sensing:
1. Use separate twisted pairs for power and sense wiring.
 2. Route the sensing leads to prevent pick up, which may appear as ripple on the output.
 3. Never disconnect the output power rail with the sensing still connected to the load.

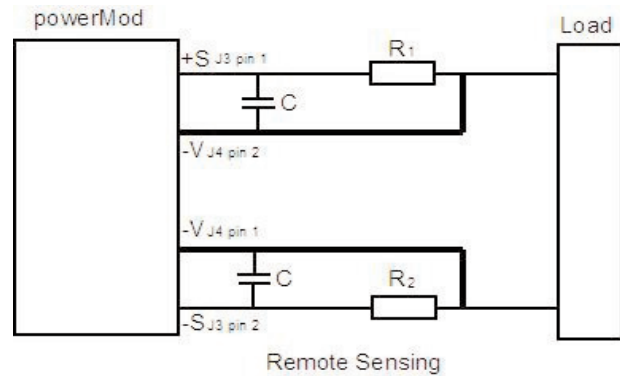

In certain applications where there is a high dynamic impedance along the power leads to the sensing point; remote sensing may cause system instability. This system problem can be overcome by using resistors in the sense leads (Positive sense lead: $R1 = 100\text{ohm}$, Negative sense lead: $R2=10\text{ohm}$), together with local AC sensing, by using 22uF capacitors between the remote sense pins and the output terminals.

The resistance of the power cables must be so that the voltage drop across the cables is less than 0.5V (to ensure remote sensing operates correctly.

$$R_{cable} < \frac{0.5}{I_{out}}$$

e.g. for an Xg2, 5V/40A. The R_{cable} must be less than 12.5mohms

Measurement of Ripple & Noise

As with all switched mode power supplies, it is important to ensure that the correct method is used to verify ripple & noise. Care should be taken to ensure that a loop antenna is not formed by the tip and ground lead of the oscilloscope probe as this would lead to erroneous readings consisting

mainly of pickup from remnant radiation in the vicinity of the output connectors. Excelsys recommends the use of a x1 probe with the ground sheath of the probe tip used for ground connection.

In some applications, further erroneous readings may result from CM currents. These can be reduced by looping a few turns of the scope lead through a suitable high permeability ferrite ring.

As most loads powered by a power supply will have at least small values of differential capacitors located near the load, Excelsys also recommends the use of small value of capacitance (approx 1uF) positioned at the point of measurement.

Minimising System Noise

There are a number of causes of poor system noise performance. Some of the more common causes are listed below.

- Insufficient de-coupling on the PCB or load
- Faulty wiring connection or poor cable terminations
- Poor system earthing

There are some simple steps to eliminate, reduce or identify the causes of high frequency noise

- Is the noise conducted or radiated? If changing the position of the power supply or screening improves performance, the noise is likely to be radiated. See Section 15. EMC: Guidelines for Optimum EMC Performance
- Twist all pairs of power and sense cables separately
- Ground connections (zero Volt) should be made with the shortest possible wiring via a capacitor to the nearest point on the chassis.

Series Connection of *powerMod* outputs

It is possible to connect modules in series to increase output voltage.

Outputs are rated SELV (Safety Extra Low Voltage), that is, that output voltages are guaranteed to less than 60 volts. Stacking output modules can exceed SELV, the user must take appropriate precautions. It is good practice to stack modules with similar output current limits, so that in the case of short circuit the outputs collapse together,

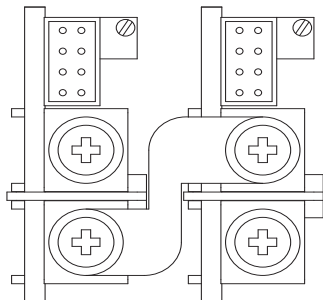

If remote sensing is required, the exterior sense connections should connect to the load at point of use, and the interior connections to the local sense. Special links for series connection modules (part number XS1) to reduce wiring complexity can be specified and fitted by the installer or added at the factory.

Parallel Connection of *powerMod* outputs

powerMods may be paralleled to increase output current. Only *powerMods* of the same type may be paralleled and the installer should adjust the setting on each *powerMod* sepa-

rately to the same value. i.e within 0.1% of the set voltage. Excelsys supplies special parallel link connection bars (part number XP1) for parallel connection to reduce wiring complexity. These can be fitted by the installer or added at the factory

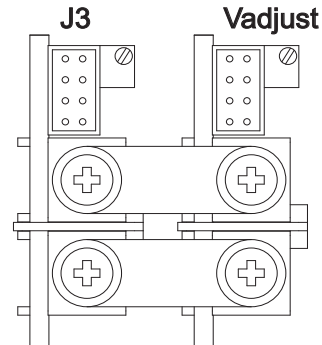

There are two methods of parallel connection.

Level 1 Paralleling.

Current Share (*powerMod* DIP switch Ishare OFF). does not force current sharing.(not recommended)

Level 2 Paralleling: (Recommended)

This ensures current sharing between paralleled modules and is the recommended mode for paralleling *powerMods*. Current Sharing is proportional to the dV (difference between the voltage settings of the *powerMods*). When connecting *powerMods* in parallel, please observe the following steps.

- Attach the negative Parallel Link.
- For Level 2 Paralleling, ensure that the *powerMod* DIP switch on each *powerMod* is switched to Ishare ON
- Set the voltage of *powerMod* 1 to the correct output required.
- Measure the voltage difference (dV) between the positive terminals of the *powerMods* and adjust powerMod 2 to minimise dV. (typically 5mV)
- Attach the positive parallel link

The percentage of current sharing is calculated as follows/

$$I_{Share\ error\%} = \frac{10000dV}{1.5V_{max}} \quad (10)$$

Remote Sense can be implemented as with a single *powerMod*. Simply connect the sense pins of the paralleled *powerMods*. Bring the sense connections from one of the *powerMod* to the load.

For Remote Voltage Adjustment (via Vtrim pin) of *powerMods*, please contact factory.

powerMod Start-Up and Shutdown

powerMods are designed such that when input power is applied, all outputs rise to their set point voltage simultaneously.

Like wise, when input power is removed all outputs commence to drop simultaneously and reach Zero potential simultaneously.

Outputs can be sequenced using the enable function in order to allow controlled start up if required.

See plots for start-up and shutdown characteristics

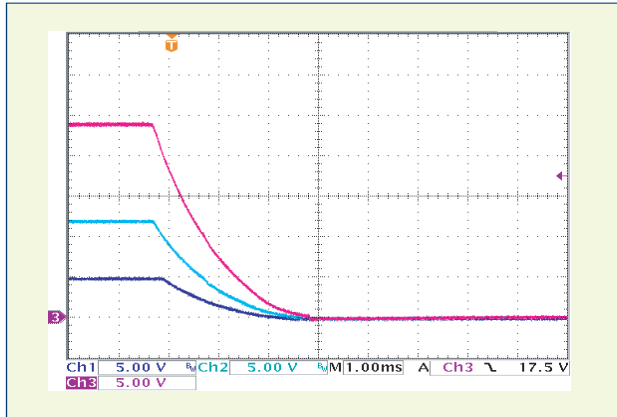
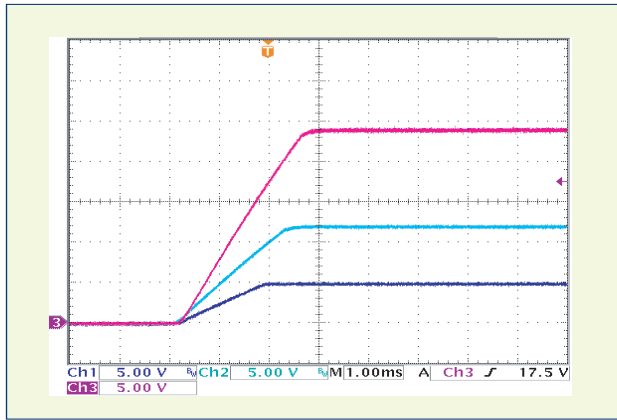

Section 8 powerMod Signals

powerMod Enable/Inhibit

Each *powerMod* may be enabled/inhibited by means of an appropriate signal applied to an opto-isolated input on pins J3 pin 5 (positive) and J3 pin 6 (negative), on powerMods Xg1 to Xg5. Inhibit is available by means of an appropriate signal applied to an opto-isolated input on J3 pin7 on Xg7, on J3 pin 3 and pin 7 on Xg8. The output voltage of the powerMod will be fully inhibited to 0V.

	Xg1 to Xg5	Xg7, Xg8
Maximum signal input voltage	12V.	0.8V
Minimum signal input voltage	3V.	0V
Minimum current required is	1.7mA.	

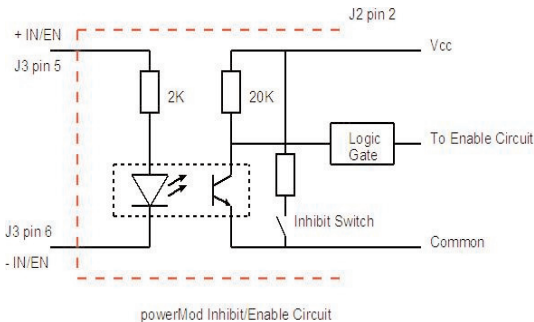

The *powerMod* can be configured to be NORMALLY ON or NORMALLY OFF by appropriate setting of the DIP switch on the *powerMod*. (note the default mode is NORMALLY ON). INHIBIT ON/ENABLE OFF is the the standard position. (Switch is white). The *powerMod* will deliver output voltage, when mains is applied. (and *powerPac* is enabled). The *powerMod* requires an external signal to disable the output. e.g. 5V applied between +IN/EN and -IN/EN pins will disable

the *powerMod*, (bring output to 0V).

This may be changed to 'ENABLE' by setting of the DIP switch to the INHIBIT OFF/ENABLE ON position.

DIP switches are only available on *powerMods* Xg1 to Xg5

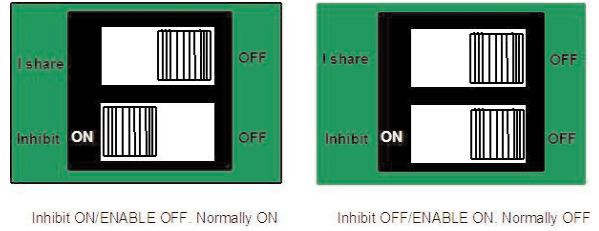

DIP Switch settings on *powerMod*

powerMod Power Good Signal

Each *powerMod* contains an internal comparator which monitors the output voltage and determines whether this voltage is within normal operation limits. When the output voltage is within normal limits, the Power Good signal is activated.

For Xg1-Xg5, an opto-isolated signal is generated and available on J3 pin 7 and J3 pin 8. (opto-transistor ON = Good)

For Xg7, signal is available on J3 Pin 6 and J3 Pin5

For Xg8, V1 signal available on J3 Pin 6 and J3 Pin 5. V2 signal is available on J3 Pin 2 and J3 Pin 1.

Maximum collector current is 2mA

Maximum Collector voltage is 30V

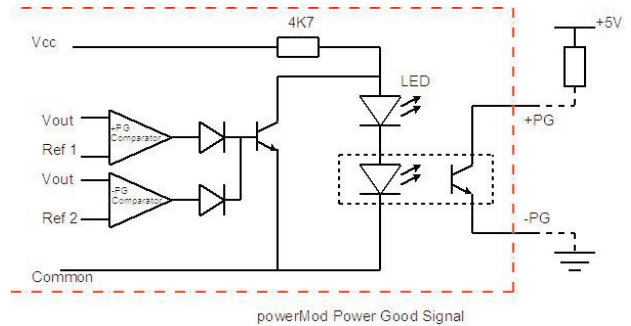

powerMod Power Good Signal

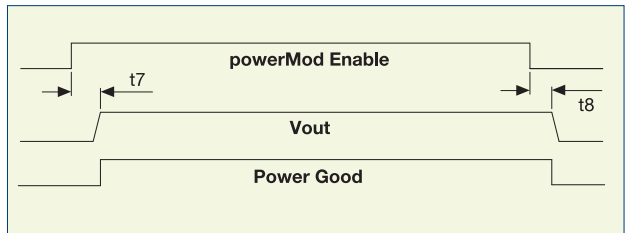

$t7 < 30ms$

$t8 < 30ms$

powerMod LED Indicator

The LED indicator on each *powerMod* module gives a visual indication of the information contained in the Power Good signal above.

Section 9 powerPac operation

The Xgen *powerPac* provides the front end input power to the Xgen *powerMods*. This is available in two package sizes and a number of power ratings. See Sector 11, Power Ratings for more detail.

Bias Voltage

A SELV isolated bias (always on) voltage of 5V @ 250mA (30mA on XCE and XVE models)

is provided on J2 pin 2 relative to J2 pin 1 (common) and may be used for miscellaneous control functions. For medical applications, this bias supply voltage has 4000VAC isolation

Section 10 powerPac (global) signals

AC Fail

AC Mains Fail signal is implemented by an Opto-isolated signal with a maximum sink current of 4mA. During normal operation the transistor is ON. When the input voltage is lost or goes below 80Vac, the opto-transistor is turned OFF at least 5mS before loss of output regulation (at nominal powerMod voltage or below).

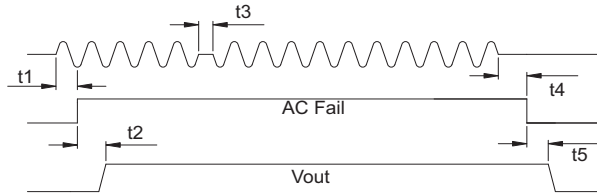

- 80ms < t1 < 100ms
- 80ms < t2 < 150ms
- t3 = 10ms
- t4 > 10ms
- t5 > 5ms

Global Inhibit

A global inhibit function may be implemented via simple contact closure as shown. This function inhibits ALL powerMod outputs except the auxiliary bias voltage. Global inhibit also shuts down the powerPac fans.

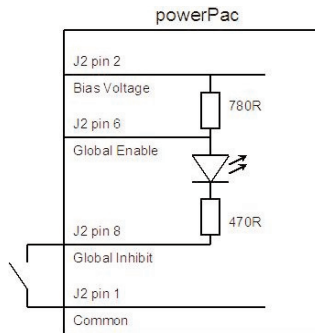

Global Inhibit using the Bias Supply

Global Enable

A global enable function may be implemented via simple contact closure as shown in the diagram .

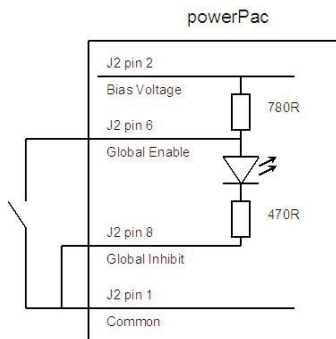

Global Enable using the Bias Supply

Ensure that J2 pin 8 and J2 pin 1 are connected prior to contact closure. This function enables ALL powerMod outputs and the powerPac fans.

Global Inhibit Using an External Signal

A global inhibit function may be implemented using a signal from the system using the diagram shown. This function inhibits ALL powerMod outputs. Global inhibit also shuts down the powerPac fans.

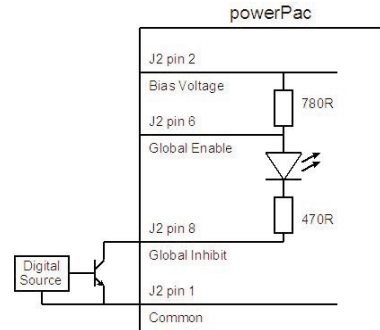

Global Inhibit using System Signal

Global Enable Using an External Signal

A global enable function may be implemented using a signal from the system using the diagram shown. This function enables ALL powerMod outputs.

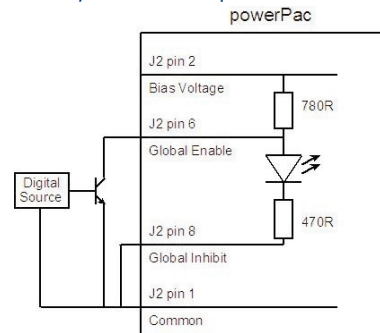

Global Enable using System Signal

Section 11 powerPac options

Temperature Alarm (Option 01)

Open collector signal indicating that excessive temperature has been reached due to fan failure or operation beyond ratings. This signal is activated at least 10ms prior to system shutdown.

Fan Fail (Option 01)

Open collector signal indicating that at least one of the powerPac fans has failed. This does not cause power supply shutdown. The power supply will continue to operate until the 10ms after the Temperature Alarm signal is generated.

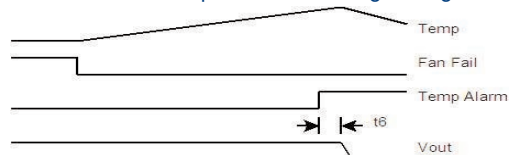

Reverse Fan (Option 02)

The Xgen series is available with reverse air flow direction. This is ideal to expel air from the system and works particularly well with the internal fan cooling built into the overall system.

Reverse Air option is only available on XCA, XCB, XCC, XVA, XVB and XVC, XCE and XVE powerPacs.

XCE reverse fan power rating derates from 1250W at 210VAC to 980W at 100VAC

Section 12 Power Ratings

When specifying an Xgen series power supply in an application it is necessary to ensure that *powerPacs* and *powerMods* are operating within their power output capabilities, taking into account the Temperature Derating and Input Voltage Derating below.

powerMods are designed to provide maximum output power at the nominal output voltages. The maximum permissible output power that may be drawn from any *powerMod* is given in the *powerMod* specification table.

The power rating requirement of the *powerPac* must always be calculated by summing the *powerMod* powers specified in the application. This sum must not exceed the *powerPac* power rating.

powerPac Temperature and Input Voltage Deratings

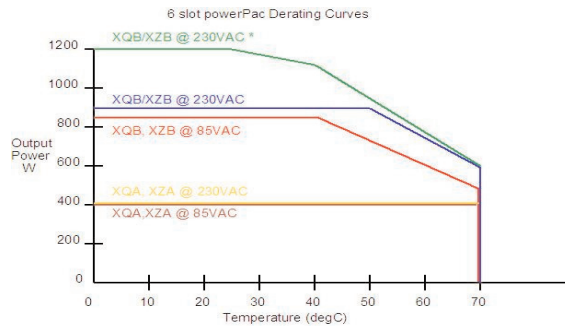
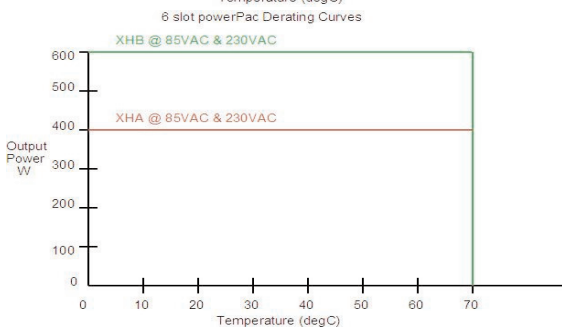
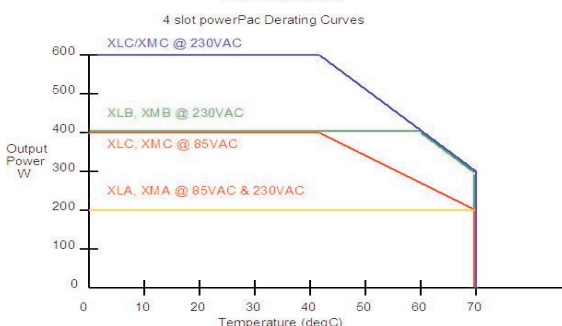
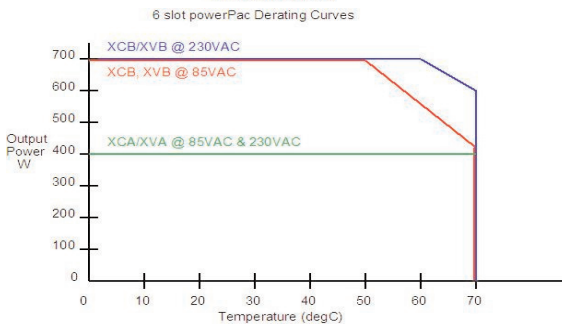
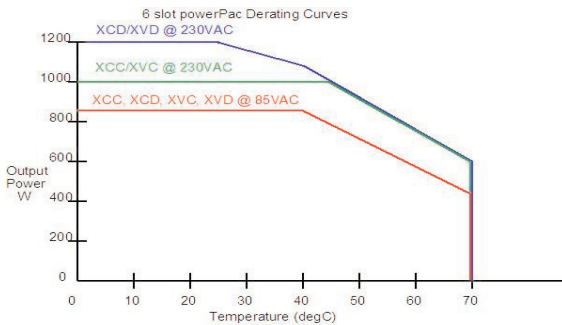

*XQB/XZB 1200W rating. UL approved to 900W

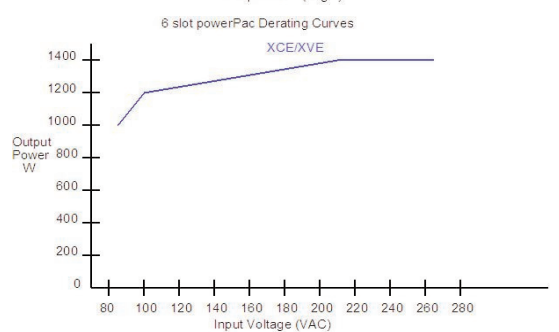
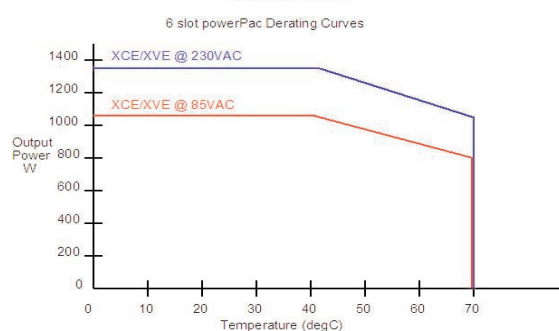
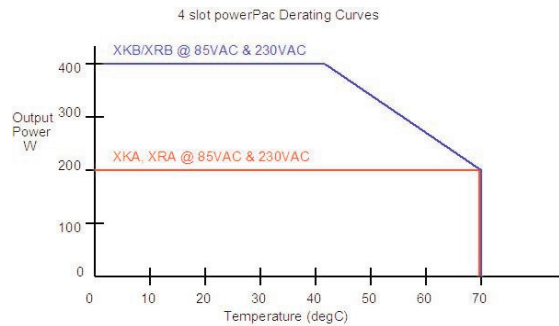

XCE XVE powerPac considerations

1. XCE and XVE can deliver 1450W for a duration of 10s with an 8% duty cycle.
2. When 6 *powerMods* are operated in parallel, the XCE output power must be derated to 1280W
3. At operation above 40°C, it is necessary to apply minimum load to the outputs. See table below for minimum load requirements.

T ambient (°C)	Min Load (W)
40	0
50	100
60	175
70	250

powerMod

All *powerMods* may be used in any *powerPac* slot position. When used in different slot locations, the appropriate temperature derating curve must be observed as set out below. Derating is independent of input voltage.

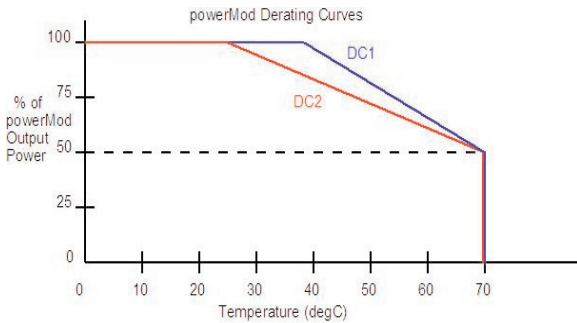

Product	Slot	Xg1	Xg2	Xg3	Xg4	Xg5	Xg7	Xg8
4 Slot	A	DC2	DC2	DC2	DC1	DC1	DC1	DC1
	B	DC2*	DC2*	DC2	DC1	DC1	DC1	DC1
	C	DC2	DC2	DC1	DC1	DC1	DC1	DC1
	D	DC1	DC1	DC1	DC1	DC1	DC1	DC1
6 Slot	A	DC1	DC2	DC1	DC1	DC1	DC1	DC1
	B	DC2*	DC2*	DC1	DC1	DC1	DC2	DC2
	C	DC2	DC1	DC1	DC1	DC1	DC1	DC1
	D	DC1	DC1	DC1	DC1	DC1	DC1	DC1
	E	DC1	DC1	DC1	DC1	DC1	DC1	DC1
	F	DC1	DC1	DC1	DC1	DC1	DC1	DC1

* Device can deliver 95% of rated power at 25degC

Using these derating curves will ensure that the Xgen is populated with powerMods in the best locations in order to optimise system performance.

Section 13 Reliability

The 'bath-tub' curve shows how the failure rate of a power supply develops over time. It is made up of three separate stages.



Immediately after production, some units fail due to defective components or production errors. To ensure that these early failures do not happen while in the possession of the user, Excelsys carries out a burn-in on each unit, designed to ensure that all these early failures are detected at Excelsys. After this period, the power supplies fail very rarely, and the failure rate during this period is fairly constant. The reciprocal of this failure rate is the MTBF (Mean Time Between Failures).

At some time, as the unit approaches its end of life, the first signs of wear appear and failures become more frequent. Generally 'lifetime' is defined as that time where the failure rate increases to five times the statistical rate from the flat portion of the curve.

In summary, the MTBF is a measurement of how many devices fail in a period of time (i.e. a measure of reliability),

before signs of wear set in. On the other hand, the lifetime is the time after which the units fail due to wear appearing.

The MTBF may be calculated mathematically as follows:

MTBF = Total x t / Failure , where
 Total is the total number of power supplies operated simultaneously,
 Failure is the number of failures,
 t is the observation period.

MTBF may be established in two ways, by actual statistics on the hours of operation of a large population of units, or by calculation from a known standard such as Telecordia SR-332 and MIL-HDBK-217 and its revisions.

Determining MTBF by Calculation

MTBF, when calculated in accordance with Telecordia, MIL-HDBK-217 and other reliability tables involves the summation of the failure rates of each individual component at its operating temperature. The failure rate of each component is determined by multiplying a base failure rate for that component by its operating stress level. The result is FPMH, the failure rate per million operating hours for that component.

Then FPMH for an assembly is simply the sum of the individual component FPMH.

Total FPMH = FPMH1 + FPMH2 + +FPMHn

MTBF (hours) = $\frac{1,000,000}{\text{FPMH}}$

In this manner, MTBF can be calculated at any temperature. The Xgen series has the following failure rates at 40°C and full load, based on Telecordia SR-332 standard.

- powerMod 0.98 failures per million hours
- 4slot powerPac 0.92 failures per million hours
- 6slot powerPac 1.15 failures per million hours

The figures for the powerPac excludes fans.

Example:
 What is the MTBF of XLB4400-00
 XLB FPMH = 0.92
 Xg4 FPMH = 0.98
 Total FPMH = 2.88
 MTBF = 347,000 hours at 40°C

MTBF and Temperature

Reliability and MTBF are highly dependent on operating temperature. The figures above are given at 40°C. For each 10°C decrease, the MTBF increases by a factor of approximately 2.5. Conversely, however, for each 10°C increase, the MTBF reduces by a similar factor. Therefore, when comparing manufacturer's quoted MTBF figures, look at the temperature information provided.

Section 14 Safety Approvals

Low Voltage Directive (LVD) 73/23/EEC

The LVD applies to equipment with an AC input voltage of between 50V and 1000V or a DC input voltage between 75V and 1500V. The Xgen series is CE marked to show compliance with the LVD.

The relevant European Standard for Xcite, Xlite, Xhite, Xkite and Xqite models is EN60950 (Information Technology).

The relevant European Standard for Xvite, Xmite, Xrite and Xzite medical models is EN60601-1 (Medical Devices Directive).

With appropriate packaging, the Xgen can also meet the requirements of EN61010-1 for industrial scientific measuring equipment and process control.

The Xcite, Xlite, Xhite, Xkite and Xqite models are designed to comply with the requirements of IEC950, EN60950, UL1950, CSA 22.2 No. 234 and IEC 1010, when correctly installed in a limited access environment.

The Xvite, Xmite, Xrite and Xzite models are designed to comply with the requirements of IEC601-1, EN60601-1, UL2601-1 and CSA601-1, for non-patient connect applications.

powerMods Xg2, Xg3, Xg4 and Xg5 are capable of providing hazardous energy levels (>240 VA). Equipment manufacturers must provide adequate protection to service personnel.

Environmental Parameters

The Xgen series is designed for the following parameters:

Material Group IIIb, Pollution Degree 2

Installation Category 2

Class I

Indoor use (installed, accessible to Service Engineers only).

Altitude: -155 metres to +2000 metres from sea level.

Humidity: 5 to 95% non-condensing.

Operating temperature -20°C to 70°C

Derate to 70°C. See *powerPac* Derating for details.

Approval Limitations

Use in North America

When this product is used on 180 to 253 Volts AC mains with no neutral, connect the two live wires to L (live) and N (neutral) terminals on the input connector.

Standard

Creepage Distances Xcite, Xlite, Xhite, Xkite Xqite models
 Primary mains circuits to earth: 2.5mm spacing
 Primary mains circuits to secondary: 5mm spacing
 Dielectric strength Xcite, Xlite, Xhite, Xkite Xqite models
 Primary mains circuits to chassis: 1500VAC
 Primary mains circuits to secondary: 3000VAC

Medical

Creepage Distances Xvite, Xmite, Xrite, Xzite models
 Primary mains circuits to earth: 4mm spacing
 Primary mains circuits to secondary: 8mm spacing

Dielectric strength Xvite, Xmite, Xrite, Xzite models
 Primary mains circuits to chassis: 1500VAC
 Primary mains circuits to secondary: 4000VAC

The primary to secondary test is not possible with modules fitted to the unit, as damage to the EMI capacitors will occur.

Output Isolation

Outputs are each isolated 500V DC to each other and 500 V DC to chassis.

Section 15 EMC

EMC Directive 89/336/EEC

Component Power Supplies such as the Xgen series are not covered by the EMC directive. It is not possible for any power supply manufacturer to guarantee conformity of the final product to the EMC directive, since performance is critically dependent on the final system configuration.

System compliance with the EMC directive is facilitated by Xgen compliance with several of the requirements as outlined in the following paragraphs. Although the Xgen product series meet these requirements, the CE mark does not cover this area.

EMISSIONS

Power Factor (Harmonic) Correction

The Xgen series incorporates active power factor correction and therefore meets the requirements of EN61000-3-2.

Power factor: 0.98

EN61000-3-3 Flicker & Voltage Fluctuation Limits

Xgen power supplies meet the requirements of the limits on voltage fluctuations and flicker in low voltage supply systems.

EN55022 Class B Conducted Emissions

Under appropriate test conditions, the Xgen series meets the requirements of EN55022 Class B, without the need for external filtering.

IMMUNITY

The Xgen series has been designed to meet, and tested to, the immunity specifications outlined below:

EN61000-4-2 Electrostatic Discharge Immunity

8kV Air discharge applied to Enclosure

6kV Contact with Enclosure

EN61000-4-3 Radiated Electromagnetic Field

10Volts/metre 80MHz to 2.5GHz applied to Enclosure

EN61000-4-4 Fast Transients-Burst Immunity

+/-2kV

EN61000-4-5 Input Surge Immunity

+/-2kV Common Mode 1.2/50 S (Voltage); 8/20uS (Current)

+/- 1kV Differential Mode 1.2/50 S (Voltage) 8/20 S (Current)

EN61000-4-6 Conducted Immunity

10 V/m

150KHz to 80MHz

EN61000-4-11 Voltage Dips

0% 1s Criteria B

40% 100ms Criteria B

70% 10ms Criteria A

Further details on all tests are available from Excelsys.

Guidelines for Optimum EMC Performance

The Xgen series is designed to comply with European Normative limits (EN) for conducted and radiated when correctly installed in a system. See performance levels attained above. However, power supply compliance with these limits is not a guarantee of system compliance. System EMC performance can be impacted by a number and combination items. Design consideration such as PCB layout and tracking, cabling arrangements and orientation of the power supply amongst others all directly contribute to the EMC performance of a system.

Cabling arrangements and PCB tracking layouts are the greatest contributing factor to system EMC performance. It is important that PCB tracks and power cables are arranged to minimise current carrying loops that can radiate, and to minimise loops that could have noise currents induced into them. All cables and PCB tracks should be treated as radiation sources and antennae and every effort should be made to minimise their interaction

- Keep all cable lengths as short as possible.
- Minimise the area of power carrying loops to minimise radiation, by using twisted pairs of power cables with the maximum twist possible..
- Run PCB power tracks back to back.
- Minimise noise current induced in signal carrying lines, by twisted pairs for sense cables with the maximum twist possible.
- Do not combine power and sense cables in the same harness
- Ensure good system grounding. System Earth should be a "starpoint". Input earth of the equipment should be directed to the "starpoint" as soon as possible. The power supply earth should be connected directly to the "starpoint". All other earths should go to the "starpoint"

Section 16 Connectors

The pinout connections and diagrams of the Xgen power and signal connectors are as follows

Output Connector Pinout

Pin	J4 (type A)	J4 (type B)
1	-Vout	-V2
2	+Vout	+V2
3		-V1
4		+V1

Type A, Xg1 -Xg7

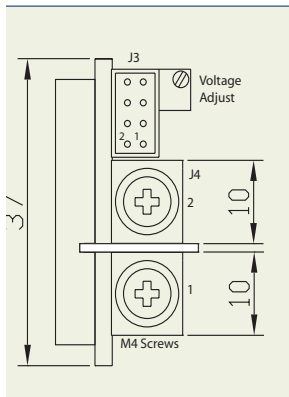

Type B Xg8

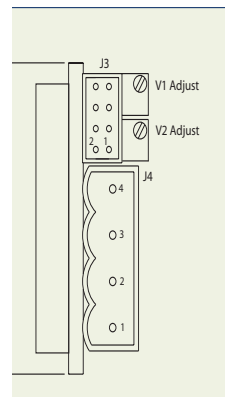

J4 Mating Connectors:
 Type A: M4 Screw Terminals
 Type B: Camden p/n CTB9200/4A

Output Signals Connector Pinout

Pin	J3 (Xg1 to Xg5)	J3 (Xg7)	J3 (Xg8)
1	+Sense	not used	-pg (V2)
2	-Sense	not used	+pg (V2)
3	Vtrim	not used	Inhibit (V2)
4	ltrim	Common	Common (V2)
5	+Inhibit/Enable	-pg	-pg (V1)
6	-Inhibit/Enable	+pg	+pg (V1)
7	+pg	Inhibit	Inhibit (V1)
8	-pg	Common	Common (V1)

J3 *powerMod* Signals Mating Connector:
 Housing: Molex p/n 51110-0850 (Non Locking), 51110-0860 (Locking) or equivalent
 Crimp Terminal: Molex p/n 50394

Input Connections *powerPac*

Input Connector and Signals Pinout J2 *powerPac*

Pin	J1	J2
1	Line	Common
2	Neutral	+5V Bias
3	Earth	not used
4		AC Fail
5		Fan Fail *
6		Global Enable
7		Temp Alarm*
8		Global Inhibit

* Option 01

J1 Mating Connector:
 IEC320 type female plug rated 13A

J2 Signals Mating Connector:
 Housing: Molex p/n 51110-0850 (Non Locking), 51110-0860 (Locking) or equivalent
 Crimp Terminal: Molex p/n 50394

Alternative Input Mains Connector.

Some applications may require a screw terminal input rather than the standard IEC320 connector provided with the Xgen (except XCE and XLD). For such applications, Excelsys can offer the XE1, the IEC to Screw terminal adapter accessory plug. This is a press fit connector that plugs securely into the Xgen *powerPac* and provides the system integrator with screw terminals for mains connection. See photos for correct insertion of XE1.

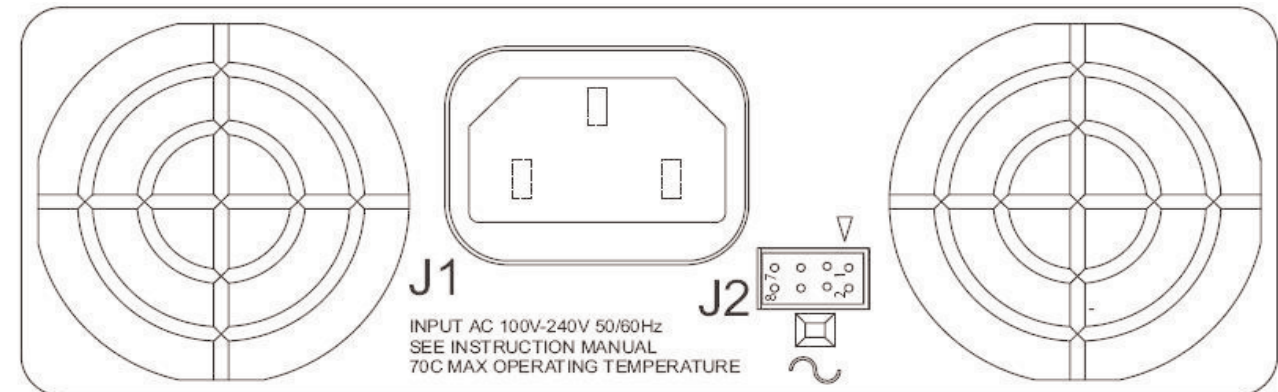

Dimensional drawings

Correct pin positions are indented to assist connection
 Pins are indented to indicate the correct connection

- 1.. Live (L)
2. Earth Centre (Earth)
3. Neutral (N)
4. Screw size M3.

Max Torque to be used on screws is 1.5Nm

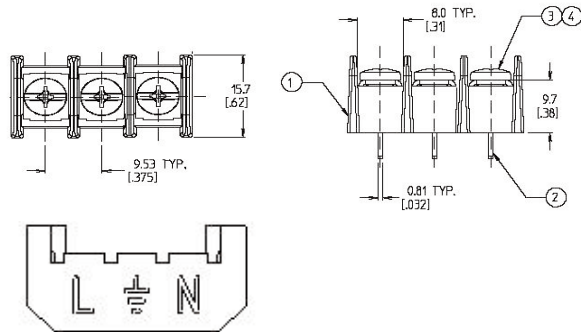
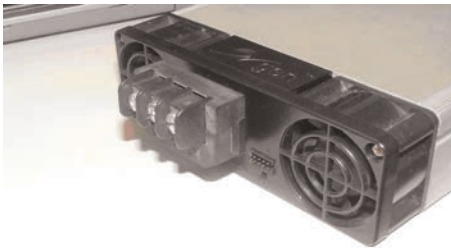

For applications where spade terminal inputs are a required, Excelsys recommend the use of the Schurter IEC Appliance plug 4787. See picture and dimensional drawing. Further information available from <http://www.schurter.com>

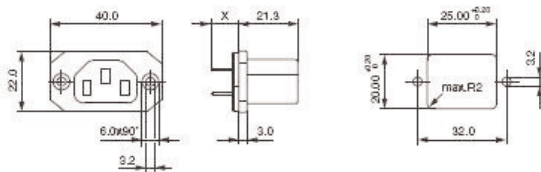

Section 17 Mechanical Drawings

See mechanical drawings for Xgen series overleaf.

Xgen Mounting Options

To ease system integration there are three methods of mounting the Xgen in a system.

1. Base Plate mounting

The unit can be mounted in the system via the mounting holes present on base of Xgen. See mechanical drawings for mounting hole positions. Use M4 mounting screws. Ensure that maximum screw penetration from base does not exceed 6mm.

2. Flexmount system A

Using the side mounting clips accessory shown. The clip can be positioned at the user defined position along the slide rail on the side of the Xgen. The clip is then mounted to the system base plate. Use M4 mounting screws to fix mounting clip to system base. Excelsys part number Z165

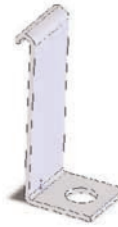

3. Flexmount System 3

Using the slide rail on side of the Xgen, self clenching studs can be placed at a user defined position. PEM part number: FH-M4-X or FH-832-X (X=stud length). See PEM website for further details <http://www.pemnet.com>

Xlite, Xmite, Xkite, Xrite,

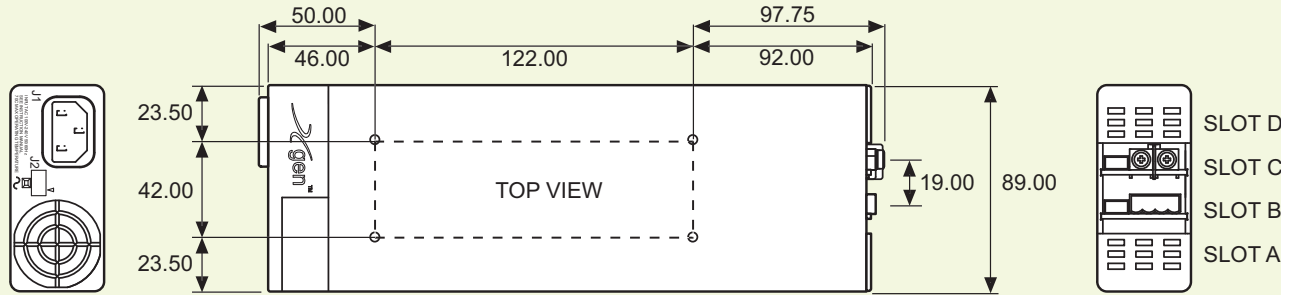
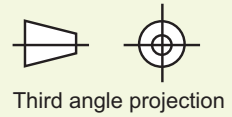

All dimensions in mm.

Mounting Holes

4 M4 threaded holes on Base. Max screw penetration is 6mm from Base.

**Xcite, Xvite, Xqite, Xzite, Xhite
(except XCE and XVE)**

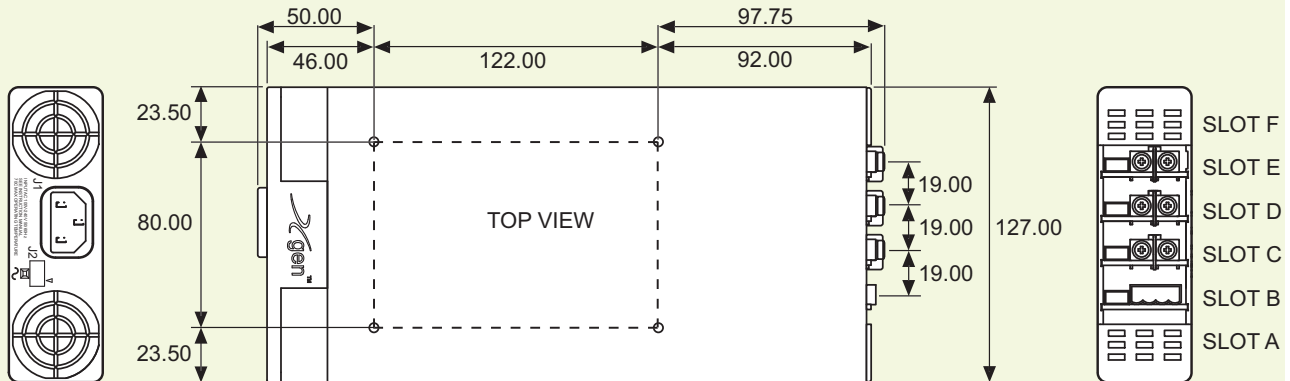
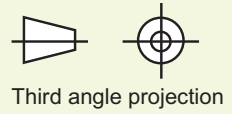

All dimensions in mm.

Mounting Holes

4 M4 threaded holes on Base. Max screw penetration is 6mm from Base.

Fleximount Side Mounting Slots

Use with self-clinching studs type FH-M4-X or FH-832-X (X= stud length) from PEM, or equivalent
Alternatively, use Xgen Side Clamps from Excelsys. Part No. Z165 (drawing 61401)

XCE and XVE

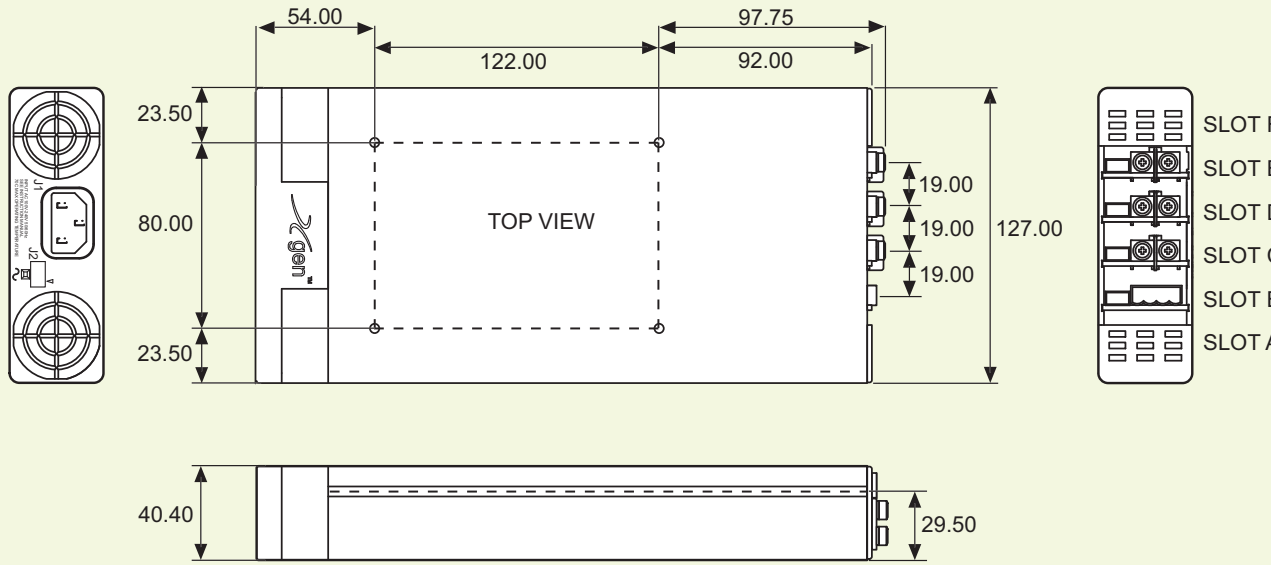
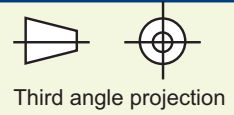

All dimensions in mm.

Mounting Holes

4 M4 threaded holes on Base. Max screw penetration is 6mm from Base.

Fleximount Side Mounting Slots

Use with self-clinching studs type FH-M4-X or FH-832-X (X= stud length) from PEM, or equivalent
 Alternatively, use Xgen Side Clamps from Excelsys. Part No. Z165 (drawing 61401)

Section 18 Configuring Xgen

When configuring your Xgen, it is important to observe the power ratings of individual *powerMods*, *powerPacs* in order to ensure the best performance of the Xgen in the system. Operating ambient temperature around the power supply and Input voltage can impact the performance of a power supply in a system. The examples set out below illustrate the flexibility of the Xgen for many applications, whilst also providing the optimum solution for system designers.

Our Sales and Applications team will be delighted to assist you in defining the best power supply for your application. You can also use the eXcelerate wizard, the online configurator at <http://www.excelsys.com>

Example 1.

	Output 1	Output 2	Output 3	Output 4	Output 5	Max Ambient temp: 25 °C Input volt-
Volts	24V	12V	5V	15V	-15V	
Amps	25A	12A	4A	2A	2A	

age: 90-264VAC
Medically approved (EN60601-1)

1. Select powerMods

Output 1: 24V@25A 3 x Xg4 connected in parallel
Output 2: 12V@12A Xg3
Output 3: 5V@4A Xg7
Output 4: 15V@2A V1 of Xg8, Adjust to 15V
Output 5: -15V@2A V2 of Xg8, Adjust to 15V

2. Calculate the power required

Power = Volt x Current
Output 1: 600W
Output 2: 144W
Output 3: 20W
Output 4: 30W
Output 5: 30W Total: 824W

3. Select powerPac

824W at 90VAC in at 25°C, and carry medical approvals
XVC: 1000W medically approved powerPac (Xvite) delivers 850W at 85VAC.
(Refer to powerPac derating curves Section 12.)

4. Select powerMod slot position

Refer to powerMod derating curve Section 12.
At 25 °C all powerMods can be configured in any slot position.

5. Define part number

All powerMods are within their ratings in all slot positions.
XVC444780

	Output 1	Output 2	Output 3	Output 4	Output 5	Example 2 Max ambient temp: 40 °C
Volts	24V	5V	12V	24V	18V	
Amps	15A	30A	15A	1.5A	1.5A	

Input voltage: 90-264VAC
Low acoustic noise
Standard safety approvals (EN60950)

1. Select powerMods

Output 1: 24V@15A 2 x Xg4 connected in parallel
Output 2: 5V@30A Xg2
Output 3: 12V@15A Xg3
Output 4: 24V@1.5A V1 of Xg8,
Output 5: 18V@1.5A V2 of Xg8, Adjust to 18V

2. Calculate the power required

Power = Volt x Current
Output 1: 360W
Output 2: 150W
Output 3: 180W
Output 4: 36W
Output 5: 29W Total: 756W

3. Select powerPac

756W at 90VAC in at 40°C, and low noise
XQB: 900W low noise powerPac (Xqite) delivers 850W at 85VAC
(Refer to powerPac derating curves Section 12.)

4. Select powerMod slot position

Refer to powerMod derating curve Section 12.
At 40 °C, Xg4 delivers 240W in all slot positions
At 40 °C Xg2 delivers 167W in slot A, 160W Slot B, 200W in Slots C, D, E and F
At 40 °C, Xg3 delivers 240W in all slot positions.
powerMods can be configured in any slot position.
At 40 °C, Xg8 delivers 80W in slot B, 96W in Slots A,C,D,E,F

5. Define part number

	Output 1	Output 2	Output 3	Output 4	Output 5	All powerMods are within their ratings
Volts	24V	12V	3.3V	12V	12V	
Amps	60A	30A	30A	8A	8A	

in all slot positions
XQB234480-00

Example 3

Max ambient temp: 40 °C
Input Voltage: 200-240VAC
Standard Approvals: (EN60950)

1. Select powerMods

Output 1: 24V@60A 6 x Xg4 connected in parallel
Output 2: 12V@30A 2 x Xg3 connected in parallel
Output 3: 3.3V@30A Xg2, Adjust to 3.3V
Output 4: 12V@8A Xg3
Output 5: 12V@8A Xg3

2. Calculate the power required

Power = Volt x Current
Output 1: 1440W
Output 2: 360W
Output 3: 99W
Output 4: 96W
Output 5: 96W Total: 2091W

3. Select powerPac

2091W at 200VAC in at 40°C, and carry standard approvals
XCD: 1200W powerPac (Xvite) delivers 1200W at 200VAC.
(Refer to powerPac derating curves Section 12.)
Requires an XCD and XCC powerPac to achieve 2091W.

4. Select powerMod slot position

Refer to powerMod derating curve Section 12.

At 40°C, Xg4 delivers 240W in all slot positions

At 40°C, Xg3 delivers 240W in all slot positions.

powerMods can be configured in any slot position.

At 40°C Xg2 delivers 167W in slot A, 160W Slot B, 200W in Slots C, D, E and F

5. Define part number

All powerMods are within their ratings in all slot positions.

Divide the power consumption over the two powerPacs ensuring that no powerPac exceed its power rating.

XCC233444 to deliver 3.3V@30A, 12V@30A, 24V@30A

XCC444330 to deliver 24V@30A, 12V@8, 12V@8A

Parallel connect modules over two powerPacs using the same method as outlined in Section 7.

Contact Details

Excelsys Technologies has an international network of distributors and representatives. All contact details can be found at <http://www.excelsys.com>

You can also contact us directly

Europe

Excelsys Technologies Limited

Tel: +353 21 4354716

Fax: +353 21 4354864

email:sales@excelsys.com

27 Eastgate Drive
Eastgate Business Park
Little Island,
Co.Cork, Ireland

North America

Excelsys Technologies

Tel: +1 972 771 4544

Fax: +1 972 421 1805

email:salesusa@excelsys.com

519 Intestate 30, #309
Rockwall
TX 75087, USA

Whilst every effort has been made to ensure the accuracy of the contents of this handbook, Excelsys Technologies Ltd. cannot accept any liability for errors contained herein. Excelsys operates a policy of Continuous Product Improvement, and specifications are subject to change without prior notice.

Rev K

23 June 2010